

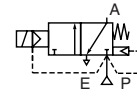

# SOLENOID VALVES

pilot operated, high flow  
floating diaphragms  
3/8 to 1

NC



3/2

Series

NO

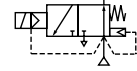

316

## FEATURES

- Brass bodied high flow valves with two floating diaphragms for larger single actuators
- The solenoid valves vent to 0 bar
- Direct lift pilot operators have a resilient soft seating to control the floating diaphragms and to ensure absolute tight shut-off
- The solenoid valves satisfy all relevant EC Directives

## GENERAL

Differential pressure 0,7 - 10 bar [1 bar = 100kPa]

Maximum viscosity 65cST (mm<sup>2</sup>/s)

Response times 40 - 120 ms

fluids (*)	temperature range (TS)	seal material (*)
air, inert gas, water <sup>(1)</sup>	-20 to +80°C (**)	NBR (nitrile)

<sup>(1)</sup> Low power executions air only

<sup>(\*\*)</sup> Maximum ambient temperature for low power executions is 60°C

## MATERIALS IN CONTACT WITH FLUID

(\*) Ensure that the compatibility of the fluids in contact with the materials is verified

	Basic Power	Low Power
Body	Brass	Brass
Core tube	Stainless steel	Stainless steel
Core and plugnut	Stainless steel	Stainless steel
Core spring	Stainless steel	Stainless steel
Sealings & discs	NBR	NBR
Disc holder	CA	-
Diaphragms	NBR	NBR
Cartridge	-	Welded, packless AISI 430 SS
Seat	Brass	Brass
Seat insert	CA	CA
Shading coil	Copper	-
Rider ring	-	PTFE

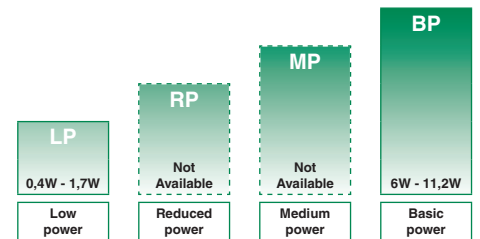
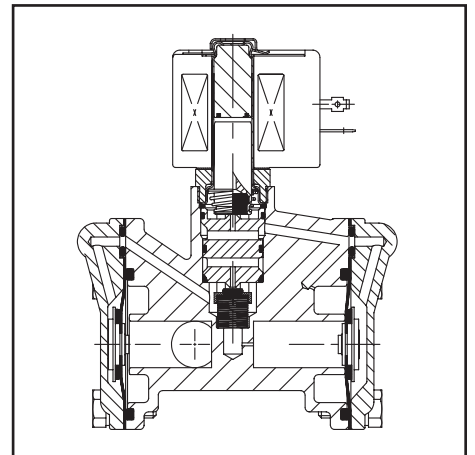

POWER LEVELS - cold electrical holding values (watt)

## SPECIFICATIONS

pipe size	orifice size	flow coefficient kv		operating pressure differential (bar)			power level	prefix optional solenoids					basic catalogue number	
				min. <sup>(3)</sup>	max. (PS)			NEMA 7 & 9	ATEX / IECEx			IP65	brass	stainless steel
					air (*)	~			=	Ex d	Ex e mb			
NPT	(mm)	(m <sup>3</sup> /h)	(l/min)				~/=	EF	NF	EM	PV	SC		
<b>NC - Normally closed</b>														
3/8	16,0	2,0	41,6	0,7	8,5	8,5	BP	●	●	●	●	●	B316A054	-
1/2	16,0	2,8	56,6	0,7	8,5	8,5	BP	●	●	●	●	●	❖316A064	-
3/4	18,0	4,2	78,3	0,7	8,5	8,5	BP	●	●	●	●	●	B316B074	-
3/4	17,0	4,2	78,3	0,7	10,0	10,0	LP	○	●	●	○	●	B316B374	-
1	25,0	11,3	184,9	0,7	8,5	8,5	BP	●	●	●	●	●	❖316E034	-
1	25,0	11,3	184,9	0,7	10,0	10,0	LP	○	●	●	○	●	❖316A334	-
<b>NO - Normally open</b>														
3/8	16,0	2,0	41,6	0,7	8,5	8,5	BP	●	●	●	●	●	B316A056	-
1/2	16,0	2,8	56,6	0,7	8,5	8,5	BP	●	●	●	●	●	❖316A066	-
3/4	18,0	4,2	78,3	0,7	8,5	8,5	BP	●	●	●	●	●	B316B076	-
1	25,0	11,3	184,9	0,7	8,5	8,5	BP	●	●	●	●	●	B316E036	-

❖ Select B for NPT ANSI 1.20.3

Select E for ISO Rp (7/1)

● Available feature

○ Available feature in DC only

- Not available

<sup>(1)</sup> Differential pressure (PS) 17 bar available on request

## PREFIX TABLE

prefix							description	power level			
1	2	3	4	5	6	7		LP	RP	MP	BP
E	F						Explosionproof - NEMA 7, 9 - Zinc plated steel conduit	○	-	-	●
E	V						Explosionproof - NEMA 7, 9 - 316 SS conduit	○	-	-	●
E	M						Waterproof IP66/67 - Metal enclosure (EN/IEC 60079-7,-18 and -31)*	●	-	-	●
		E	T				Threaded conduit/hole (M20 x 1,5)	●	-	-	●
N	F						Flameproof - Aluminium (EN/IEC 60079-1, 60079-31)*	●	-	-	●
P	V						Encapsulated epoxy moulded (EN/IEC 60079-18)*	○	-	-	●
S	C						Solenoid with spade plug connector (EN/IEC 60730)	●	-	-	●
W	P						Waterproof IP67 - Metal enclosure	●	-	-	●
W	S						Waterproof IP67 - 316 SS enclosure	●	-	-	●
W	S	E	M				Waterproof IP66/67 - 316 SS enclosure (EN/IEC 60079-7,-18 and -31)*	●	-	-	●
W	S	N	F				Flameproof - 316L SS (EN/IEC 60079-1, 60079-31)*	●	-	-	●
							Threaded conduit (1/2" NPT)	●	-	-	●
					H	C	Class H - Battery charging circuit	-	-	-	●
					H	T	Class H - High temperature	-	-	-	●
						X	Other special constructions	●	-	-	●

## SUFFIX TABLE

suffix					description	power level			
1	2	3	4	5		LP	RP	MP	BP
E					EPDM (ethylene-propylene)	●	-	-	●
J					CR (chloroprene)	●	-	-	●
N					Oxygen service (CR (chloroprene))	●	-	-	●
N	V				FPM (fluoroelastomer) and parts cleaned for oxygen service	●	-	-	●
V					FPM (fluoroelastomer)	●	-	-	●
	C	O			Epoxy coating on all external surfaces	●	-	-	●
	M	B			Mounting bracket	●	-	-	●
		P			Dry gas, non-lubricated air construction	-	-	-	●
		Q			Long life, quiet operation construction	-	-	-	○
			M	O	Push type manual operator	●	-	-	●

- Available feature
- Available feature in DC only
- Not available
- \* ATEX/IECEx valves using these solenoids are approved according to EN 13463-1 (non electrical)

## PRODUCT SELECTION GUIDE

### STEP 1

Select basic catalogue number, including pipe thread identification letter. Refer to the specifications table on page 1.

**Example: E316E034**

### STEP 2

Select prefix (combination). Refer to the specifications table on page 1 and the prefix table on page 2, respect the indicated power level.

**Example: PV**

### STEP 3

Select suffix (combination) if required. Refer to the suffix table on page 2, respect the indicated power level.

**Example: E**

### STEP 4

Select voltage. Refer to standard voltages on page 3.

**Example: 24V / 50Hz**

### STEP 5

Final catalogue / ordering number.

**Example:**

**PV E316E034 E 24V / 50 Hz**

## OPTIONS & ACCESSORIES

catalogue number	spare parts kit no. <sup>(1)</sup>		mounting bracket no.
	~	=	
SC B 316A054	C314491	C314540	038713-000
SC ❖ 316A064	C314491	C314540	038713-000
SC B 316B074	C314491	C314540	038713-000
SC ❖ 316E034	C302661	C302681	-
SC B 316A056	C314492	C314494	038713-000
SC ❖ 316A066	C314492	C314494	038713-000
SC B 316B076	C314492	C314494	038713-000
SC B 316E036	C302671	C302691	-
SC ❖ 316A334	C316850	C316850	-
SC B 316B374	C323082	C323082	038713-000

- <sup>(1)</sup> Standard prefixes/suffixes are also applicable to kits  
❖ Select **B** for NPT ANSI 1.20.3 or select **E** for ISO Rp (7/1)

## ORDERING EXAMPLES:

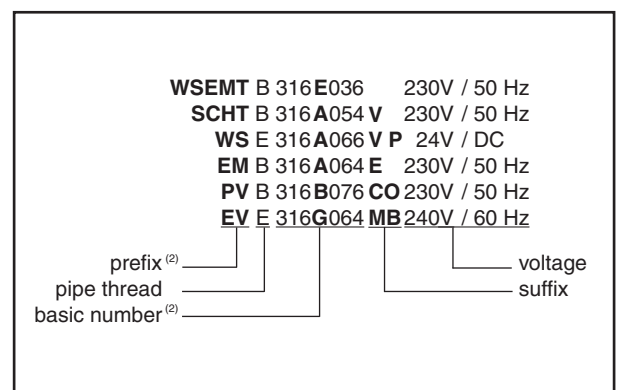

## ORDERING EXAMPLES KITS:

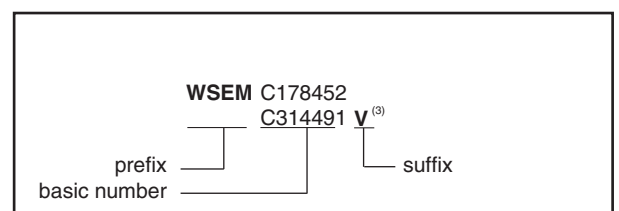

- <sup>(2)</sup> Prefix EF and EV should always be used in conjunction with change letter G in the basic number  
<sup>(3)</sup> Basic kit number applies to SC coil construction

**EXPLANATION OF TEMPERATURE RANGES OF SOLENOID VALVES**

Valve temperature range The valve temperature range (TS) is determined by the selected seal material, the temperature range for proper operation of the valve and sometimes by the fluid (e.g. steam)

Operator ambient temperature range The operator ambient temperature range is determined by the selected power level and the safety code

Total temperature range The temperature range of the complete solenoid valve is determined by the limitations of both temperature ranges above

**ELECTRICAL CHARACTERISTICS**

**Coil insulation class** F

**Connector** Spade plug

**Connector specification** ISO 4400 (cable Ø 6-10 mm)

**Electrical safety** IEC 335

**Standard voltages** DC (=) 24V - 48V; Allowable voltage variation +10%, -15%  
AC (~) 24V - 48V - 115V - 230V/50Hz; Other voltages and 60Hz are available on request

prefix option	power ratings				operator amb. temp. range (TS) (C°) <sup>(1)</sup>	safety code	electrical enclosure protection (EN 60529)	replacement coil / kit		type <sup>(2)</sup>
	inrush	holding	hot/cold	=				~	=	
	(VA)	(VA)   (W)	(W)	(W)				230 V/50 Hz	24V/DC	
<b>Basic power (BP)</b>										
SC	34,0	15,6	6,0	7,0/9,7	-40 to +75	EN 60730	IP65, moulded	400325-117	400325-142	01/02
WP/WS	34,0	15,6	6,0	7,0/9,7	-40 to +75	EN 60730	IP67, steel/SS	400305-117	400305-142	05/06
NF/WSNF	55,0	23,0	10,5	-	-60 to +25/40/60	II2G Ex d IIC Gb T6/T5/T4, II2D Ex tb IIIC Db	IP66/67, alu./SS	400405-117	-	03/04
NF/WSNF	-	-	-	9,0/11,2	-60 to +40/60/75	II2G Ex d IIC Gb T6/T5/T4, II2D Ex tb IIIC Db	IP66/67, alu./SS	-	400405-142	03/04
EM/WSEM	55,0	23,0	10,5	9,0/11,2	-40 to +40	II2G Ex e mb IIC Gb T3, II2D Ex tb IIIC Db	IP66/67, steel/SS	400909-117	400913-142	05/06
PV	55,0	23,0	10,5	9,0/11,2	-40 to +65	II2G Ex mb IIC Gb T3(-)/T4(=), II2D Ex mb IIIC Db	IP65, moulded	- <sup>(3)</sup>	- <sup>(3)</sup>	07/08
EF	30,0	16,0	6,1	7,0/10,6	-40 to +52/40	NEMA type 7 and 9	NEMA 4X	238214-057D	238314-006D	09/10
<b>Low power (LP)</b>										
SC	1,5	1,5	1,5	1,7/1,7	-40 to +60	EN 60730	IP65, moulded	400925-097	400925-042	11
WP/WS	1,5	1,5	1,5	1,7/1,7	-40 to +60	EN 60730	IP67, steel/SS	400926-097	400926-042	12
NF/WSNF	1,85	1,85	1,85	1,5/1,8	-60 to +55	II2G Ex d IIC Gb T6, II2D Ex tb IIIC Db	IP66/67, alu./SS	- <sup>(4)</sup>	400914-542	-
EM/WSEM	1,5	1,5	1,5	1,7/1,7	-40 to +40/55	II2G Ex e mb IIC Gb T6/T5, II2D Ex tb IIIC Db	IP66/67, steel/SS	400926-097	400926-042	12
PV	-	-	-	1,7/1,7	-40 to +60	II2G Ex mb IIC Gb T6, II2D Ex mb IIIC Db	IP67, moulded	-	- <sup>(3)</sup>	13
EF	-	-	-	1,4/1,4	-40 to +60	NEMA type 7 and 9	NEMA 4X	-	238714-902D	14

<sup>(1)</sup> Temperature range can be limited by sealings  
<sup>(3)</sup> Multiple coil-kits available under ATEX, contact us

<sup>(2)</sup> Refer to the dimensional drawings on page 4 and 5  
<sup>(4)</sup> AC (~) limited to 127V/50/60Hz or 125V/DC

- Not available

**MOUNTING BRACKET**

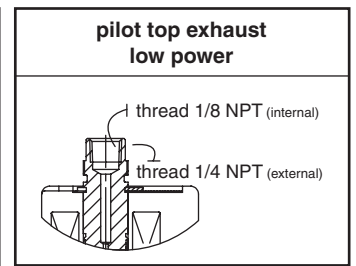
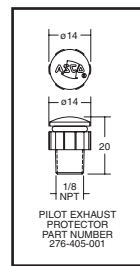
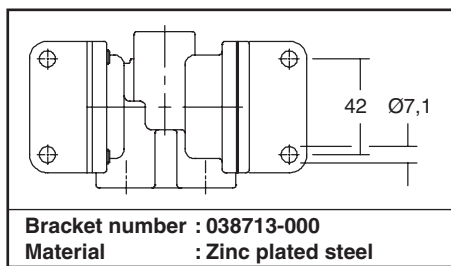

**ADDITIONAL OPTIONS**

- Other pipe threads are available on request
- Ex mb (prefix "PV") execution can be supplied in various cable lengths
- Compliance with "UL", "CSA" and other local approvals available on request
- 1/2" NPT (prefix "T") and M20 x 1,5 (prefix "ET") conduits (aluminium or 316 SS) available for steel solenoid housing
- Special moulded-in solid state components for peak voltage suppression and/or rectification (four diode bridge)

**INSTALLATION**

- Multi language installation/maintenance instructions are included with each valve
- The solenoid valves can be mounted in any position without affecting operation
- Threaded pipe connection identifier is B = NPT (ANSI 1.20.3); E = ISO-7
- Important: a minimum operating pressure differential must be maintained between the pressure and exhaust ports. Supply and exhaust piping must be full area and unrestricted
- Declarations of conformity are available on request
- Ex e mb (prefix "EM") execution: solenoid enclosure has a cable gland with integral strain relief for cables with an o.d. from 7 to 12 mm and is provided with an internal and external connection facility for an earthing or bonding conductor

## DIMENSIONS (mm), WEIGHT (kg)



**TYPE 01**  
Epoxy moulded  
SC: IEC 335 / ISO 4400

316A054 / A064 / A056 / A066

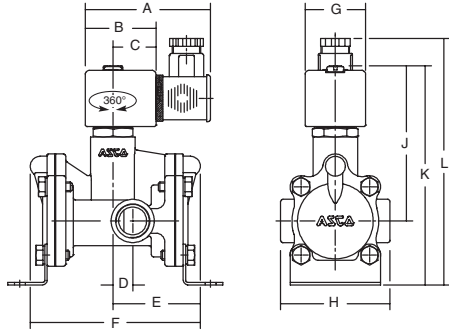

**TYPE 02**  
Epoxy moulded  
SC: IEC 335 / ISO 4400

316B074 / E034 / E076 / E036

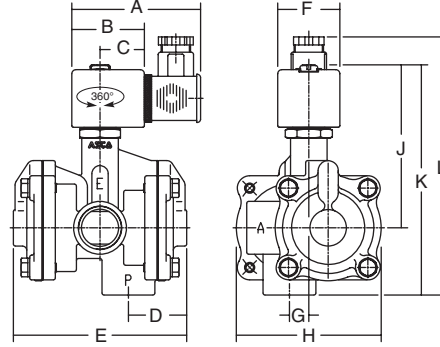

**TYPE 03**  
Aluminium, epoxy coated / AISI 316L SS  
NF / WSNF: EN/IEC 60079-1, 60079-31

316A054 / A064 / A056 / A066

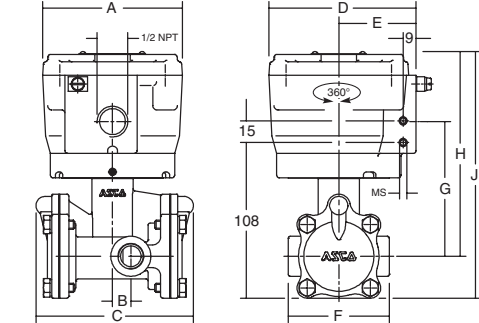

**TYPE 04**  
Aluminium, epoxy coated / AISI 316L SS  
NF / WSNF: EN/IEC 60079-1, 60079-31

316B074 / E034 / E076 / E036

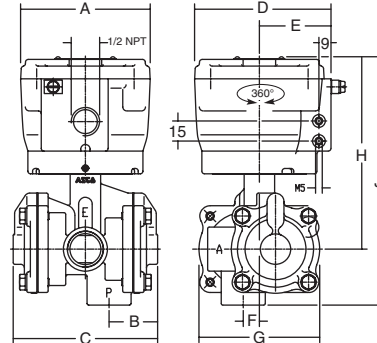

**TYPE 05**  
Metal, epoxy coated / AISI 316 SS  
WP / WS: IEC 335  
EM / WSEM: EN/IEC 60079-7+18+31

316A054 / A064 / A056 / A066

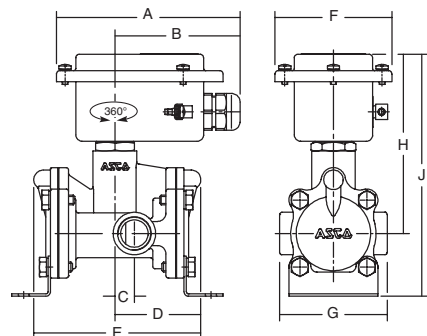

**TYPE 06**  
Metal, epoxy coated / AISI 316 SS  
WP / WS: IEC 335  
EM / WSEM: EN/IEC 60079-7+18+31

316B074 / E034 / E076 / E036

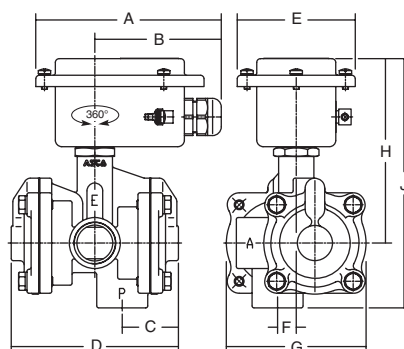

### DIMENSIONS (mm), WEIGHT (kg)



**TYPE 07**  
Epoxy encapsulated  
PV: EEN/IEC 60079-18

316A054 / A064 / A056 / A066

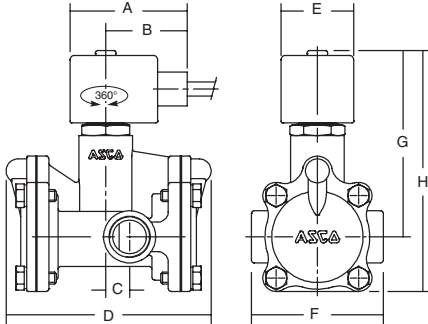

**TYPE 08**  
Epoxy encapsulated  
PV: EN/IEC 60079-18

316B074 / E034 / E076 / E036

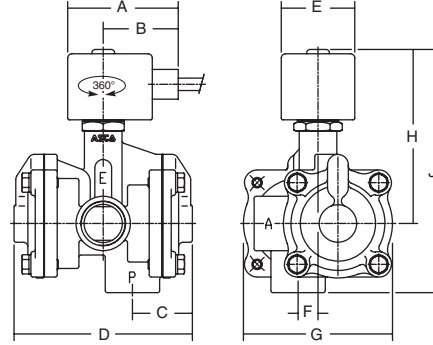

**TYPE 09**  
Epoxy encapsulated  
EF: ICS-6 ANSI / NEMA Type 7 and 9  
NOTE: applicable to solenoid only

316G054 / G064 / G056 / G066

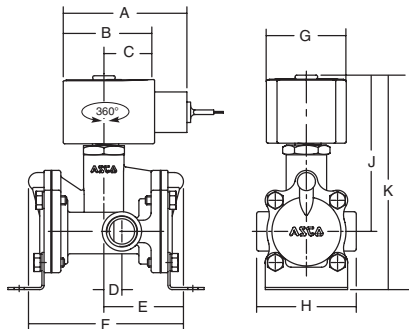

**TYPE 10**  
Epoxy encapsulated  
EF: ICS-6 ANSI / NEMA Type 7 and 9  
NOTE: applicable to solenoid only

316G074 / G034 / G076 / G036

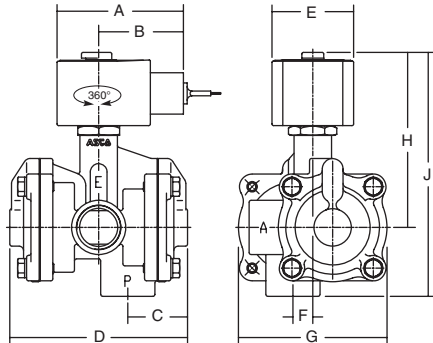

**TYPE 11**  
Epoxy moulded  
SC: IEC 335 / ISO 4400

316B334 / B374

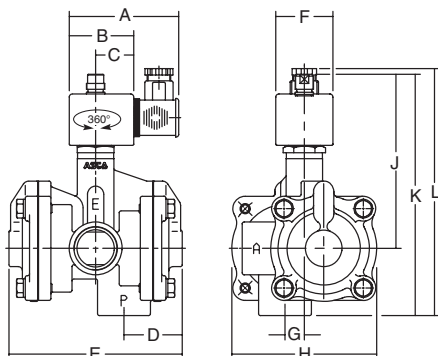

**TYPE 12**  
Metal, epoxy coated / AISI 316 SS  
WP / WS: IEC 335  
EM / WSEM: EN/IEC 60079-7+18+31

316B334 / B374

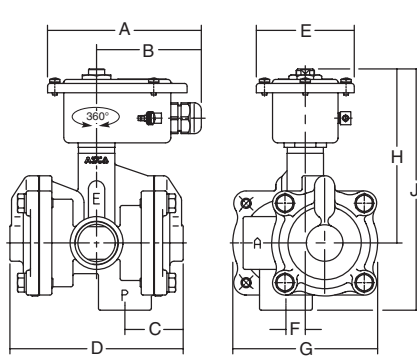

### DIMENSIONS (mm), WEIGHT (kg)



**TYPE 13**  
Epoxy encapsulated  
PV: EN/IEC 60079-18

316B334 / B374

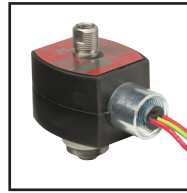
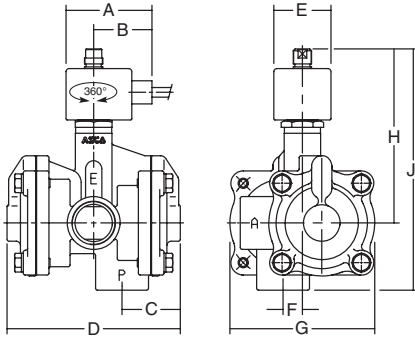

**TYPE 14**  
Epoxy encapsulated  
EF: ICS-6 ANSI / NEMA Type 7 and 9  
NOTE: applicable to solenoid only

316G334 / G374

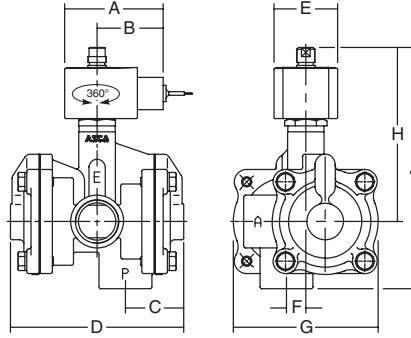

### SECTIONAL DRAWING

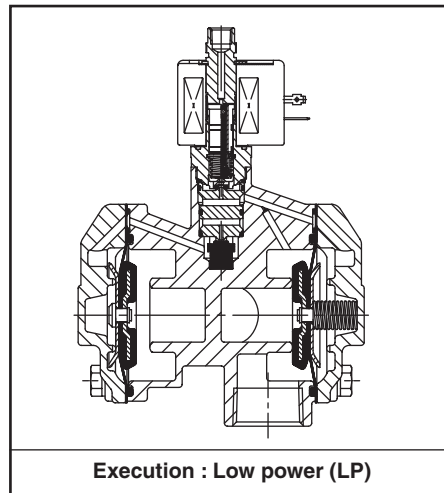

type	prefix option	power level	A	B	C	D	E	F	G	H	J	K	L	weight
01	SC	BP	75	45	28	13	56	109	39	70	100	130	140	4,40 kg
02	SC	BP	75	45	28	36	108	39	12	90	101	143	161	4,40 kg
03	NF, WSNF	BP	97	13	109	102	58	70	93	112	171	13	35	5,50 kg
04	NF, WSNF	BP	97	36	108	102	54	12	90	144	186	-	-	5,50 kg
05	WP, WS, EM, WSEM	BP	120	82	13	56	109	77	70	117	158	-	-	4,45 kg
06	WP, WS, EM, WSEM	BP	120	82	36	108	76	12	90	119	161	-	-	4,45 kg
07	PV	BP	67	45	36	109	39	70	99	128	-	-	-	4,40 kg
08	PV	BP	67	45	36	108	45	12	90	105	147	-	-	4,40 kg
09	EF	BP	70	44	22	13	56	109	43	70	180	130	-	4,40 kg
10	EF	BP	70	48	36	108	43	12	90	106	148	-	-	4,40 kg
11	SC, ZN	LP	85	50	30	45	135	45	15	113	135	188	192	4,40 kg
12	WP, WS, EM, WSEM	LP	120	82	45	135	77	15	113	135	188	-	-	4,45 kg
13	PV	LP	67	45	45	135	45	15	113	135	188	-	-	4,40 kg
14	EF	LP	77	52	45	135	50	15	113	135	188	-	-	4,45 kg