

### FEATURES

- Ruggedly built valve, particularly recommended for use with steam, superheated water, corrosive fluids
- High-performance, maintenance-free stuffing box, resistant to thermal shock
- Mixer function (two pressure inlets at 1 or 3, one outlet at 2) or distributor function (one pressure inlet at 2, two outlets at 1 and 3)
- Vacuum operation up to  $10^{-2}$  mbar
- Allowable backpressure: up to 40 bar
- Optical position indicator as standard
- Autoclavable valve for use at high ambient temperatures (up to 180°C)
- The valves satisfy Pressure Equipment Directive 97/23/EC, category 1 (DN > 32) or article 3.3 (DN ≤ 32)

### GENERAL

Differential pressure	0 to 40 bar [1 bar = 100 kPa]
Maximum allowable pressure	40 bar (within the specified limits, see diagram I)
Ambient temperature range	-25°C to +180°C
Maximum viscosity	5000 cSt (mm <sup>2</sup> /s)
Pilot fluid	Air
Max. pilot pressure	10 bar
Min. pilot pressure	See below

fluids (*)	temperature range	disc seal (*)
DN 15-20-25: air and gas groups 1 & 2 DN 32-40-50: air and gas group 2 all DN: superheated water, liquids groups 1 & 2 and steam	-10°C to +250°C	bronze PTFE

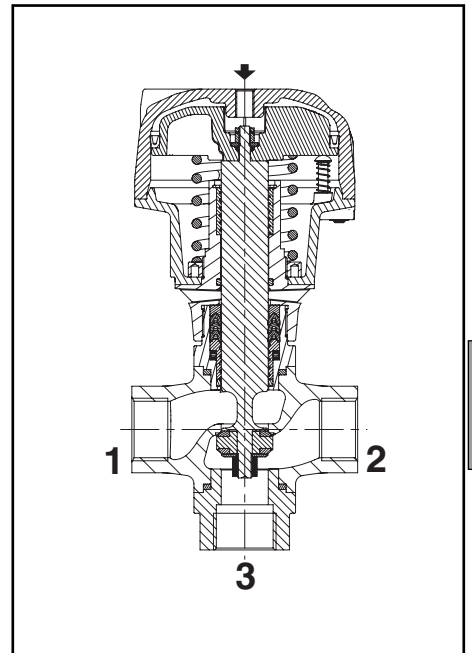
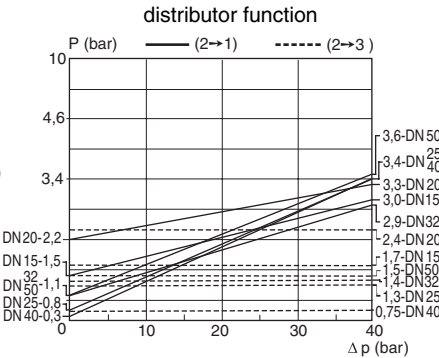
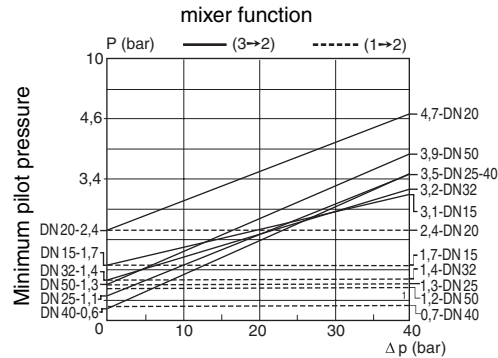

### MATERIALS IN CONTACT WITH FLUID

(\*) Ensure that the compatibility of the fluids in contact with the materials is verified

Valve body and plug	Stainless steel
Stuffing box housing	Stainless steel
Stem, disc	Stainless steel
Stuffing box packing	PTFE chevrons
Disc seal	Bronze PTFE
Valve body seal	Graphite
OTHER MATERIALS	
Operator	Aluminium, nickel plated

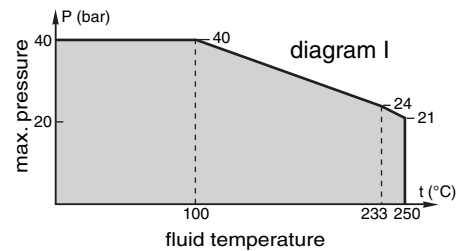

### SPECIFICATIONS

piping (ISO 6708)	pipe size DN	flow coefficient Kv								pilot pressure (bar)		operating pressure differential (bar)	operator diameter (mm)	catalogue number
		mixer				distributor				min.	max.			
		3→2 (m <sup>3</sup> /h)	1→2 (l/min)	1→2 (m <sup>3</sup> /h)	3→2 (l/min)	2→3 (m <sup>3</sup> /h)	2→1 (l/min)	2→1 (m <sup>3</sup> /h)	3→2 (l/min)					
<b>U - Universal</b>														
1/2	15	3,3	54	4,4	73	3,5	59	4,6	78	*	10	40	80	E398A001
3/4	20	8,0	133	7,4	123	8,1	136	7,7	129	*	10	40	100	E398A002
1	25	11,4	190	11,6	194	12,1	203	11,9	199	*	10	40	100	E398A003
1 1/4	32	18,9	316	16,6	278	17,9	299	16,6	278	*	10	40	150	E398A004
1 1/2	40	27	450	27	450	27	450	27	450	*	10	40	150	E398A005
2	50	51	850	51	850	51	850	51	850	*	10	40	200	E398A006

\* Minimum pilot pressure varies with differential pressure. See piloting charts above.

### OPTIONS AND ACCESSORIES

- Metal-to-metal sealing disc
- ATEX 94/9/EC versions for potentially explosive atmospheres, categories 2 GD and 3 GD
- Valve seat leakage class VI as defined by FCI 70-2, contact us
- Other pipe connections are available on request

### INSTALLATION

- The valves can be mounted in any position without affecting operation
- Compatible with ASTM 1, 2 and 3 oils
- Pipe connections (G\*) have standard thread according to ISO 228/1 and ISO 7/1
- Installation/maintenance instructions are included with each valve

### SPARE PARTS KITS

catalogue number	spare parts kit no.		
	piston seal	actuator spring	stem, disc, seals
E398A001	C140233	C140299	C140323
E398A002	C140234	C140301	C140324
E398A003	C140234	C140303	C140225
E398A004	C140235	C140305	C140326
E398A005	C140235	C140307	C140327
E398A006	C140298	C140309	C140328

### ORDERING EXAMPLES / VALVES:

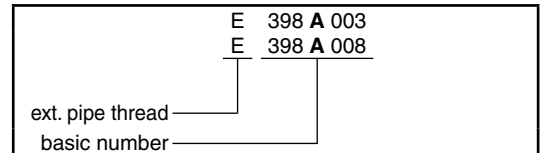

### ORDERING EXAMPLES / KITS:

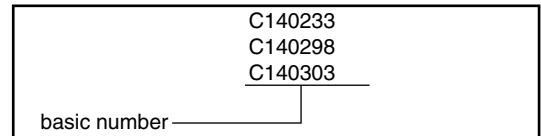

### DIMENSIONS (mm), WEIGHT (kg)



#### TYPE 01-02-03-04 Prefix "E"

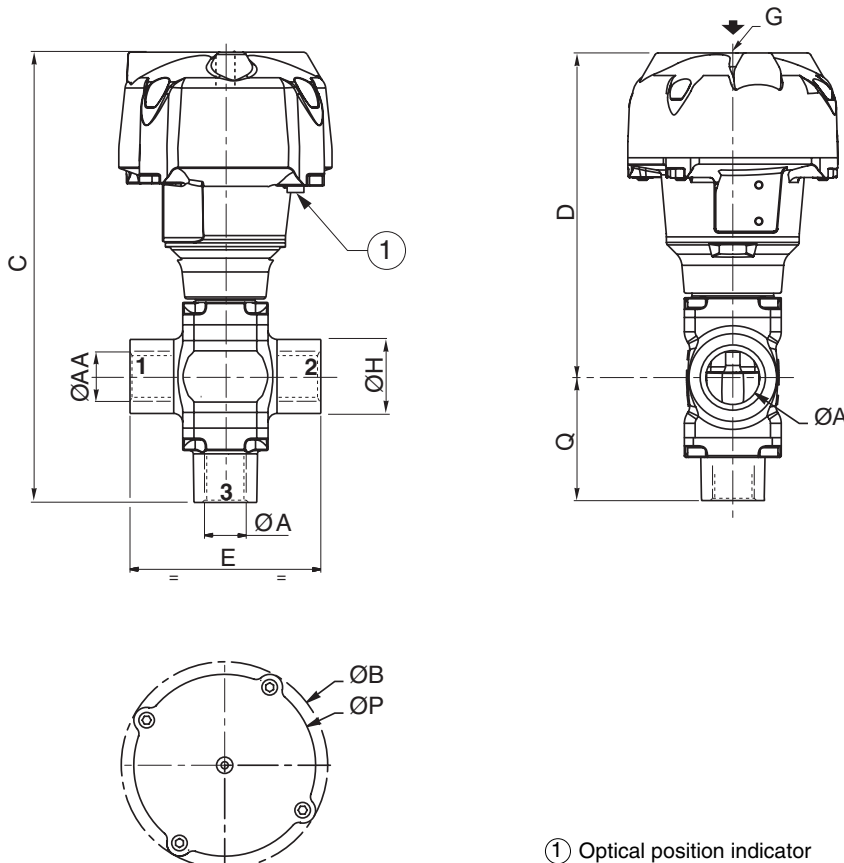

① Optical position indicator

type	DN	operator diameter	ØA	ØAA	ØB	C	D	E	G	ØH	ØP	Q	weight
01	15	80	15	1/2"	110	203,1	151,6	85	1/8	33	95	51,5	1,88
02	20	100	20	3/4"	132,5	229,2	170,9	110	1/8	40	117	58,3	3,52
	25	100	25	1"	132,5	244,9	180,9	120	1/8	46	117	64	4,24
03	32	150	32	1"1/4	191	318,2	237,2	145	1/4	57	172,5	81	9,38
	40	150	40	1"1/2	191	361,7	259,2	150	1/4	65	172,5	102,5	11,9
04	50	200	50	2"	247	436	328,5	190	1/4	75	230	107,5	23,66