

FEATURES

- Ruggedly built valve, particularly recommended for use with steam, superheated water, corrosive fluids
- High-performance, maintenance-free stuffing box, resistant to thermal shock
- Mixer function (two pressure inlets at 1 or 3, one outlet at 2) or distributor function (one pressure inlet at 2, two outlets at 1 and 3)
- Vacuum operation up to 10^{-2} mbar
- Allowable backpressure: up to 40 bar
- Optical position indicator as standard
- Autoclavable valve for use at high ambient temperatures (up to 180°C)
- The valves satisfy Pressure Equipment Directive 97/23/EC, category 1 (DN > 32) or article 3.3 (DN ≤ 32)

GENERAL

Differential pressure	0 to 40 bar [1 bar = 100 kPa]
Maximum allowable pressure	40 bar (within the specified limits, see diagram I)
Ambient temperature range	-25°C to +180°C
Maximum viscosity	5000 cSt (mm ² /s)
Pilot fluid	Air
Max. pilot pressure	10 bar
Min. pilot pressure	See below



fluids (*)	temperature range	disc seal (*)
DN 15-20-25: air and gas groups 1 & 2 DN 32-40-50: air and gas group 2 all DN: superheated water, liquids groups 1 & 2 and steam	- 10°C to + 250°C	bronze PTFE

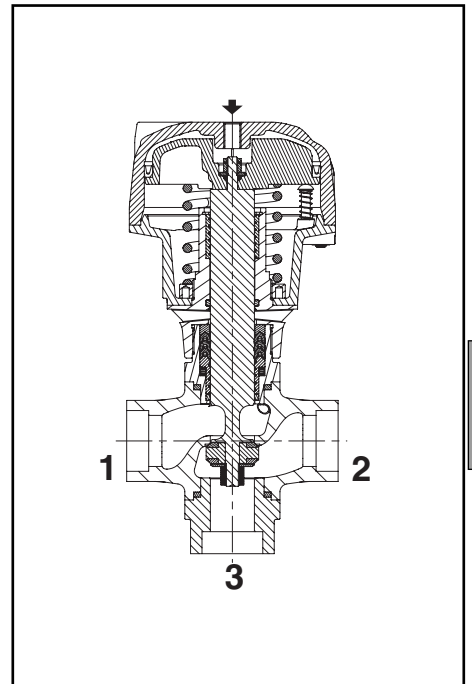
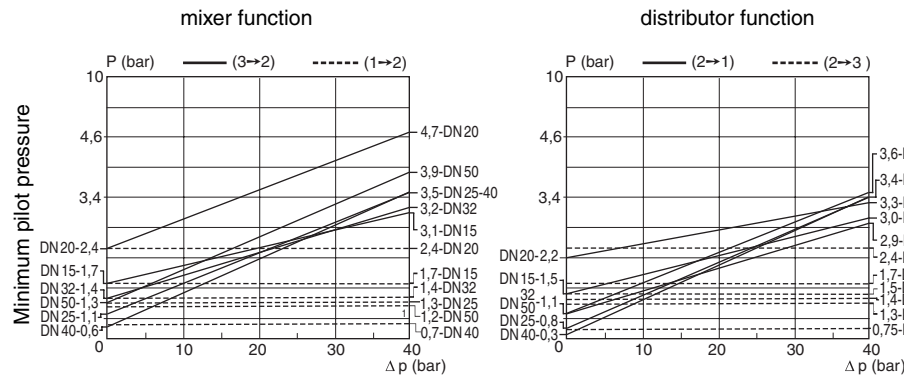

CONSTRUCTION

Socket welding ends EN 12760

MATERIALS IN CONTACT WITH FLUID

(*) Ensure that the compatibility of the fluids in contact with the materials is verified

Valve body and plug	Stainless steel
Stuffing box housing	Stainless steel
Stem, disc	Stainless steel
Stuffing box packing	PTFE chevrons
Disc seal	Bronze PTFE
Valve body seal	Graphite

OTHER MATERIALS

Operator Aluminium, nickel plated

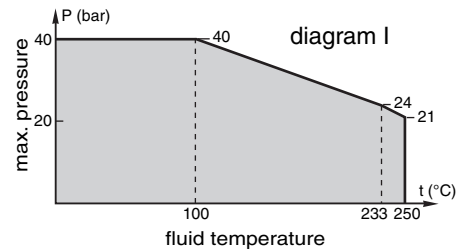

SPECIFICATIONS

DN	ext. pipe diameter (mm)	flow coefficient Kv								pilot pressure (bar)		operating pressure differential (bar)	operator diameter (mm)	catalogue number	
		mixer				distributor				min.	max.				
		3→2 (m³/h)	1→2 (l/min)	2→3 (m³/h)	2→1 (l/min)	2→3 (m³/h)	2→1 (l/min)	2→3 (m³/h)	2→1 (l/min)						
U - Universal															
15	22,4	3,3	54	4,4	73	3,5	59	4,6	78	*	10	40	80	S398A001	
20	27,7	8,0	133	7,4	123	8,1	136	7,7	129	*	10	40	100	S398A002	
25	34,5	11,4	190	11,6	194	12,1	203	11,9	199	*	10	40	100	S398A003	
32	43,2	18,9	316	16,6	278	17,9	299	16,6	278	*	10	40	150	S398A004	
40	49,5	27	450	27	450	27	450	27	450	*	10	40	150	S398A005	
50	62	51	850	51	850	51	850	51	850	*	10	40	200	S398A006	

* Minimum pilot pressure varies with differential pressure. See piloting charts above.

OPTIONS AND ACCESSORIES

- Metal-to-metal sealing disc
- ATEX 94/9/EC versions for potentially explosive atmospheres, categories 2 GD and 3 GD
- Valve seat leakage class VI as defined by FCI 70-2, contact us
- Other pipe connections are available on request

INSTALLATION

- The valves can be mounted in any position without affecting operation
- Compatible with ASTM 1, 2 and 3 oils
- The socket welding ends are according to EN 12760
- Installation/maintenance instructions are included with each valve

SPARE PARTS KITS

catalogue number	spare parts kit no.		
	piston seal	actuator spring	stem, disc, seals
S398A001	C140233	C140299	C140323
S398A002	C140234	C140301	C140324
S398A003	C140234	C140303	C140225
S398A004	C140235	C140305	C140326
S398A005	C140235	C140307	C140327
S398A006	C140298	C140309	C140328

ORDERING EXAMPLES / VALVES:

	S	398 A 003
	S	398 A 006
ext. pipe thread		
basic number		

ORDERING EXAMPLES / KITS:

	C140233
	C140298
	C140303
basic number	

DIMENSIONS (mm), WEIGHT (kg)



TYPE 01-02-03-04
Prefix "S"

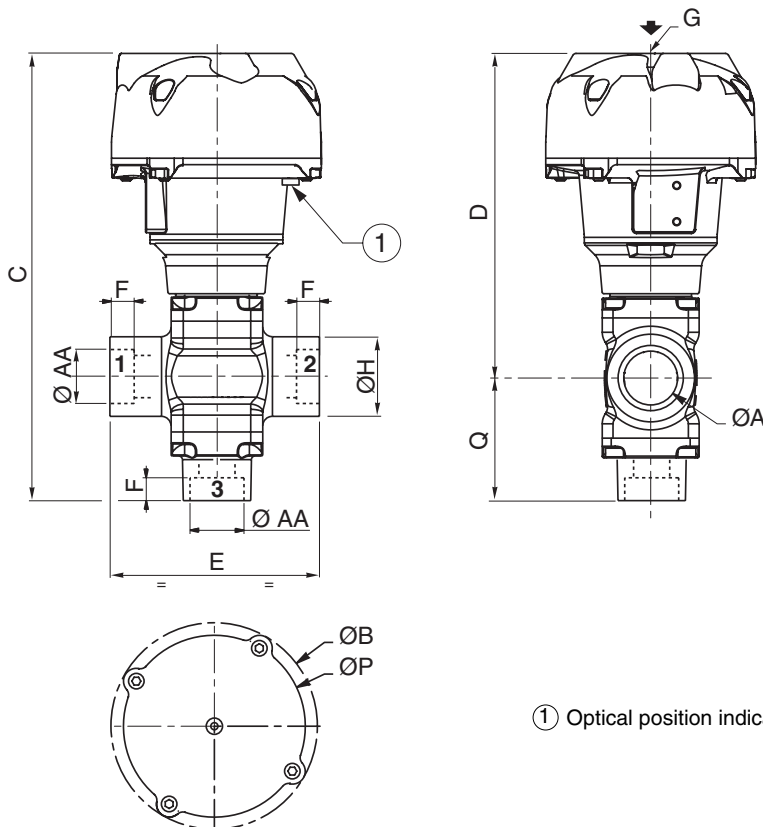

① Optical position indicator

type	DN	operator diameter	ØA	ØAA	ØB	C	D	E	F	G	ØH	ØP	Q	weight
01	15	80	15	22,4	110	203,1	151,6	85	9,5	G 1/8	33	95	51,5	1,87
02	20	100	20	27,7	132,5	229,2	170,9	110	11	G 1/8	40	117	58,3	3,51
	25	100	25	34,5	132,5	244,9	180,9	120	12,5	G 1/8	46	117	64	4,23
03	32	150	32	43,2	191	318,2	237,2	145	14,5	G 1/4	57	172,5	81	9,37
	40	150	40	49,5	191	361,7	259,2	150	16	G 1/4	65	172,5	102,5	11,9
04	50	200	50	62	247	436	328,5	190	17,5	G 1/4	75	230	107,5	23,66