

Designed to international and European standards.

GACHOT

These products have been designed, manufactured and tested under the supervision of an ISO 9001-2000 certified Quality Assurance system complying with:

- module H (categories I, II and III) of annex 3 of European Directive 97/23/EC concerning pressure equipment,
- module H (categories 1, 2) of European Directive 1999/36/EC concerning transportable pressure equipment;

and ensuring the products meet the safety and health essential requirements for the design and manufacturing of equipment intended for use in potentially explosive atmospheres according to the ATEX Directive 94/9/EC.

Features

- One piece ball valve which offers Gachot quality for servicing of utilities.
- Body material:
 - forged stainless steel
 - forged carbon steel
 - aluminium bronze
 - brass.
- Identical internal parts for steel and brass versions.
- Guided blow-out proof stem.
- Fully adjustable packing gland.
- Antistatic device to ISO 7121 and BS-5351.
- Can be equipped with pneumatic or electric actuators, double or single acting; mounting kits are available.
- Standard DIN 50049-3.1.B certificate available.
- Tightness to ISO 5208: Cat.A, bubble tight.
- Options:
 - special design for working pressure 150 bar (up to DN 20)
 - operating extension
 - cryogenic extension
 - handwheel
 - locking device (open/close)
 - special design for venting valve
 - welded on ISO top plate.



Applications

- Process and utilities services, sampling and gauge valve.
- Stainless steel: all corrosive chemical products (acids, alkaline, solvents).
- Carbon steel: steam, hot or cold water, compressed air and steam
- Brass: for all common fluids such as water, compressed air, oil, petrol, natural gas, butane, propane, low pressure steam.
- Aluminium-bronze: for sea water and sea water environment.
- V9 is particularly appreciated by the instrument departments.

Technical data

Sizes (mm)	: 8 - 25
Temperature (°C)	: -50 to +225
Pressure (bar)	: PN100
Body materials	: forged SS, CS aluminium bronze brass
Connections	: threaded ends BSPP and NPT. Upon request: butt weld and socket weld ends. Other connections such as BSPP Male.

Ball Valve Type V9

materials standard version

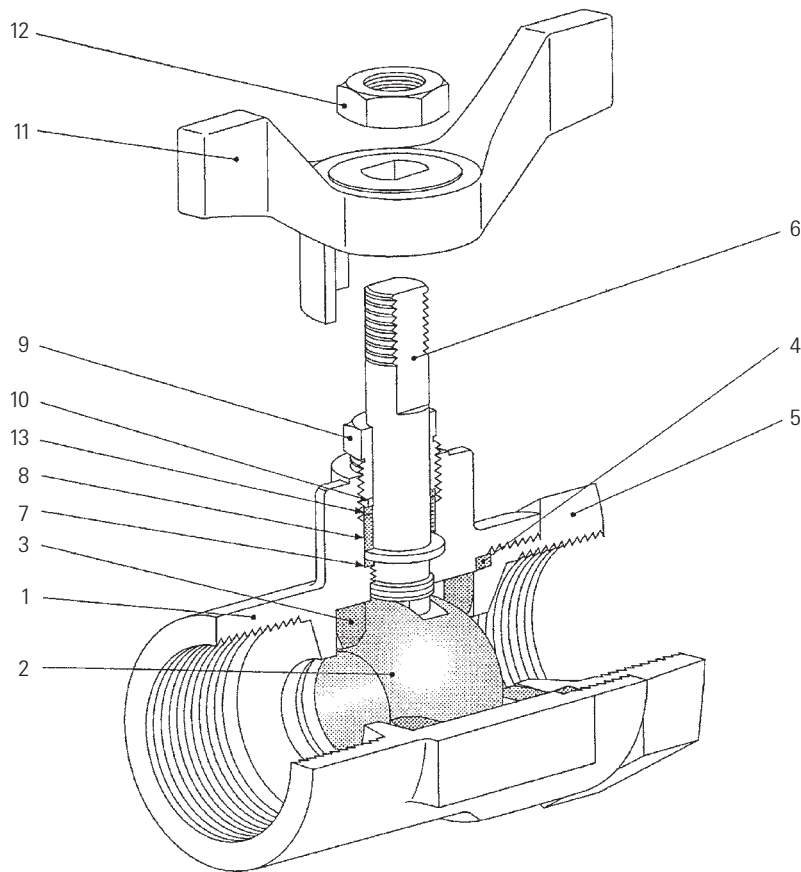

Packing and anti blow-out stem

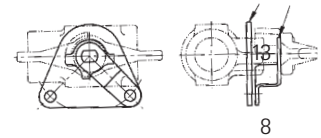

Antistatic device

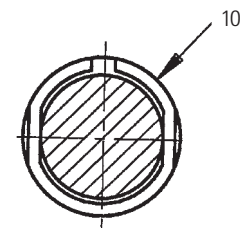

Parts list

Item	Qty	Description	Material				
			Stainless steel	Carbon steel	Brass	Aluminium-Bronze	
1	1	Body (forging)	ASTM A 182-F 316L	ASTM A 105	ASTM B 455-C 38500	UA 9 N5 FE forging	1*
2	1	Ball	AISI 316L	AISI 316L	AISI 316L	UA 9 N5 FE 1*	
3	2	Seat	TFE, Glass filled	TFE, Glass filled	FE, Glass filled	TFE, Glass filled	
4	1	Body seal	TFE	TFE	TFE	TFE	
5	1	Body end	AISI 316L	ASTM A 105 Gr 2	ASTM B 455-C 38500	UA 9 N5 FE 1*	
6	1	Stem	AISI 316L	AISI 316L	AISI 316L	UA 9 N5 FE 1*	
7	1	Friction washer	TFE	TFE	TFE	FE	
8	1	Gland packing	TFE	TFE	TFE	TFE	
9	1	Gland	AISI 316L	AISI 316L	ASTM B 455-C 38500	UA 9 N5 FE 1*	
10	1	Antistatic spring	AISI 316	AISI 316	AISI 316	AISI 316	
11	1	Lever (or handwheel)	ASTM A47 Gr 32510	ASTM A47 Gr 32510	ASTM A47 Gr 32510	ASTM A47 Gr 32510	
12	1	Handwheel nut	AISI 304	AISI 304	AISI 304	AISI 304	
13	1	Metalic washer	AISI 316L	AISI 316L	AISI 316L	AISI 316L	
14	1	Locking plate	AISI 304	AISI 304	AISI 304	AISI 304	
15	1	Movable plate	AISI 304	AISI 304	AISI 304	AISI 304	
16	1	ISO top plate	AISI 306L	ASTM A 306 Gr 55	-----	-----	

1* AFNOR standard



Ball Valve Type V9

dimensions standard version

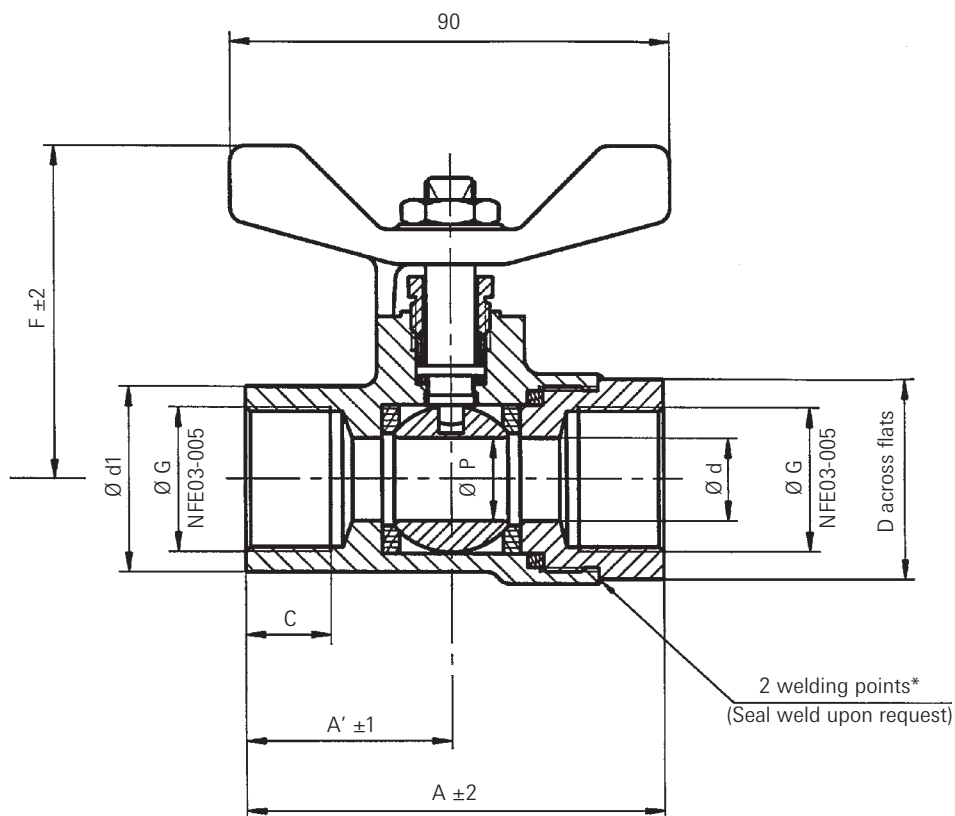

*For ALUMINIUM-BRONZE and BRASS: OXYSEAL glue

Valve dimensions (mm) - welded-on ISO top plate option

DN	ISO			D	F	d	d1	d3	BSPP		NPT		Weight	
	Top plate	P	A						A'	G	C	G	C	kg
08	F03	11	65	32	27	64	11	29	36	1/4"	11	1/4"	10.5	0.47
12	F03	11	65	32	27	64	11	29	36	3/8"	11.5	3/8"	10.5	0.45
15	F03	11	65	32	27	64	11	29	36	1/2"	15	1/2"	14	0.42
20	F03	14	70	35.5	35	66	14	31	36	1/2"	15	1/2"	14	0.42
25	F03	17	85	42	41	68	17	38	36	1"	19	1"	17.5	0.68

Welded-on ISO top plate option

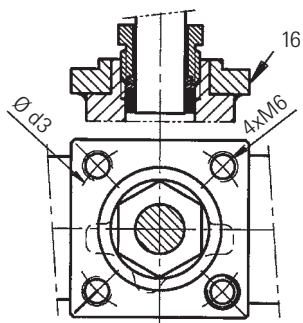

For carbon and stainless steel valves.

Locking device option (open or closed position)

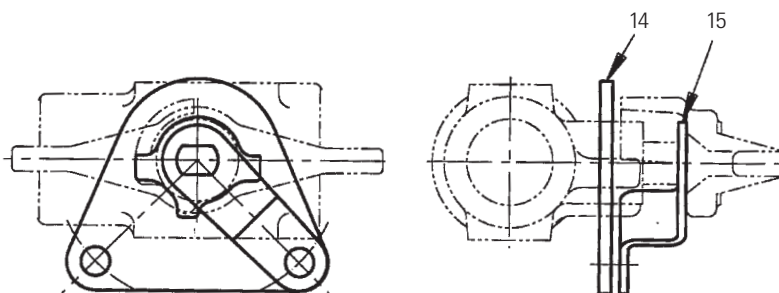

Pressure - temperature rating

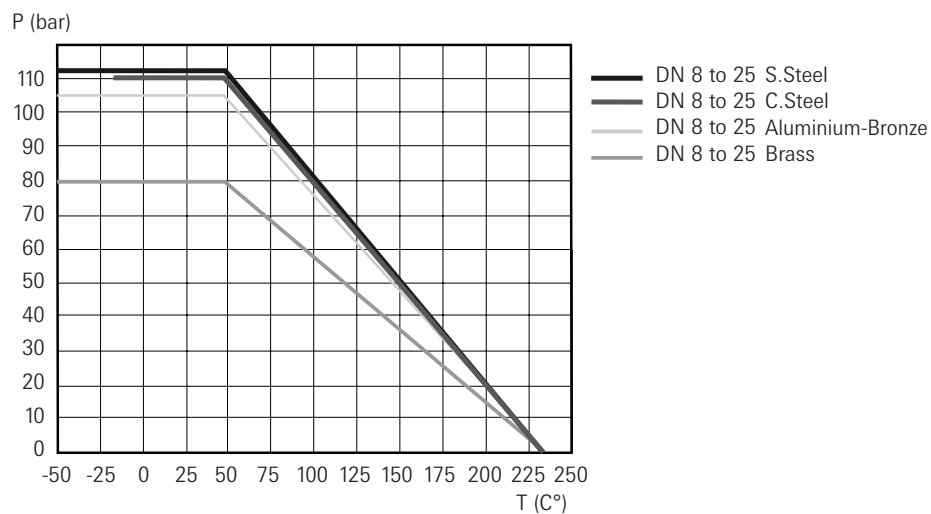

Testing

- 100% of our valves are standard tested according to the Gachot quality assurance manual: acceptance criteria according to: NFE-29311 - ISO 5208 - DIN 3230.
- Hydrostatic shell test: 1.5x pressure rating (ambient temperature). No visible leakage.
- Air seat test: pressure 6 bar air, (air in the valve body). No bubbles accepted.

Actuation and control

Actuation

- Pneumatic double acting and single acting actuators.
- Electric actuators.
- Electric actuators for special applications.

Control

- Various control devices (spool valves, limit switch box).
- Pneumatic, electro-pneumatic and intelligent positioners.

Torque values (Nm)

DN	ΔP			
	7	16	25	50
10	8	9	12	16
15	8	9	12	16
20	9	10	15	20
25	10	12	16	22

Flow coefficient Cv/Kv

Flow coefficient (to NFE 29-312)

DN	8	12	15	20	25
Cv	9	9	9	15	23
Kv	7.7	7.7	7.7	13	20

Selection of pneumatic actuators series 79/D for standard seats

DN	Air supply (bar)	Double Acting Actuator ΔP (bar)				Single Acting Actuator ΔP (bar)			
		7	16	25	50	7	16	25	50
Application I 10	4	003	003	003	003	006S-2.7	006S-2.7	006S-2.7	012S-2.7
	6	003	003	003	003	003S-5.5	003S-3.4	006S-3.4	006S-5.5
	8	003	003	003	003	003S-5.5	003S-5.5	003S-6.9	006S-5.5
15	4	003	003	003	003	006S-2.7	006S-2.7	006S-2.7	012S-2.7
	6	003	003	003	003	003S-5.5	003S-5.5	006S-3.4	006S-5.5
	8	003	003	003	003	003S-5.5	003S-5.5	003S-6.9	006S-5.5
20	4	003	003	003	006	006S-2.7	006S-2.7	012S-2.7	012S-2.7
	6	003	003	003	003	003S-5.5	003S-5.5	006S-5.5	006S-5.5
	8	003	003	003	003	003S-5.5	003S-5.5	006S-5.5	006S-5.5
25	4	003	003	003	006	006S-2.7	006S-2.7	012S-2.7	012S-3.4
	6	003	003	003	003	003S-5.5	006S-3.4	006S-5.5	012S-3.4
	8	003	003	003	003	003S-5.5	003S-6.9	006S-5.5	006S-6.9
Application II 10	4	003	003	003	006	006S-2.7	006S-2.7	012S-2.7	012S-2.7
	6	003	003	003	003	003S-5.5	006S-2.7	006S-5.5	006S-5.5
	8	003	003	003	003	003S-5.5	003S-6.9	006S-5.5	006S-5.5
15	4	003	003	003	006	006S-2.7	006S-2.7	012S-2.7	012S-2.7
	6	003	003	003	003	003S-5.5	006S-2.7	006S-5.5	006S-5.5
	8	003	003	003	003	003S-5.5	003S-6.9	006S-5.5	006S-5.5
20	4	003	003	003	006	006S-2.7	006S-2.7	012S-2.7	012S-2.7
	6	003	003	003	003	006S-2.7	006S-3.4	006S-5.5	012S-2.7
	8	003	003	003	003	003S-6.9	003S-6.9	006S-5.5	006S-6.9
25	4	003	003	003	006	006S-2.7	012S-2.7	012S-2.7	024S-2.7
	6	003	003	003	003	006S-3.4	006S-5.5	006S-5.5	012S-4.1
	8	003	003	003	003	003S-6.9	006S-5.5	006S-5.5	006S-8.2

Notes

Application I: Water and low viscosity liquids, temperature 20°C to 120°C standard service.

Application II: Dry fluids, high viscosity liquids, steam, oxygen service, heavy duty service, high temperature service.