

## SAPAG

## Sapag series 8400 and 8500 safety relief valves for API-526 process applications

### Applications

Sapag safety valves are a high quality engineered product suitable for all process applications where the protection of Plant against overpressurisation is required. Designs suitable for gas, steam and liquid applications are available.

### Design

The type 8400 is a conventional, flanged, full lift, angle pattern safety valve for use on gases and vapours. The type 8500 is the liquids application version of the type 8400. Balanced bellows versions are designated 8490 and 8590 respectively.

All valves are designed constructed and tested in accordance with the requirements of API 520,526 and 527.

The performance of all valve types has been certified by independent bodies :

- "UV" stamp (certification in accordance with the rules of the ASME code, section VIII) with capacity certification for air, steam and water.
- Other International approvals.

### Features

The following features have been incorporated and contribute to an extended service life, reduced cost of ownership and a superior application versatility

- Improved, rugged nozzle ring design.
- Improved disc insert retention for ease of maintenance.
- Standard Inconel 625 bellows and flange material for superior corrosion resistance, longer service life and a wider range of applications.
- Universal disc holder allows for simple and cost-effective conversions from conventional to balanced bellows design.
- Standard threaded bellows design for ease of maintenance and conversion from conventional to balanced bellows design.
- Improved corrosion resistance with standard 316 stainless steel adjusting bolt lock nut and nozzle ring set screw materials.
- Field proven liquid trim style for stable, non-chattering operation on liquid and gas service.
- Standard chrome steel spring for an operating range of -28°C to +343°C.



- Easily converted to any type cap or lifting lever construction, liquid trim, soft-seat or balanced bellows configurations.
- Test Gag/Plug supplied as standard.

### Technical Data

Sizes	: 1" D 2" to 8" T 10"
Orifices	: 71 to 16774 mm <sup>2</sup>
Inlet Ratings	: ANSI Class 150, 300, 600, 900, 1500, 2500
Temperature Range	: -268°C to +538°C
Pressure Range	: 1.03 to 413.79 barg

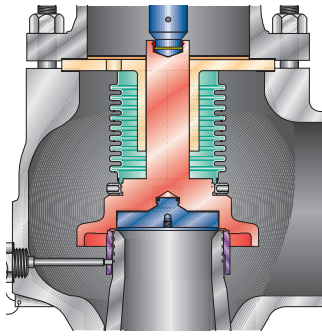

**Bellows**

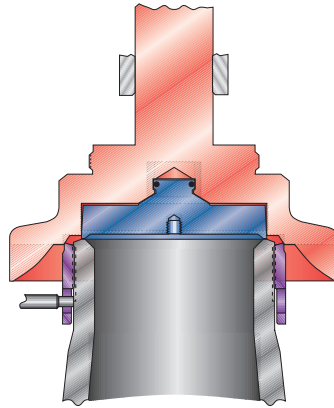

**Liquid Trim**

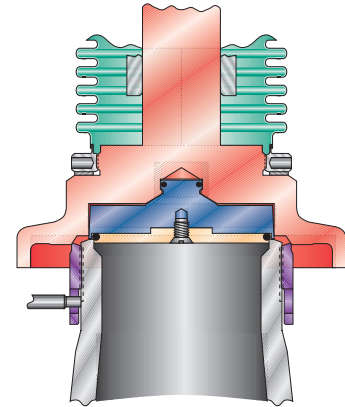

**O Ring Seat Design**

## Bellows

Types 8490 and 8590 balanced bellows valves provide optimum valve performance when the developed back pressure in exhaust systems or discharge manifolds becomes excessive. Manufactured from Inconel 625 fatigue-resistant material, the bellows provides improved corrosion resistance compared to 316L stainless steel. A universal threaded disc holder allows for simple conversion from conventional to bellows valve as well as cost-effective bellows replacement.

## Liquid Trim

The 8500 design is capacity certified on gas and vapor service and can be applied in two-phase flow applications. This seat configuration offers a significant increase in capacity at 10% overpressure resulting in the economic use of a smaller valve which, in turn, represents a reduction in inlet and discharge piping costs.

## Seat Design

All styles can be provided with flat metal-to-metal seats or soft seats. The two piece construction of the disc holder/disc insert provides thermal balancing and assures maximum seat tightness in accordance with the requirements of API Standard 527.

Where system operating conditions permit, soft seat or elastomer seat construction is available as an option.

## Valve Styles

8400	8500
8490	8590
8470	8570
8420	

Sapag Styles 8400 and 8500 are the conventional designs for applications where the discharge is to atmosphere or where the discharge is to a low pressure exhaust system designed to contain the process fluid. Valves subject to flashing fluids may require a balanced bellows type valve

This exceptionally rugged design features a high guiding surface ratio, corrosion resistant trim, high grade materials of construction and several other design attributes characterise ease of maintenance and a great degree of parts interchangeability.

Sapag Styles 8490 and 8590 incorporate a bellows which is balanced to minimize the effect of back pressure on the performance characteristics. The balanced bellows design offsets the effects of variable back pressure on valve set pressure. The balanced bellows valve can also handle applications involving high built-up back pressure.

Additionally, the bellows serves to isolate the guide, spindle, spring and other parts contained in the bonnet chamber from corrosive fluids or media such as a highly viscous fluid or slurry which could render the safety valve inoperative.

**Style 8400-OR  
(with O-Ring seat)**

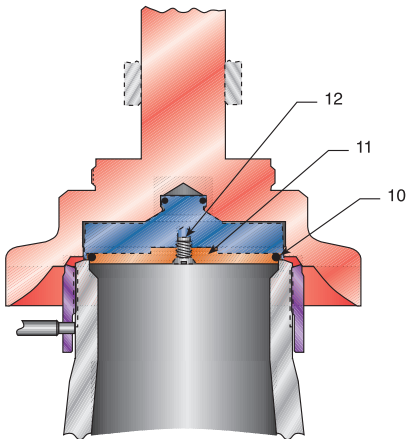

**Style 8400**

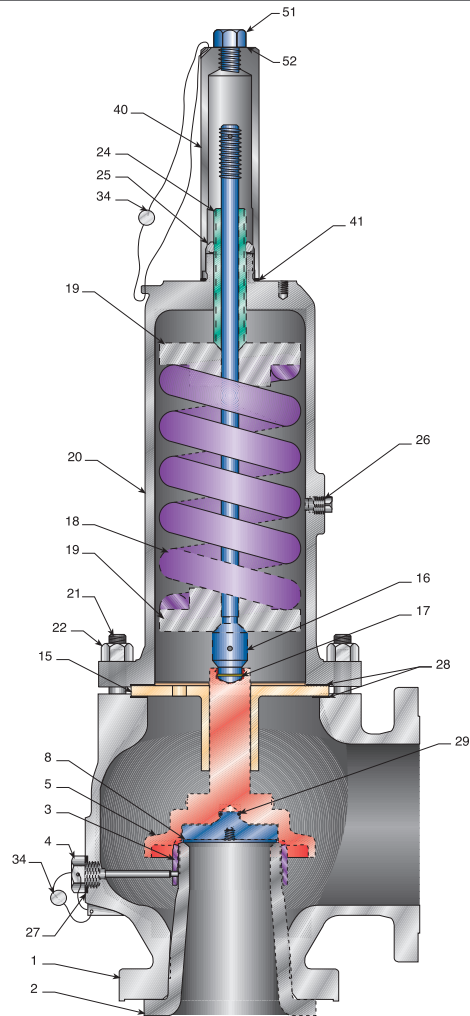

**Notes**

1. Subassembly (Styles 8490 & 8590 only)
2. Recommended Spare Part.
3. Furnished with Disc Insert.
4. Corrosion resistant coating.
5. May upgrade to Inconel X750.
6. Class 900#, 1500# and 2500# inlet ratings use 416 Stainless Steel.

**Styles 8400, 8490, 8500 and 8590 standard materials of construction**

Ref. No.	Part Name	Standard Material
1	Body (8400,8490,8500 and 8590)( )5 and ( )6	ASME SA216 GR. WCB
1	Body (8400,8490, 8500 and 8590)( )7	ASME SA217 GR. WC6
2	Nozzle	316 Stainless Steel
3	Nozzle Ring	316 Stainless Steel
4	Set Screw	316 Stainless Steel
5	Disc Holder	316L Stainless Steel
6A	Bellows Tailpiece <sup>1</sup> (not shown)	316L Stainless Steel
6B	Bellows <sup>1</sup> (not shown)	Inconel 625
6C	Bellows Flange <sup>1</sup> (not shown)	Inconel 625
8	Disc Insert <sup>2</sup>	316 Stainless Steel
9	Retention Clip <sup>3</sup>	Inconel X750
10	O-ring <sup>2</sup>	Specify
11	O-ring Retainer	316 Stainless Steel
12	Retainer Screws	316 Stainless Steel
15	Guide	ASTM A297 GR. HE SST
16	Spindle	416 Stainless Steel
17	Spindle Cotter Pin	Stainless Steel
18	Spring (8400,8490,8500 and 8590)( )5 and ( )6	Chrome Steel <sup>4</sup>
18	Spring (8400,8490,8500 and 8590)( )6 and ( )7	Alloy Steel <sup>4 and 5</sup>
19	Spring Washers	Carbon Steel
20	Bonnet (8400,8490,8500 and 8590) ( )5 and ( )6	ASME SA216 GR. WCB
20	Bonnet (8400,8490,8500 and 8590) ( )7	ASME SA217 GR. WC6
21	Bonnet Stud	ASME SA193 GR. B7
22	Bonnet Stud Nut	ASME SA194 CL 2H
24	Adjusting Bolt	316 Stainless Steel <sup>6</sup>
25	Adjusting Bolt Nut	316 Stainless Steel
26	Pipe plug	Carbon Steel
27	Set Screw Gasket <sup>2</sup>	Organic Fiber Non-Asbestos
28	Guide Gasket <sup>2</sup>	Organic Fiber Non-Asbestos
29	Tailpiece Gasket <sup>2</sup> (not shown)	Organic Fiber Non-Asbestos
34	Seal and Wire	Lead and Stainless Steel
35	Seal Clip (not shown)	Stainless Steel
40	Threaded Cap	Carbon Steel
41	Cap Gasket <sup>2</sup>	Organic Fiber Non-Asbestos
51	Test Gag/Plug (Plug only shown)	Carbon Steel
52	Test Gag Plug Gasket	Organic Fiber Non-Asbestos

## Style 8490

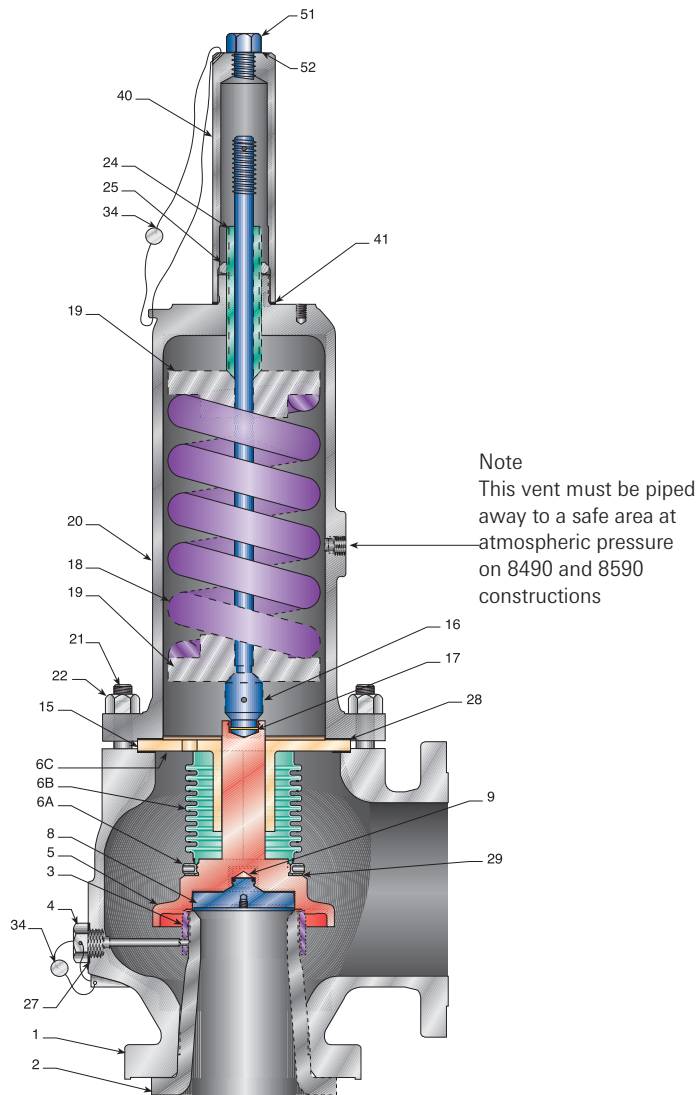

Note  
This vent must be piped away to a safe area at atmospheric pressure on 8490 and 8590 constructions

Styles 8400 and 8500  
Conventional and balanced safety valves for sour gas service per NACE MR0175

### Level 1

For applications where compliance with NACE MR0175 is required for wetted parts in the primary (upstream) pressure zone of the safety valve.

Materials of construction for Level 1 can be found on page 3.

### Level 2

For applications where compliance with NACE MR0175 is required for wetted parts in the primary (upstream) and secondary (downstream) pressure zones of the safety valve.

While the materials recommended for the Sapag Style 8400, 8490, 8500 and 8590 sour gas valves are suitable for average service conditions, optional materials are available to provide additional resistance to corrosion beyond the minimum requirements of the standard.

### Material specification 8400, 8490, 8500 and 8590

Ref No.	Part Name	Standard NACE Material Level 2
1	Body	ASME SA216 GR. WCB
2	Nozzle	316 Stainless Steel
3	Nozzle Ring	316 Stainless Steel
4	Set Screw	316 Stainless Steel
5	Disc Holder	316L Stainless Steel
6A	Bellows Tailpiece <sup>1</sup>	316L Stainless Steel
6B	Bellows <sup>1</sup>	Inconel 625
6C	Bellows Flange <sup>1</sup>	Inconel 625
8	Disc Insert <sup>2</sup>	316 Stainless Steel
9	Retention Clip <sup>3</sup>	Inconel X750
15	Guide	ASTM A297 GR. HE SST
16	Spindle	416 Stainless Steel <sup>4</sup>
17	Spindle Cotter Pin	Stainless Steel
18	Spring	Chrome Steel-Aluminised <sup>5</sup>
19	Spring Washer	Steel <sup>4</sup>
20	Bonnet	ASME SA216 GR. WCB
21	Bonnet Stud	Alloy Steel <sup>7</sup>
22	Bonnet Stud Nut	Steel <sup>7</sup>
24	Adjusting Bolt	316 Stainless Steel <sup>6</sup>
25	Adjusting Bolt Nut	316 Stainless Steel
27	Set Screw Gasket <sup>2</sup>	Organic Fiber Non-Asbestos
28	Guide Gasket <sup>2</sup>	Organic Fiber Non-Asbestos
29	Tailpiece Gasket	Organic Fiber Non-Asbestos
34	Seal and Wire	Lead and Stainless Steel
35	Seal Clip (not shown)	Stainless Steel
40	Threaded Cap	Carbon Steel
41	Cap Gasket <sup>2</sup>	Organic Fiber Non-Asbestos
51,52	Test Gag/Plug (Plug only shown)	Carbon Steel

### Notes

1. Subassembly (Styles 8490 & 8590 only)
2. Recommended Spare Part.
3. Furnished with Disc Insert.
4. 316 Stainless Steel on styles 8400 & 8500.
5. Inconel X750 standard on styles 8400 & 8500.
6. Class 900#, 1500# and 2500# inlet ratings use 416 Stainless Steel (styles 8490 & 8590 only).
7. If Class I or II bolting is required, bonnet studs will be ASME A193 Gr B7M HRC-22 maximum and bonnet stud nuts will be ASME A194 Class 2HM HRC-22 maximum.

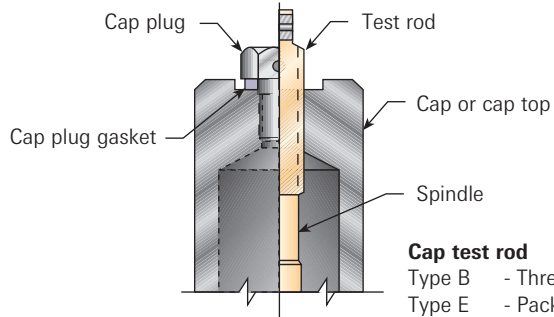

**Cap test rod**

- Type B - Threaded cap (Low profile)
- Type E - Packed lifting lever
- Type H - Bolted cap (Low profile)
- Type K - Threaded cap (standard)
- Type M - Bolted cap (standard)

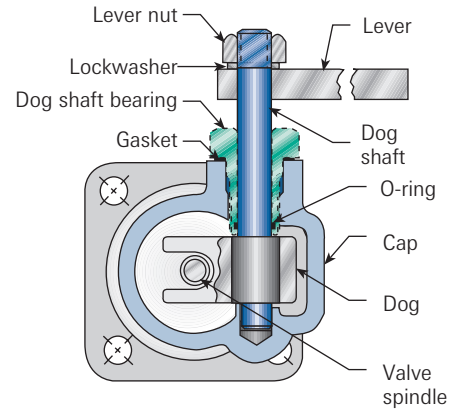
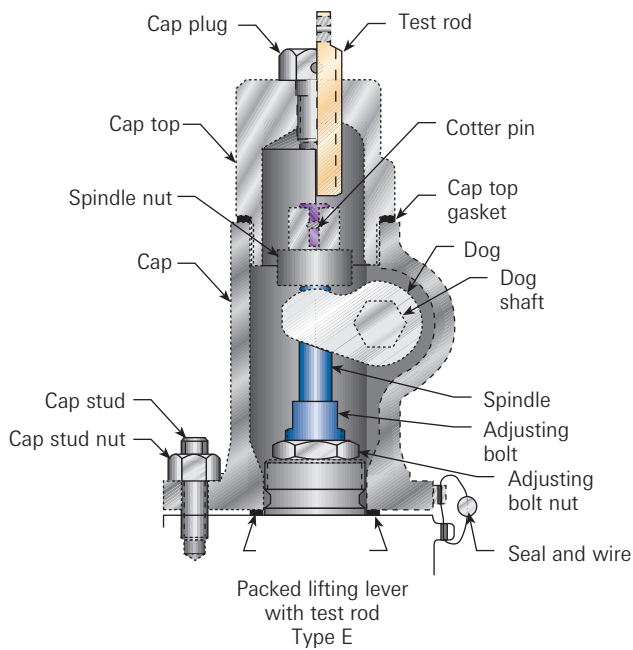

**Packed lifting lever**

Type E  
(Top view)

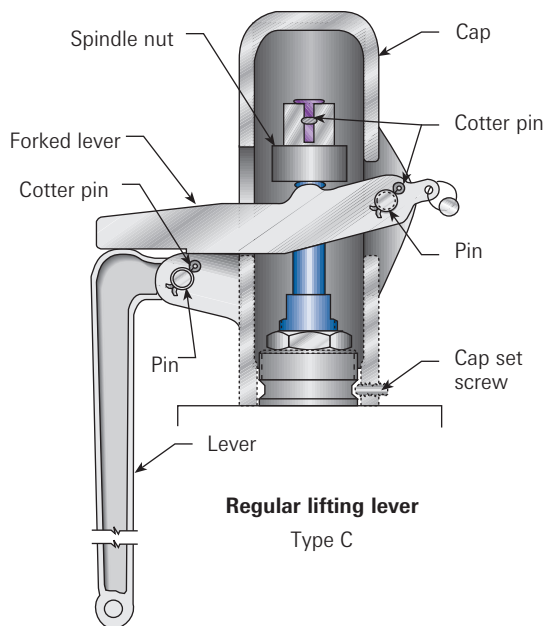



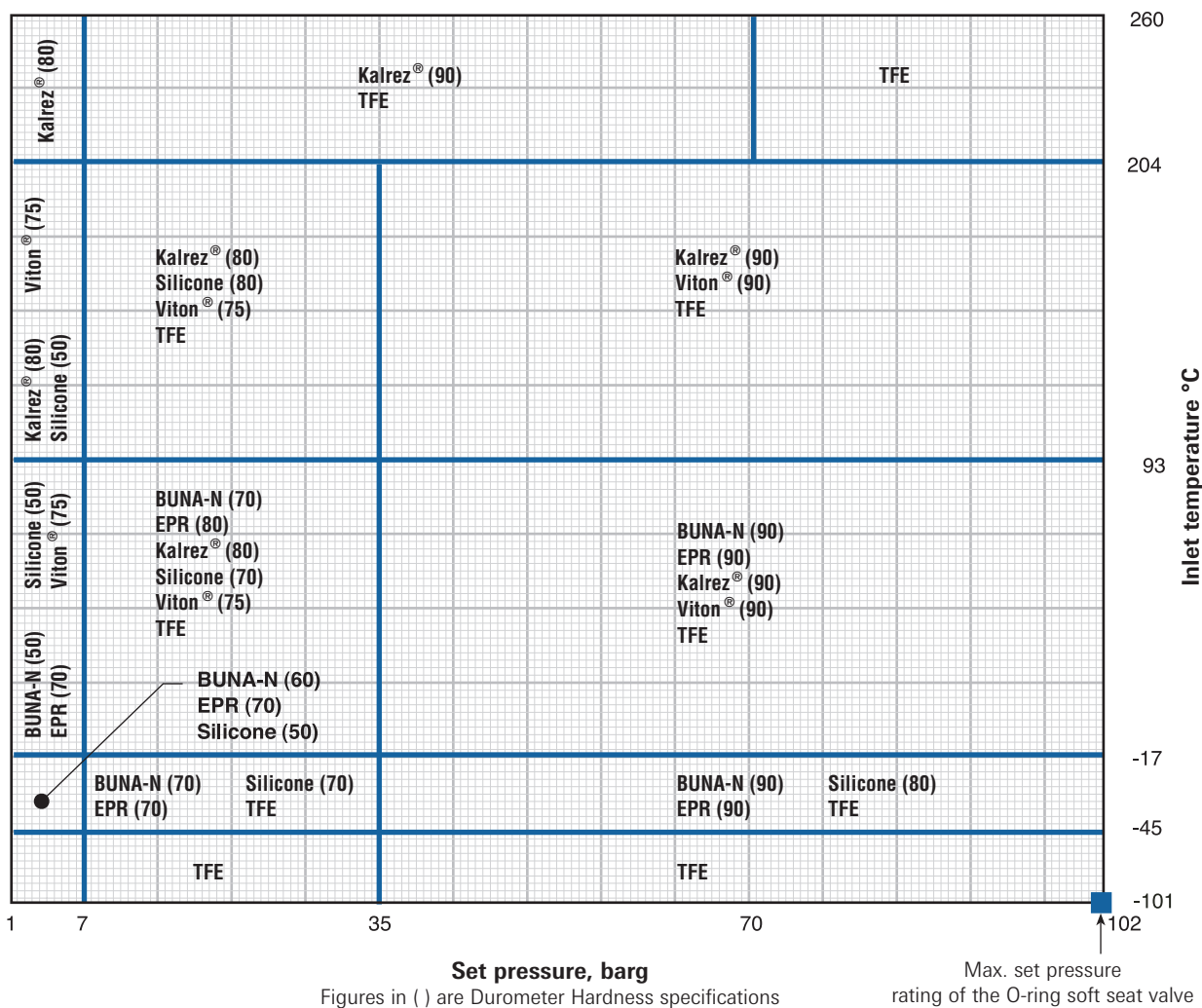

**Notes**

- EPR = Ethylene Propylene Rubber
- TFE = Tetrafluoroethylene
- Other soft seat materials are available on request. For O-ring seats below -150°F [-101°C] consult Sapag. For steam service, metal-to-metal seats are recommended consult the factory.

**Maximum set pressure limits**

Maximum Set Pressure	
Orifice	barg
D	102
E	102
F	102
G	102
H	102
J	102
K	102
L	68.9
M	75.8
N	68.9
P	68.9
Q	41.3
R	20.6
T	20.6

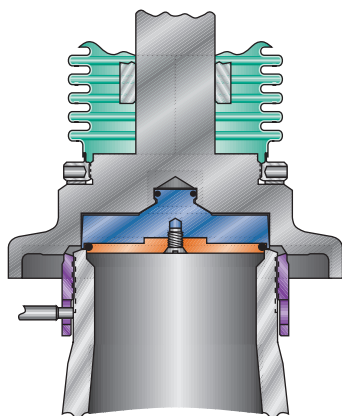

**8490-OR  
Soft Seat**

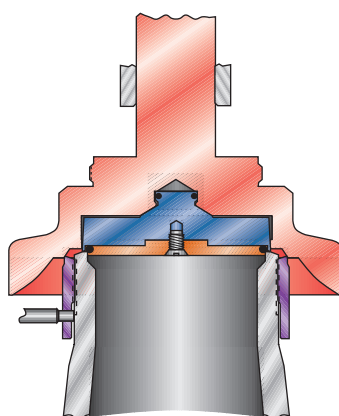

**8500-OR  
Soft Seat**

Size Inlet x Orifice x Outlet	Style	Pressure/Temperature Inlet Flange Range Ratings		Seat Type	Material Variations	Caps and Lifting Levers (Type)
1" D 2" thru 8" T 10"	<b>8400</b> Conventional	1 - Cl 150 Flange	2 - -268°C to -60°C	None - Metal "OR" - O-Ring  When ordering soft seats, specify material.	None - Standard Materials	Type K - Threaded cap with test rod
	<b>8490</b> With bellows	2 - Cl 300 Flange <sup>1)</sup>	4 - -59°C to -30°C			
	<b>8500</b> Conventional with liquid trim	3 - Cl 300 Flange	5* - -29°C to +343°C		S - All 316 St. St.	Type C - Regular lifting lever
	<b>8590</b> Bellows with liquid trim	4 - Cl 600 Flange <sup>2)</sup>	6 - +344°C to +427°C		S4 - All 316 St. St. except body, bonnet, cap and spring	Type E - Packed lifting lever with test rod
	<b>8470</b> Bellows with back pressure balancing piston	5 - Cl 900 Flange	7 - +428°C to +538°C		M - All Monel with Monel or Inconel spring	Type M - Bolted cap with test rod
	<b>8570</b> Bellows with liquid trim and back pressure balancing piston	6 - Cl 1500 Flange	* Except Style 8420 with open bonnet, chrome steel spring used to 427°C		M1 - Monel nozzle and disc insert	<b>Optional Caps for Height Restricted Applications</b> Type B - Threaded cap with test rod
	<b>8420</b> Conventional 8400 with open bonnet for ASME Code Section VIII steam service to +427°C	7 - Cl 2500 Flange			M4 - All Monel except body, bonnet, cap, spring and washers	
		1) Lightweight Cl.300 flange per API-526			M5 - All Monel except spring and washers	
		2) Except 'T' orifice is Cl.300 flange			H - All Hastelloy C	
					H1 - Hastelloy C nozzle and disc insert	
					H4 - All Hastelloy C except body, bonnet, cap, spring and washers	
					H5 - All Hastelloy C except spring and washers	
					N2 - NACE Level 2 <b>8400</b> Inconel X750 spring, 316 St. St. washers, spindle and adjusting bolt <b>8490</b> Aluminised Spring	

# 8400/8500/8490/8590 Safety Valve

## Dimensions and Weights (Carbon Steel styles only) Metric Units

Pressure and Temperature ratings are per API-526

Inlet x Outlet	Orifice	A	B	C	S	kg
1"-150 x 2"-150"	D,E	104,8	114,3	514	40	16
1"-300 x 2"-150" *		104,8	114,3	514	40	16
1"-300 x 2"-150"		104,8	114,3	514	40	16
1"-600 x 2"-150"		104,8	114,3	514	40	16
1 1/2"-900 x 2"-300"		104,8	139,7	533	51	29
1 1/2"-1500 x 2"-300"		104,8	139,7	533	51	29
1 1/2"-2500 x 3"-300"		139,7	177,8	565	64	36
1 1/2"-150 x 2"-150"	F	123,8	120,6	603	44	23
1 1/2"-300 x 2"-150" *		123,8	120,6	603	44	23
1 1/2"-300 x 2"-150"		123,8	152,4	603	44	23
1 1/2"-600 x 2"-150"		123,8	152,4	603	44	23
1 1/2"- 900 x 3"-300"		123,8	165,1	597	51	31
1 1/2"-1500 x 3"-300"		123,8	165,1	597	51	31
1 1/2"- 2500 x 3"-300"		139,7	177,8	692	64	41
1 1/2"-150 x 3"-150"	G	123,8	120,7	603	44	25
1 1/2"-300 x 3"-150" *		123,8	120,7	603	44	25
1 1/2"-300 x 3"-150"		123,8	152,4	603	44	25
1 1/2"-600 x 3"-150"		123,8	152,4	603	44	25
1 1/2"-900 x 3"-300"		123,8	165,1	673	51	34
2"-1500 x 3"-300 "		155,6	171,5	699	70	90
2"-2500 x 3"-300"		155,6	171,5	699	70	90
1 1/2"-150 x 3"-150"	H	130,2	123,8	610	43	25
1 1/2"-300 x 3"-150" *		130,2	123,8	610	43	25
2"-300 x 3"-150"		130,2	123,8	610	46	27
2"-600 x 3"-150"		154	161,9	692	46	34
2"-900 x 3"-150"		154	161,9	730	59	50
2"-1500 x 3"-300 "		154	161,9	730	59	50
2"-150 x 3"-150"	J	136,5	123,8	616	43	30
2"-300 x 3"-150" *		136,5	123,8	616	43	30
3"-300 x 4"-150"		184,2	181	739	68	42
3"-600 x 4"-150"		184,2	181	790	68	54
3"-900 x 4"x 150"		184,1	181	838	68	70
3"- 1500 x 4"-300"		184,1	181	838	68	70
3"-150 x 4"-150"	K	155,6	161,9	768	54	52
3"-300 x 4"-150" *		155,6	161,9	768	54	52
3"-300 x 4"-150"		155,6	161,9	768	54	53
3"-600 x 4"-150"		184,1	181	851	54	73
3"-900 x 6"x 150"		198,4	215,9	1003	68	84
3"-1500 x 6"-300"		196,8	215,9	1003	68	88
3"-150 x 4"-150"	L	155,6	165,1	876	51	69
3"-300 x 4"-150" *		155,6	165,1	876	51	69
4"- 300 x 6" - 150"		179,4	181	876	54	87
4"-600 x 6"-150"		179,4	203,2	908	60	103
4"-900 x 6"-150"		196,8	222,2	1022	75	122
4"-1500 x 6"-150"		196,8	222,2	1022	75	122
4"-150 x 6"-150"	M	177,8	184,1	864	54	91
4"-300 x 6"-150" *		177,8	184,1	864	54	91
4"-300 x 6"-150"		177,8	184,1	927	54	101
4"-600 x 6"-150"		177,8	203,2	1080	62	120
4"-900 x 6"-150"		196,8	222,2	1099	65	132
4"-150 x 6"-150"	N	196,8	209,5	1111	54	118
4"-300 x 6"-150" *		196,8	209,5	1111	54	118
4"-300 x 6"-150"		196,8	209,5	1111	54	127
4"-600 x 6"-150"		196,8	222,2	1111	60	135
4"-150 x 6"-150"	P	181	228,6	1092	54	122
4"-300 x 6"-150" *		181	228,6	1092	54	122
4"-300 x 6"-150"		225,4	254	1137	54	130
4"-600 x 6"-150"		225,4	254	1194	65	182
6"-150 x 8"-150"	Q	239,7	241,3	1226	59	218
6"-300 x 8"-150" *		239,7	241,3	1226	59	218
6"-300 x 8"-150"		239,7	241,3	1226	59	223
6"-600 x 8"-150"		239,7	241,3	1327	75	256
6"-150 x 8"-150"	R	240	241	1365	59	256
6"-300 x 8"-150" *		240	241	1365	59	256
6"-300 x 10"-150"		240	267	1365	59	273
6"-600 x 10"-150"		240	267	1365	70	286
8"-150 x 10"-150"	T	276,2	279,4	1524	65	400
8"-300 x 10"-150" *		276,2	279,4	1524	65	400
8"-300 x 10"-150"		276,2	279,4	1524	65	409
8"-300 x 10"-150"		276,2	279,4	1524	65	422

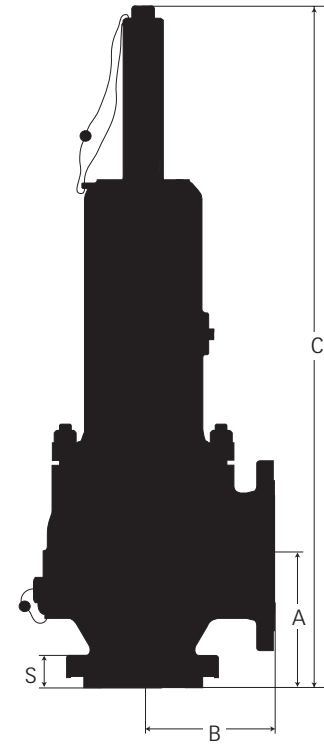

### Notes

1. Pressure and Temperature ratings are per API-526.
  2. Height shown ("C") is for standard type K threaded cap (plugged position shown without test rod). See also page 5.
  3. Pre 1995 API-526 2 1/2" connections available for D,E,F,G and J orifice in place of current 3" size.
- \* Lightweight Cl.300 rating per API-526 (Cl.150 rated body).