

## BIFFI

### Double acting pneumatic quarter-turn actuator for output torques to 248,500 Nm.

#### Features and Benefits

- Scotch yoke design generates high break torque needed for the actuation of many quarter-turn valves.
- Six bearings provide reliability, smooth operation and extended service life:
  - Two bronze yoke bearings ensure minimal friction.
  - Two bronze sliding block bearings spread load over large surface area.
  - Guide block bearing and piston rod bearing of sintered bronze impregnated with PTFE increase efficiency, reduce maintenance and prolong actuator life.
- Graphite-impregnated PTFE piston bearing reduces friction between the piston and cylinder bore and allows the cylinder to be operated without lubrication.
- Guide bar supports the transverse forces and insures proper support of the piston rod. Hard chrome plating on guide bar provides corrosion resistance and minimal friction loads.
- Chrome-plated piston rods provide maximum corrosion resistance and minimal friction loads on dynamic seals.
- Electroless nickel-plated cylinder bore provides maximum corrosion resistance and reliability.
- Multiple external tie bar design provides maximum cylinder integrity.
- Totally enclosed, weatherproof carbon steel housing provides maximum strength. Internal coating protects against corrosion.
- External travel stops allow precise adjustments of  $\pm 4^\circ$  rotation at each end of travel.
- Low hysteresis and high response enhance modulating service.
- Available with canted or with symmetric scotch yoke mechanism to suit the valve characteristics.
- Special coatings for offshore or corrosive environments.
- Special version available for use with sour gas supply.
- ATEX certified  II 2 G D



#### Options and accessories

- Accessory mounting brackets provided for mounting of controls or enclosures.
- Manual jackscrews and hydraulic manual overrides optional.
- Spring return actuators available.

#### General application

Designed for on-off or modulating control of quarter-turn ball, butterfly, plug or damper style valves.

#### Technical Data

Supply pressure	: 1.5 to 10.5 bar
Supply medium	: air, nitrogen or sweet gas
Output torque	: to 248,500 Nm
Ambient temperature	
standard range	: -30°C to +100°C (-20°F to +210°F)
optional ranges	: -55°C to +150°C (-65°F to +300°F)

# Alga Double Acting Pneumatic Actuator Scotch Yoke Design

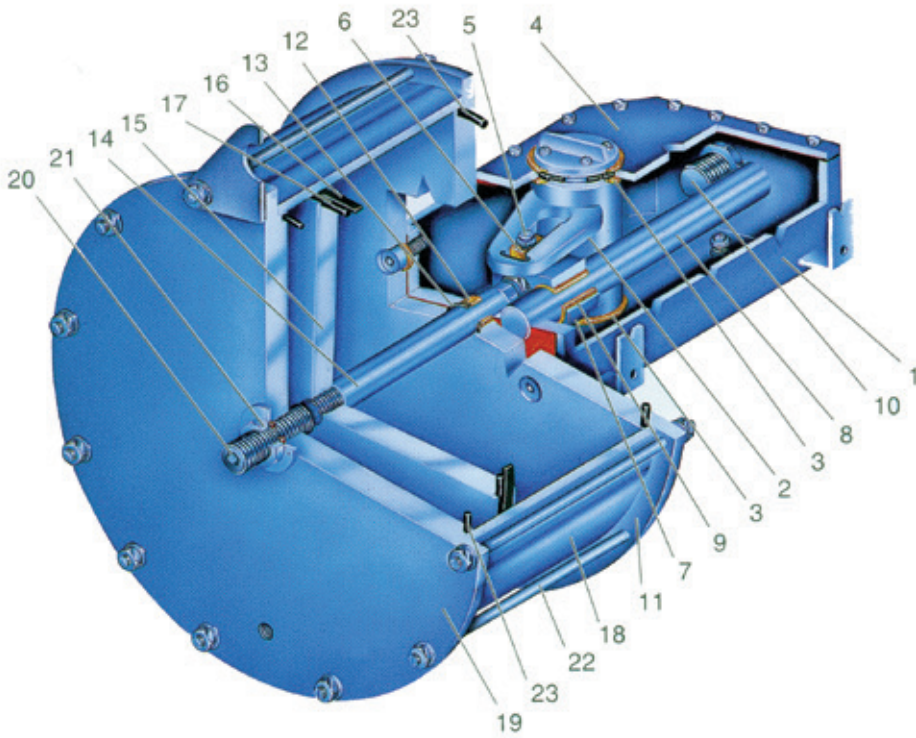

## Materials

Part	Material	Material Standards
1 Housing	Carbon steel	ASTM A537 cl1 + ASTM A283 gr D
2 Yoke	Carbon steel	API 5LX gr X52 (C<0.2%) + ASTM A537 cl1
3 Yoke bearing	Bronze	ASTM B427 Alloy UNS No. C90800
4 Cover	Carbon steel	ASTM A283 gr D
5 Guide block pin	Alloy steel	AISI SAE 9840
6 Sliding block	Bronze	ASTM B427 Alloy UNS No. C90800
7 Guide block	Carbon steel	ASTM A537 cl1
8 Guide bar	Alloy steel (hard chrome plated)	AISI SAE 9840 (chromium plated)
9 Guide block bearing	Steel + bronze + PTFE	-
10 Travel stop screw	Carbon steel	AISI SAE 1040
11 Cylinder head flange	Carbon steel	ASTM A283 gr D
12 Piston rod bearing	Steel + bronze + PTFE	-
13 Piston rod seal	NBR rubber	-
14 Piston rod	Alloy steel (hard chrome plated)	AISI SAE 9840
15 Piston	Carbon steel	ASTM A283 gr D
16 Piston bearing	PTFE + graphite	-
17 Piston seal O-ring	NBR rubber	-
18 Cylinder tube	Carbon steel (ENP)	API 5LX GR X52
19 Cylinder end flange	Carbon steel	ASTM A283 gr D
20 Travel stop screw	Carbon steel	AISI SAE 1040
21 Sealing washer	PVC	-
22 Tie rod	Alloy steel	AISI SAE 9840
23 Cylinder seal O-ring	NBR rubber	-

# Alga Double Acting Pneumatic Actuator

## Overall dimensions

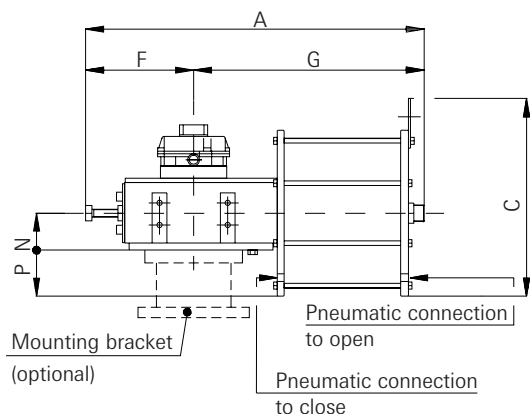

Top view

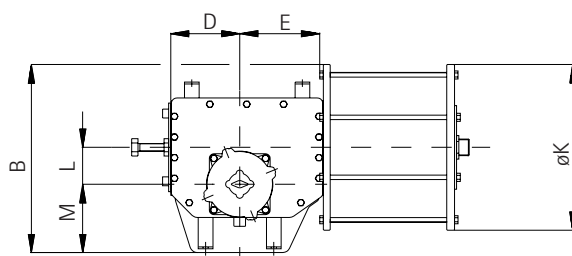

### Dimensions (mm)

Model	A	B	C	D	E	F	G	øK	L	M	N	P	Pneumatic connections		Weight kg
													to close NPT	to open NPT	
0.3*-135	731	319	296	136	149	222	509	∅ 154	70	119	70	7	1/4	1/4	53
0.3*-175	744	319	306	136	151	222	522	∅ 200	70	119	70	30	1/4	1/2	64
0.3*-235	748	319	336	136	138	222	526	∅ 260	70	119	70	60	1/2	1/2	82
0.9*-235	810	413	347	160	190	245	565	∅ 260	80	170	83	47	1/2	1/2	94
0.9*-280	807	423	390	160	190	245	562	345	80	170	83	90	1/2	3/4	124
1.5*-280	926	462	510	187	217	293	633	345	100	185	100	73	1/2	3/4	166
1.5*-335	926	484	478	187	217	293	633	400	100	185	100	100	1/2	1	194
1.5*-385	920	510	536	187	217	293	627	450	100	185	100	125	1/2	1	227
3*-385	1305	600	536	285	320	391	914	450	160	215	106	119	1/2	1	308
3*-485	1312	655	640	285	317	391	921	560	160	215	106	174	3/4	1	388
6*-485	1499	725	640	327	366	430	1069	560	185	260	140	140	3/4	1	512
6*-585	1504	780	758	327	366	430	1074	670	185	260	140	195	3/4	1	704
14*-635	1673	855	809	376	422	496	1177	720	200	295	193	167	1	1	1250
18*-685	1956	955	889	422	475	548	1408	770	230	340	196	189	1	1	1550
18*-735	1956	978	941	422	475	548	1408	815	230	340	196	212	1	1	1650

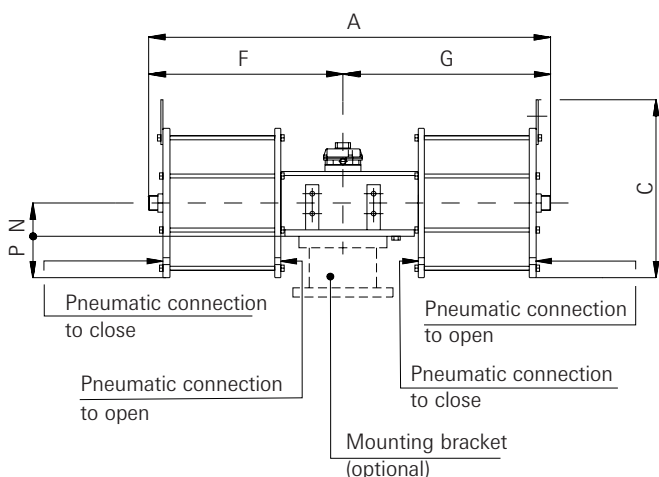

Top view

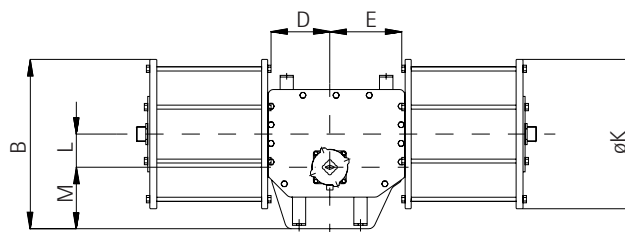

### Dimensions (mm)

Model	A	B	C	D	E	F	G	øK	L	M	N	P	Pneumatic connections		Weight kg
													to close NPT	to open NPT	
18*2-635	2690	935	814	397	465	1310	1380	730	230	340	196	169	1	1	1950
32*2-685	3110	1050	889	488	568	1515	1595	770	270	395	232	153	1	1	2450

### Notes

- \* Add C for canted yoke, S for symmetric yoke (i.e. 0.3C-135).
- Dimensions and weights given are without optional bracket or adaptor flange.
- For mounting flange details see separate coupling dimensions leaflet.

### Actuator models 0.3 to 6.0

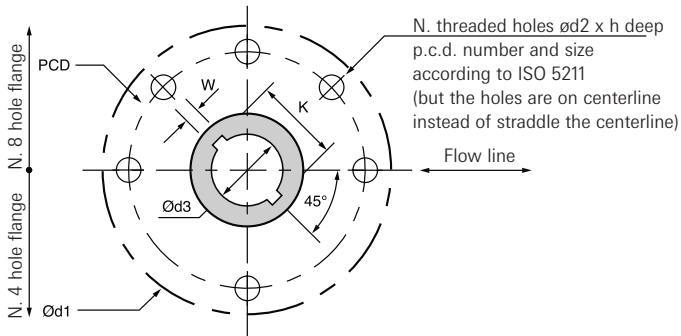

Top view of the scotch yoke mechanism  
(actuator shown in closed position)

### Actuator models 14 to 32

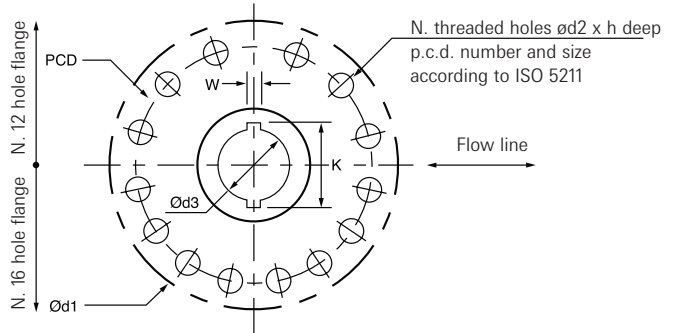

Top view of the scotch yoke mechanism  
(actuator shown in closed position)





### Coupling dimensions (mm)

Actuator Model	PCD	dia d1	dia d2	N	Standard Bore			Keyway	
					h	dia d3	Depth	W	K
0.3	165	240	M20	4	17	70	122	12	75.6
0.9	254	310	M16	8	19	86	145	14	93.6
1.5	298	360	M20	8	19	112	184	18	119
3.0	356	430	M30	8	23	157	192	25	167.8
6.0	406	520	M36	8	29	200	245	28	212.8
14	483	579	M36	12	29	175	330	45	195.8
18	603	678	M36	16	32	200	387	45	220.8
32	596	780	M36	16	32	220	387	50	242.8

### Notes

- \* Thread according to ISO R261
- Ød1 is maximum adapter flange diameter.

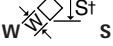
### Stem acceptance dimensions for insert bushings (mm)

Housing size	Max. stem diameter with square key (key dimension)	Max. stem diameter with rectangular key (•)	Square stem		Maximum stem protrusion**
					
0.3	52 (14)	55	46	64	120
0.9	66 (16)	70	55	77	140
1.5	85 (18)	90	73	103	180
3.0	120 (32)	130	104	147	190
6.0	150 (36)	170	133	188	240
14		Not Applicable			
18		Not Applicable			
32		Not Applicable			

### Notes

- The listed maximum acceptance values are applicable for stems with keyway parallel or perpendicular to the flow line and for square stems with diagonal parallel with the flow line.
- Key according to UNI6604 or DIN 6885 sh.1 or BS4325 part 1 or ISO 773 or equivalent.
- † S max: maximum external diameter in case of rounded edge.
- \*\*Without adapter flange.

# Alga Double Acting Pneumatic Actuator

## Scotch Yoke Design

### Notes

1. Maximum operating torque is maximum rating of scotch yoke mechanism.
2. Maximum allowable pressure is 10.5 bar (static pressure applicable to fully stroked actuator against travel stops).
3. Maximum operating pressure is the pressure required to produce the maximum operating torque of the actuator.

### Operating data

Actuator model	Air consumption (litres)	Max. operating pressure		Max. operating torque (Nm)
		Canted (bar)	Symmetric (bar)	
0.3C-135	2.9	10.5	10.5	2485
0.3C-175	4.8	7	10.5	2485
0.3C-235	9	3.5	5.5	2485
0.9C-235	9	9	10.5	6890
0.9C-280	14	6.2	9	6890
1.5C-280	16	9	10.5	11750
1.5C-335	23	6.2	8.3	11750
1.5C-385	31	4	6.2	11750
3.0C-280	47	5.5	7.6	24850
3.0C-485	74	3.5	4.8	24850
6.0C-485	85	6.2	9	49700
6.0C-585	124	4	5.5	49700
14C-635	159	6.2	9	98300
18C-685	208	7	10.5	146900
18C-735	239	5.5	9	146900
18C2-635	357	4	5.5	146900
32C2-685	487	4.8	7.6	248500

### Accessories mounting dimensions (mm)

#### Actuator

model	A	B	C	ØD	E	F	G	H	J	L	M	N	ØP	Q	R	S	T	U	V	W	X	Y
0.3	77.5	155	60	14	5	113	119	37	12	92	200	60	14	36	5	200	140	70	70	No. 4 x M10	10	10
0.9	92.5	185	60	14	5	155	170	61	35	85	200	60	14	48	5	243	140	70	70	No. 4 x M10	12	22
1.5	92.5	185	60	14	5	175	185	62	35	130	300	100	14	45	5	284	140	70	70	No. 4 x M10	12	22
3	117.5	235	85	23	8	203	215	57	25	230	500	100	14	54	5	371	160	127	136	No. 4 x M16	12	12
6	137	455	115	23	8	248	260	59	22	224	500	100	14	87	8	480	160	127	136	No. 4 x M16	13	30
14	315	630	200	27	10	227	330	97	55	220	500	170	27	99	8	543	160	127	136	No. 4 x M16	16	16
18	315	630	200	27	10	235	340	72	32	306	680	215	27	80	10	600	314	109	109	No. 4 x M16	18	35
32	315	630	200	27	10	385	395	72	32	414	890	215	27	149	10	660	314	109	109	No. 4 x M16	16	33

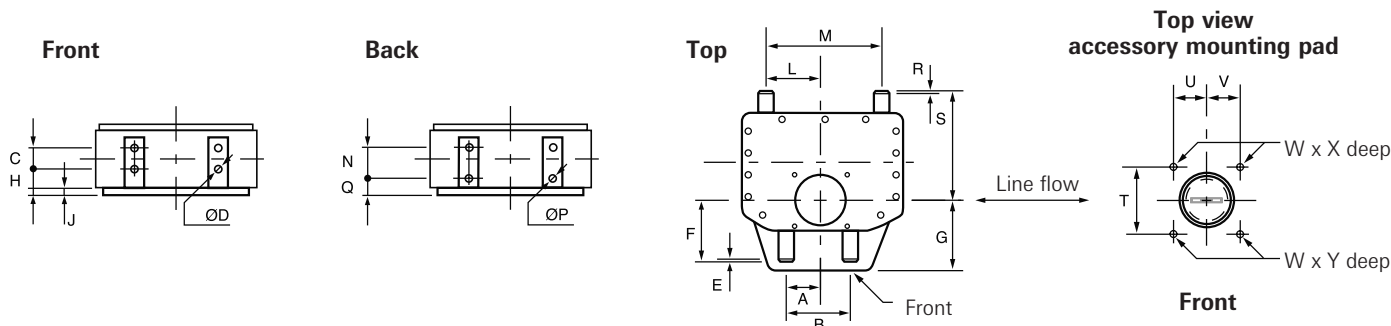

# Alga Double Acting Pneumatic Actuator

## Canted Yoke Design

### Output torques (daNm)

Model	Max operating torque (daNm)	Max operating pressure (bar g)	Angular position	Operating supply pressure (bar g)							
				3	3.5	4	5	6	7	8	9
0.3C-135	250	10	0°	60	71	82	103	124	146	167	188
			45°	23	27	31	39	47	55	63	71
			90°	31	37	43	54	65	76	87	99
0.3C-175	250	6	0°	102	120	138	174	210			
			45°	39	46	53	67	80			
			90°	54	64	73	92	111			
0.3C-235	250	3.5	0°	186	219						
			45°	72	85						
			90°	100	117						
0.9C-235	700	8	0°	216	253	290	365	440	515	590	
			45°	83	98	112	141	170	199	228	
			90°	115	135	155	196	236	276	316	
0.9C-280	700	6	0°	307	360	413	520	626			
			45°	118	138	158	199	240			
			90°	163	191	219	276	332			
1.5C-280	1200	8	0°	388	455	523	657	791	926	1060	
			45°	149	174	200	252	303	355	406	
			90°	206	242	277	349	420	491	562	
1.5C-335	1200	6	0°	558	654	750	942	1135			
			45°	215	252	289	363	437			
			90°	298	349	400	503	606			
1.5C-385	1200	4	0°	742	869	996					
			45°	287	336	385					
			90°	397	465	534					
3C-385	2500	5	0°	1230	1440	1650	2070				
			45°	475	556	638	800				
			90°	658	770	883	1110				
3C-485	2500	3.5	0°	1960	2300						
			45°	762	892						
			90°	1060	1240						
6C-485	5000	6	0°	2290	2680	3070	3850	4630			
			45°	891	1040	1190	1500	1800			
			90°	1230	1440	1650	2070	2490			
6C-585	5000	4	0°	3350	3920	4480					
			45°	1300	1520	1750					
			90°	1810	2110	2420					
14C-635	10000	6	0°	4310	5040	5770	7230	8700			
			45°	1680	1960	2240	2810	3380			
			90°	2320	2720	3110	3900	4680			
18C-685	15000	7	0°	5770	6750	7730	9680	11640	13590		
			45°	2240	2620	3000	3760	4520	5280		
			90°	3100	3630	4150	5210	6260	7310		
18C-735	15000	6	0°	6640	7770	8890	11150	13400			
			45°	2580	3020	3460	4330	5210			
			90°	3580	4180	4790	6000	7210			
18C2-635	15000	4	0°	9870	11540	13220					
			45°	3860	4520	5170					
			90°	5350	6260	7160					
32C2-685	25000	5	0°	13490	15780	18070	22640				
			45°	5280	6170	7070	8850				
			90°	7310	8550	9790	12270				

### Notes

- Max allowable pressure 10.5 bar g (static pressure applicable to fully stroked actuator against the travel stops).
- Max operating pressure is the pressure required to produce the maximum operating torque of the actuator.
- Angular positions:
  - 0° closed
  - 45° intermediate
  - 90° open.

# Alga Double Acting Pneumatic Actuator

## Symmetric Yoke Design

Output torques (daNm)												
Model	Max operating torque (daNm)	Max operating pressure (bar g)	Angular position	Operating supply pressure (bar g)								
				3	3.5	4	5	6	7	8	9	10
0.3S-135	250	10	0°	38	45	51	65	78	91	105	118	132
			45°	23	27	31	40	48	56	64	73	81
			90°	38	45	51	65	78	91	105	119	132
0.3S-175	250	10	0°	64	75	87	109	132	154	177	199	222
			45°	40	47	54	68	82	96	110	124	138
			90°	65	77	88	111	134	157	180	203	226
0.3S-235	250	5	0°	117	137	158	198					
			45°	73	86	99	125					
			90°	120	141	162	204					
0.9S-235	700	10	0°	135	159	182	229	276	323	370	417	464
			45°	85	100	114	144	173	203	232	262	292
			90°	139	163	187	236	284	332	381	429	477
0.9S-280	700	9	0°	193	226	259	326	393	459	526	593	
			45°	120	141	161	203	244	286	327	369	
			90°	196	230	264	332	400	468	536	604	
1.5S-280	1200	10	0°	264	310	356	447	539	630	722	813	905
			45°	152	178	204	257	310	362	415	467	517
			90°	227	266	306	384	463	542	620	699	777
1.5S-335	1200	9	0°	380	445	511	642	773	904	1030	1170	
			45°	218	256	294	369	444	520	598	674	
			90°	328	385	442	555	668	781	895	1010	
1.5S-385	1200	6	0°	505	591	678	851	1020				
			45°	291	341	391	491	591				
			90°	438	513	588	738	889				
3S-385	2500	8	0°	825	966	1110	1390	1670	1960	2240		
			45°	485	568	651	814	979	1150	1310		
			90°	736	863	989	1240	1490	1750	2000		
3S-485	2500	5	0°	1320	1540	1770	2220					
			45°	775	907	1040	1300					
			90°	1180	1380	1580	1990					
6S-485	5000	9	0°	1540	1800	2060	2590	3110	3630	4150	4680	
			45°	906	1060	1210	1520	1830	2140	2450	2750	
			90°	1380	1620	1850	2330	2800	3270	3740	4210	
6S-585	5000	6	0°	2250	2630	3010	3770	4530				
			45°	1330	1550	1780	2220	2670				
			90°	2030	2370	2710	3400	4090				
14S-635	10000	9	0°	2940	3430	3930	4930	5920	6920	7910	8910	
			45°	1700	1990	2280	2860	3430	4010	4590	5170	
			90°	2560	2990	3430	4290	5160	6030	6900	7770	
18S-685	15000	10	0°	3930	4590	5260	6590	7920	9250	10580	11910	13250
			45°	2280	2660	3050	3820	4590	5360	6130	6900	7670
			90°	3420	4000	4580	5740	6900	8060	9220	10380	11540
18S-735	15000	9	0°	4520	5290	6050	7590	9120	10650	12180	13720	
			45°	2620	3070	3510	4400	5290	6180	7070	7950	
			90°	3940	4610	5280	6620	7950	9290	10630	11960	
18S2-635	15000	6	0°	6720	7860	9000	11270	13550				
			45°	3920	4590	5250	6580	7910				
			90°	5900	6900	7900	9900	11900				
32S2-685	25000	7	0°	9070	10600	12140	15210	18290	21360			
			45°	5370	6280	7190	9010	10830	12650			
			90°	8190	9570	10960	13740	16510	19280			

### Notes

- Max allowable pressure 10.5 bar g (static pressure applicable to fully stroked actuator against the travel stops).
- Max operating pressure is the pressure required to produce the maximum operating torque of the actuator.
- Angular positions: 0° closed  
45° intermediate  
90° open.

## Canted and Symmetric scotch yoke torque output

ALGA actuators are available with either canted or symmetric scotch yoke mechanisms. The canted version produces a torque output as represented in Fig 1 and is therefore most suitable for use with valves which display a similar torque requirement, such as butterfly valves.

The torque output characteristics of the symmetric version are as shown in Fig 2 and are most suitable for use with valves which display a similar torque requirement, such as ball valves.

**ALGA (double acting)  
canted yoke mechanism**

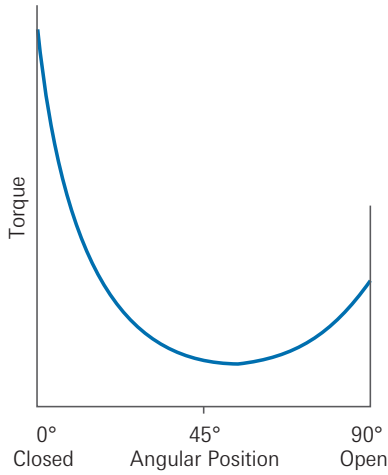

**Fig. 1**

**ALGA (double acting)  
symmetric yoke mechanism**

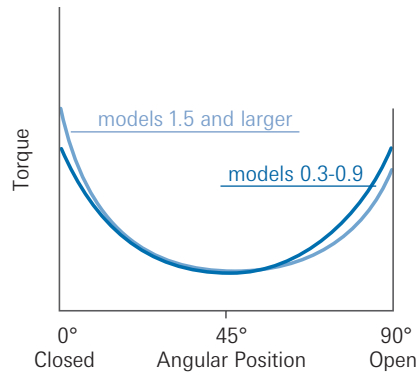

**Fig. 2**

## Other control products

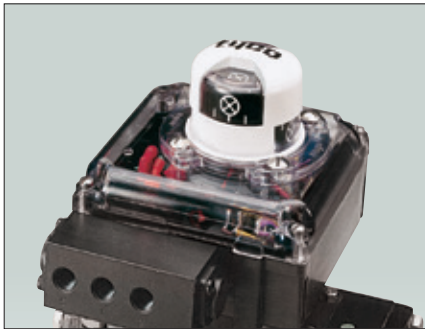

Pentair AVID Control Position Monitors



Pentair AVID analogue positioners



Pentair AVID intelligent positioners



Biffi manual override device

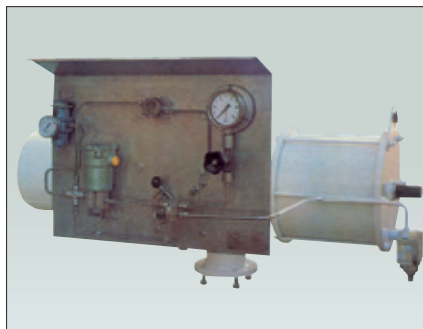

Biffi control panel