

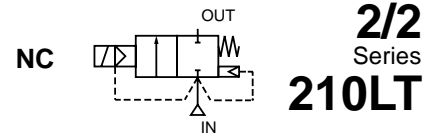

SOLENOID VALVES

normally closed, pilot operated
floating piston, for Cryogenic service
1 to 1 1/2



FEATURES

- All products are covered by the Pressure Equipment Directive 97/23/EC and are suitable for group 1 and 2 fluids
- The solenoid valves will withstand the severe service encountered in controlling cryogenic fluids, such as liquid oxygen (-183°C), liquid argon (-186°C) and liquid nitrogen (-196°C)
- Solenoid valves require a minimum pressure differential of 0,35 bar
- All valves are degreased, cleaned, tested and packed to keep them free from moisture. In addition, liquid oxygen (LOX) valves are 'black light' tested to check for any hydrocarbons
- Heavy duty floating piston design for severe applications
- The solenoid valves satisfy all relevant EC directives

GENERAL

Differential pressure 0,35 - 14 bar [1 bar = 100 kPa]
Maximum viscosity 65 cSt (mm²/s)
Response times 40 - 120 ms

fluids (*)	temperature range (TS)	seal materials (*)
cryogenic fluids	-196 to +90°C	PTFE

MATERIALS IN CONTACT WITH FLUID

(*) Ensure that the compatibility of the fluids in contact with the materials is verified

Body Brass
Core tube Stainless steel
Core and plugnut Stainless steel
Springs Stainless steel
Seat Brass
Seals PTFE and Lead-Clad Copper
Core disc PTFE reinforced
Piston Brass
Piston disc PTFE
Piston rings PTFE (carbon filled)
Shading coil Copper

ELECTRICAL CHARACTERISTICS

Coil insulation class F
Connector Spade plug (Pg 11P)
Connector specification ISO 4400
Electrical safety IEC 335
Standard voltages DC (=) : contact us
 (Other voltages and 60 Hz on request) AC (~) : 24V - 115V - 230V / 50 Hz

coil type	power ratings				ambient temperature range (TS) (°C)	protection
	inrush	holding		=		
	~ (VA)	~ (VA)	(W)	(W)		
CMXX-FB	78	35,0	16,7	-	-20 to +50	moulded IP65

SPECIFICATIONS

pipe size	orifice size (mm)	flow coefficient Kv (m ³ /h) (l/min)		operating pressure differential (bar)		coil type	catalogue number
				min.	maximum (PS)		
					cryogenic fluids (*)		
NPT					~	~	
1	25	11,6	193	0,35	14	CMXX-FB	SCB210C078LT
1 1/4	28	12,8	213	0,35	14	CMXX-FB	SCB210C080LT
1 1/2	32	19,3	321	0,35	14	CMXX-FB	SCB210C082LT

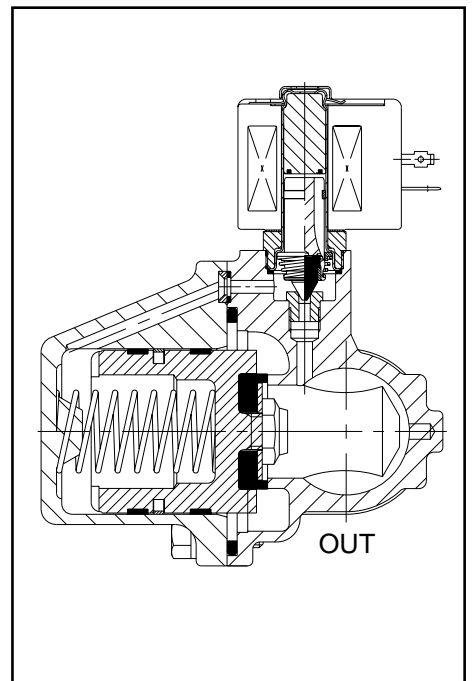

OPTIONS

- Waterproof enclosure with embedded screw terminal coil and Pg 13,5 cable gland to meet CEE-10 (IP67)
- Explosionproof enclosures for hazardous locations according to "GENELEC" and national standards (see section 10)
- Explosionproof and watertight enclosures according to "NEMA" standards (see section 10)
- Compliance with "UL" and "CSA" standards
- Manual operator
- Plug with visual indication and peak voltage suppression (see section 11)

INSTALLATION

- The valves can be mounted in any position without affecting operation
- Pipe connection identifier is: B= NPT (ANSI 1.20.3)
- The third digit in the catalogue number indicates the standard pipe connection
- Other pipe connections are available on request
- Installation/maintenance instructions are included with each valve
- Spare Parts Kit and replacement coils are available (see section 11)

DIMENSIONS (mm), WEIGHT (kg)

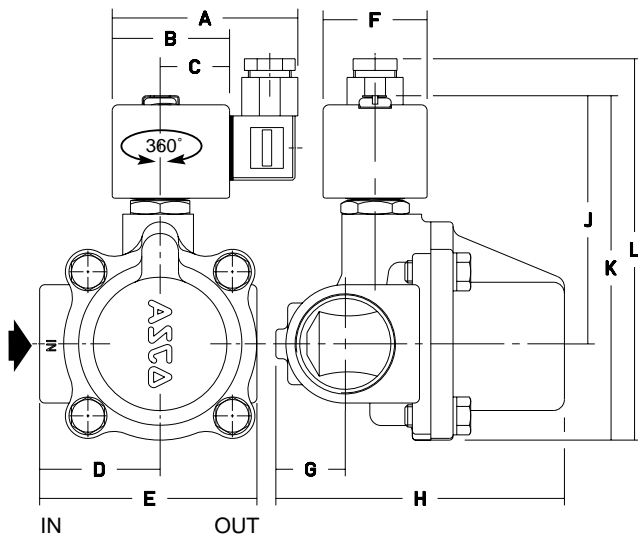

catalogue number SCB210	A	B	C	D	E	F	G	H	J	K	L	weight (1)
C078LT	80	50	30	52	95	45	20	108	108	147	166	2,5
C080LT	80	50	30	52	95	45	33	119	108	147	166	3,0
C082LT	80	50	30	52	111	45	33	142	112	160	179	5,0

(1) incl. coil and connector