

FEATURES

- High flow due to angled seat design
- Anti-waterhammer design (fluid entry under the disc)
- Actuator rotatable through 360°
- Maintained valve position in case of power failure
- Fluid isolation between electrical actuator and valve body
- LED valves status display
- The valves satisfy Pressure Equipment Directive 97/23/EC, article 3.3
- The motorised valves comply with the essential requirements of EMC Directive 2004/108/EC (EN-IEC 61000-6-2 et EN-IEC 61000-6-4) and Low Voltage Directive 2006/95/EC (EN-IEC 60730)

GENERAL

Differential pressure	See «SPECIFICATIONS» [1 bar =100 kPa]
Maximum allowable pressure	10 bar
Ambient temperature range	-10°C to +50°C
Maximum viscosity	600 cSt (mm ² /s)
Actuating time	< 1 s (opening) / < 1 s (closing)

fluids (*)	temperature range (TS)	seal materials (*)
air and gas groups 1 & 2 water, oil, liquids groups 1 & 2	-10°C to +90°C	NBR (nitrile)

CONSTRUCTION

MATERIALS IN CONTACT WITH FLUID	
(*) Ensure that the compatibility of the fluids in contact with the materials is verified	
Valve body	AISI 316L
Stuffing box housing	PBT, GF 30% (glass fibre reinforced)
Stem valve	Stainless steel, AISI 303
Stuffing box packing	NBR
Wiper seal	NBR
Disc seal	NBR

OTHER MATERIALS

Top cover operator	Translucent polyamide (PA)
AC to DC housing (AC)	PA66, GF 30% (ball fibre reinforced)

ELECTRICAL CHARACTERISTICS

Connector	Spade plug (cable Ø 6-10 mm)
Connector specification	ISO 4400 / EN 175301-803, form A
Motor consumption	12 W in operation, 0 W hold Max. peak current: 0,7 A
Visualisation valve (switching)	LED
Electrical safety (adapter AC to DC)	IEC 335 (EN-IEC 60730), class 2
Electrical enclosure protection	IP65 (EN 60529)
Standard voltages	DC (=) : 24V ±10 %, max. ripple 5% (EN-IEC 61131-2) AC (~) : 110V to 250V / 50-60 Hz ⁽¹⁾

RECOMMENDATION FOR MAXIMUM DUTY CYCLE

Ambient temperature +20°C	9 cycles/min ⁽²⁾
Ambient temperature +50°C (max.)	4 cycles/min ⁽²⁾

ACCESSORIES

AC to DC adapter: 110V to 250V/50-60 Hz
code: P290CA430078001
24V to 48V /50-60 Hz ±10 % (contact us)
code: P290CA430078002

OPTIONS (contact us)

Valve body/stem 316L and FPM (fluoroelastomer) disc seal (*)
M12 connector adapter
Fail closed (close on loss of power)

(*) Ensure that the compatibility of the fluids in contact with the materials is verified.

⁽¹⁾ 24 V to 48 V AC /50-60 Hz, contact us.

⁽²⁾ For other cycles, contact us.

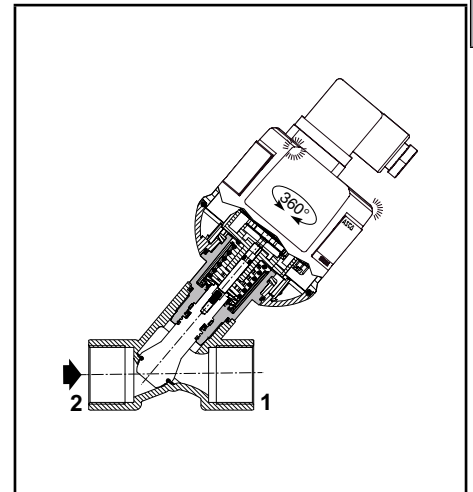

DC construction

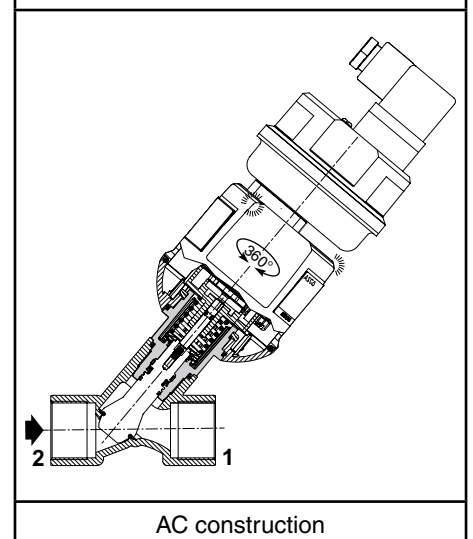

AC construction

D

SPECIFICATIONS

piping (ISO 6708)		flow coefficient Kv		operating pressure differential (bar)		operator diameter (mm)	thread type	dimensions / type (1)	15-DIGIT PRODUCT CODE					
pipe size	DN	(m ³ /h)	(l/min)	min.	max. air, water, oil (*)				stainless steel AISI 316L	voltage code				
Motorized valve, entry under the disc														
3/8	10	2,7	45	0	6	67	G*	1	E290C52V0KA00					
1/2	15	3,8	63	0	5	67	G*	1	E290C53V0KA00			VQ	VW	V1
3/4	20	6	100	0	4	67	G*	1	E290C54V0KA00					

(1) For dimensions, see drawing(s) for each construction type on the following page(s).

(2) Contact us.

(*) Ensure that the compatibility of the fluids in contact with the materials is verified.

15-DIGIT PRODUCT CODE

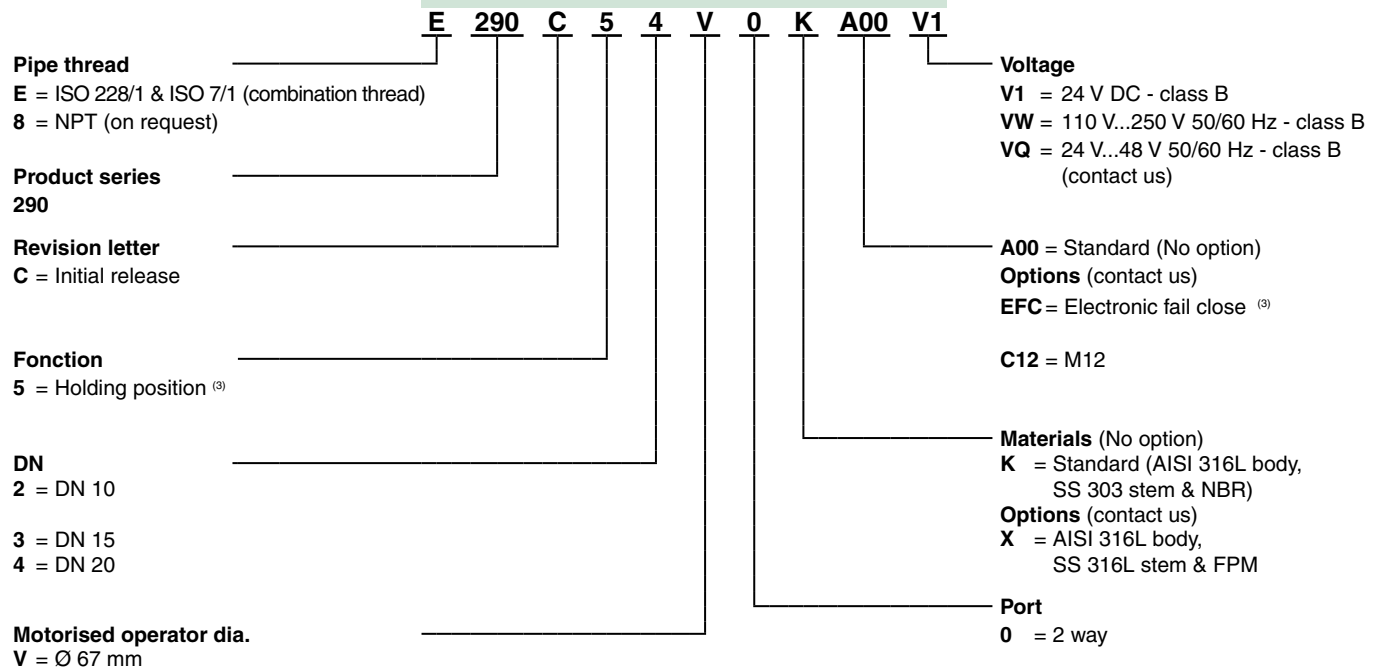

(3) Use with EFC option (Electronic fail close)

INSTALLATION

- The valves can be mounted in any position without affecting operation
- Pipe connections (G*) have standard combination thread according to ISO 228/1 and ISO 7/1
- Other pipe connections are available on request
- Installation/maintenance instructions are included with each valve
- 2D/3D CAD models - [In 3D](#)
- LED indicators for operating status display

status	indicator
valve OPEN	green
valve CLOSED	orange
valve moves to open	green flashing
valve moves to close	orange flashing

OPERATING DIAGRAM

standard (holding position)

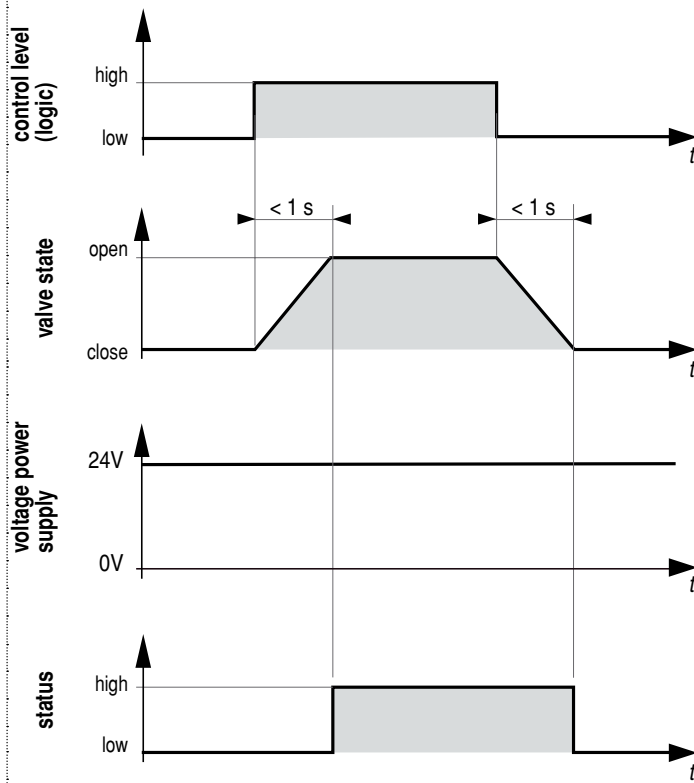

WIRING DC

24 V / DC



1	24 V / DC
2	0 V
3	control
4	state return (valve to PLC)

With PLC

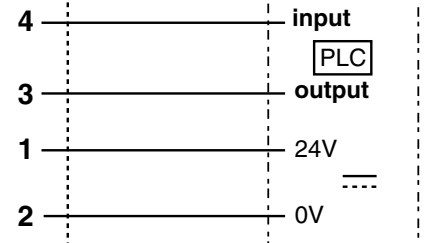

Without PLC

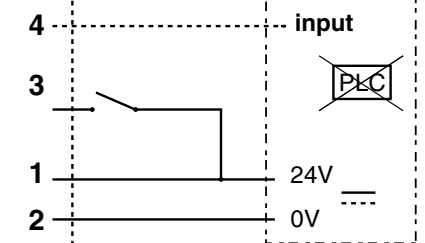

WIRING AC

24 V...48 V / AC 50/60 Hz ⁽¹⁾

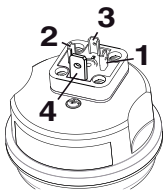

1	phase (Ph)
2	neutral (N)
3	control
4	state return (valve to PLC)

With PLC

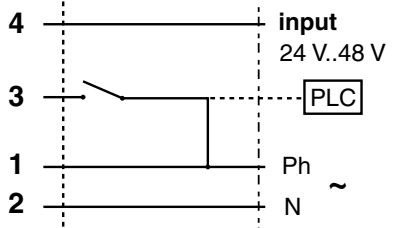

Without PLC

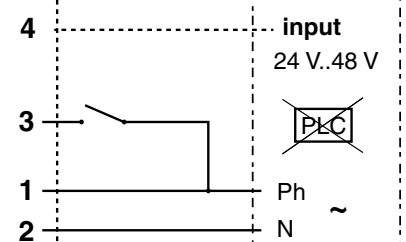

110 V...250 V / AC 50/60 Hz

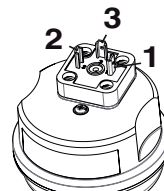

1	phase (Ph)
2	neutral (N)
3	control
-	-

With PLC

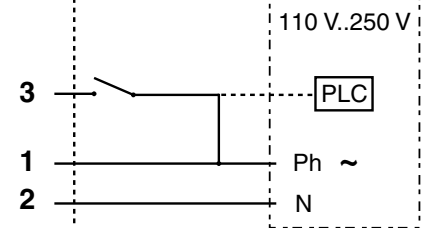

Without PLC

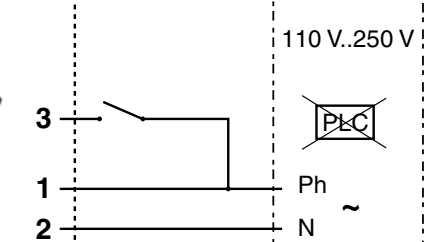

⁽¹⁾ Contact us.

DIMENSIONS (mm), WEIGHT (kg)



TYPE 01

DC version
67 mm motorised operator
Fluid entry: under the disc at 2
ISO 4400 connector

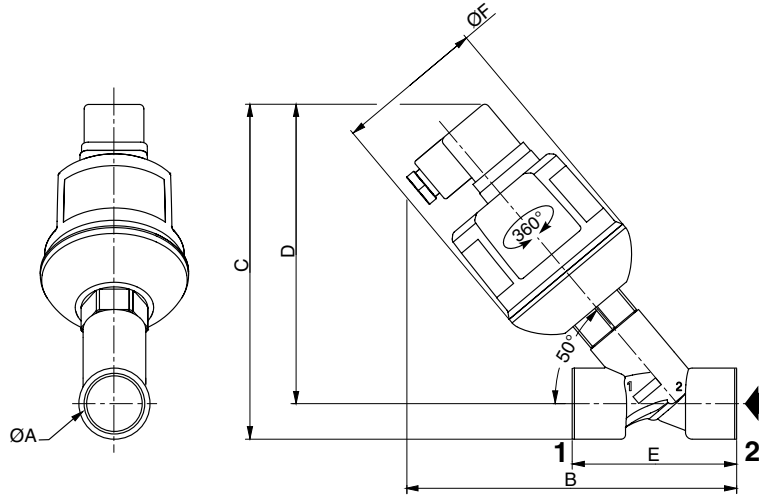

TYPE 02

AC version (accessories)
67 mm motorised operator with AC adapter
Fluid entry: under the disc at 2
ISO 4400 connector

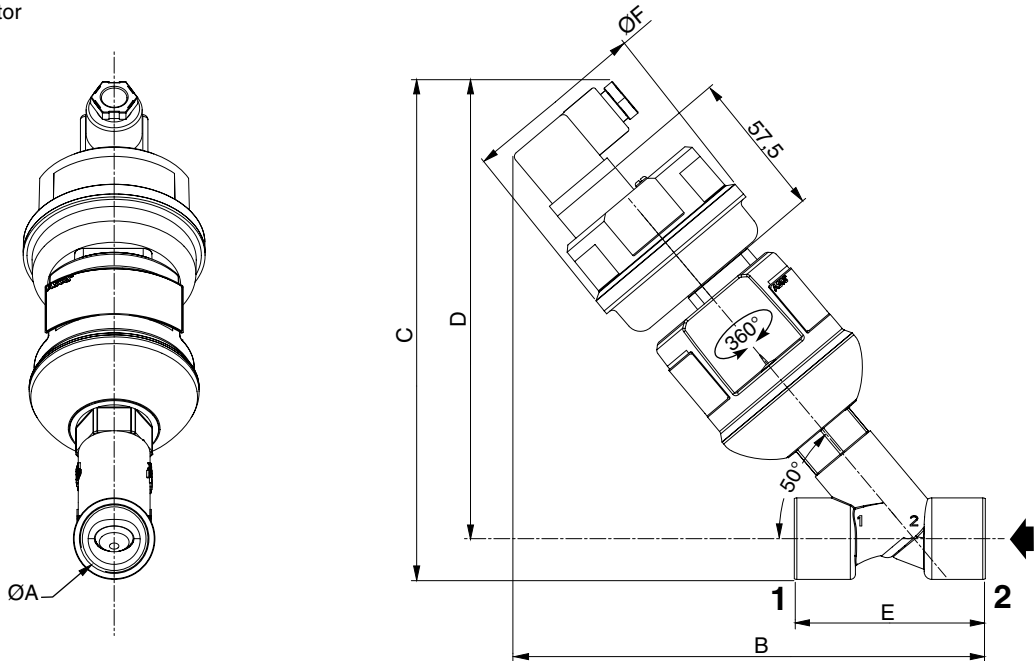

type	$\varnothing A$	B	C	D	E	$\varnothing F$	weight ⁽¹⁾
DC version							
01	3/8	135	141	129	55	67	0,55
	1/2	142	145	131	65	67	0,55
	3/4	150	152	136	75	67	0,55
AC version							
02	3/8	171	189	175	55	71	0,65
	1/2	178	191	177	65	71	0,65
	3/4	186	196	180	75	71	0,65

⁽¹⁾ Incl. connector.