

CV-8450 & CV-8750

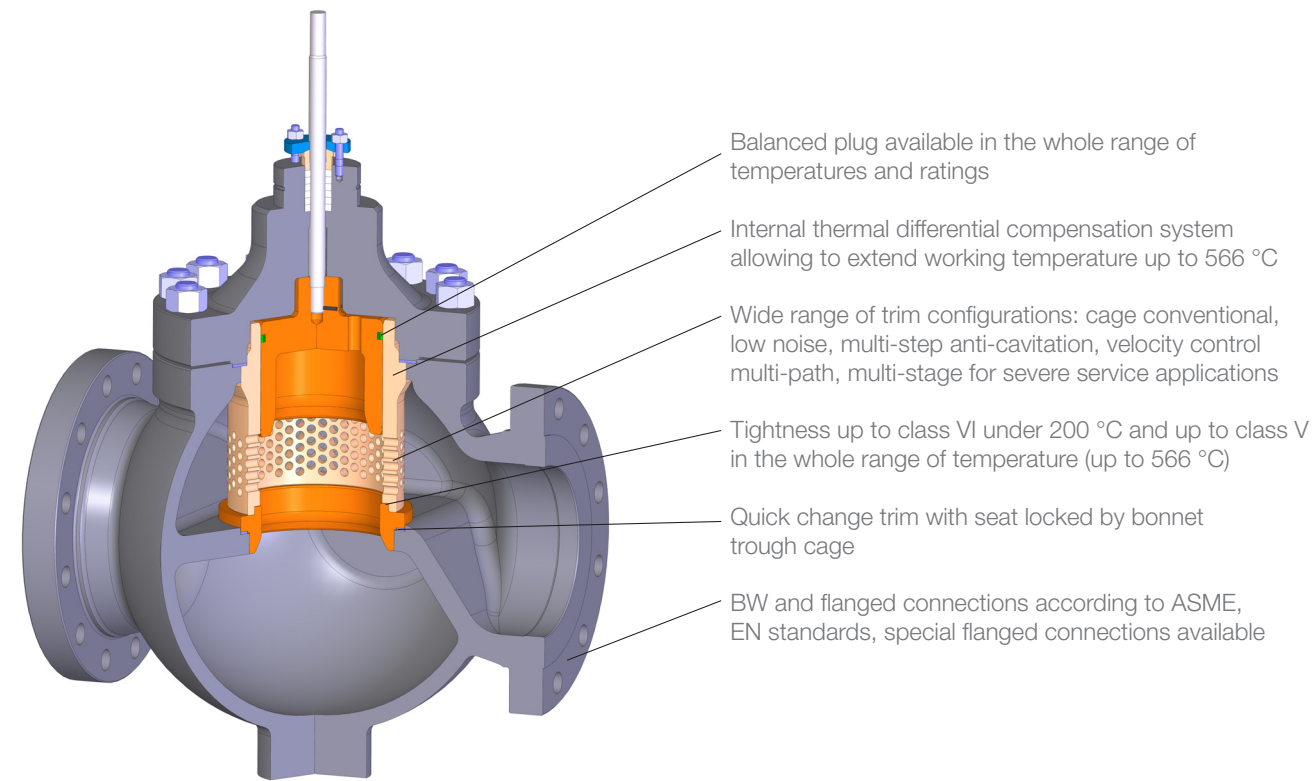

Multi cage anti cavitation trim

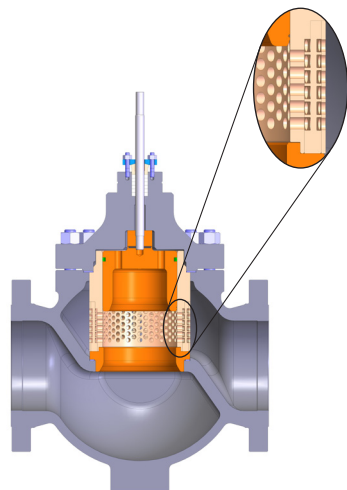

AC-DC / AC-TC
Double or Triple Cage Anti Cavitation, high recovery trim is available for high pressure drop or when anti-cavitation trim is required

Multipath – Multistage labyrinth trim for severe service applications

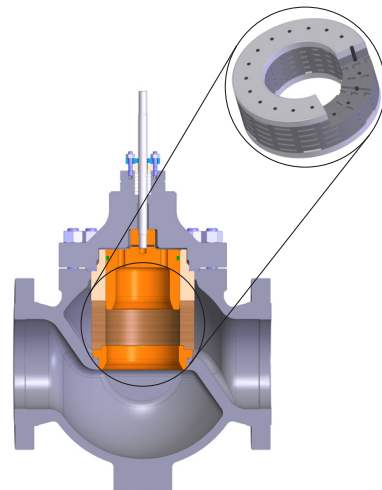

AST VeCo-LT
Velocity Controlled Labyrinth Trim, is a multi-path, multi-stage labyrinth trim specially designed for anti-cavitation, low noise and anti-erosion service.

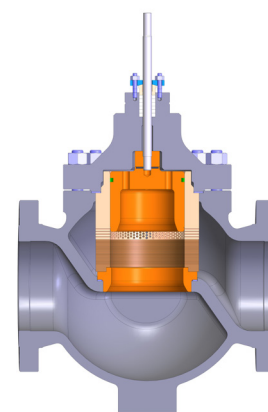

AST Vary-VeCo
Variable recovery factor trim, combines VeCo-LT and conventional cage to avoid cavitation at low opening minimizing pressure drop at full opening.

CV-8450 & CV-8750

Plug Balancing available solutions

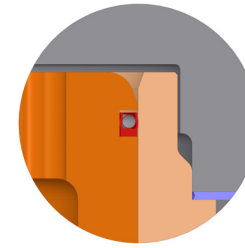

PTFE carbon-graphite loaded lip seal
up to **class VI**
T max 315 °C

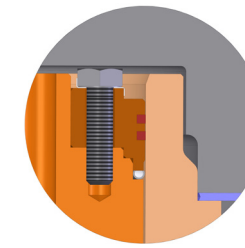

Metal C-Ring
up to **class V**
No temperature limitations

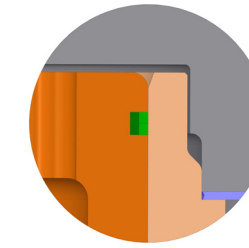

Carbon-graphite rings
up to **class IVS1**
No temperature limitations

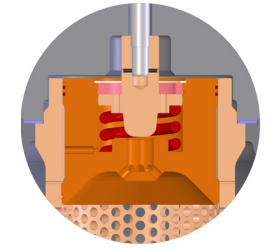

Balanced trim with pilot plug
class **V and over**
No temperature limitations

Main features

Specially designed for critical service applications, where higher performances than conventional contoured plug, screwed seat valves are required, CV-8450 (straight way body) & CV-8750 (angle body) series valves feature a cage based robust, simple and reliable design with a wide range of anti-noise, anti-cavitation and velocity-controlling trims for heavy-duty applications.

All valves have quick change design with seat locked by the drilled cage also guiding the plug for the whole stroke, realizing flow control and allowing plug balancing to reduce actuating forces.

The trim design, with internal thermal differential compensation system, allows to extend working temperatures from -55 °C (-196 °C for the cryogenic series) up to 566 °C.

A large number of plug balancing solutions allows to reach highest sealing classes in the whole range of operating temperature with reduced actuating forces.

Standard, low noise, single and multi-cage trims in the flow capacity range from rated Cv 0.05 to over 6000 with equal-percentage or linear flow characteristic, allow to withstand most process solution by avoiding noise, cavitation and erosion.

Special designed VeCo-LT multi-path, multi-step Labyrinth Trim is available for most critical application on gas and liquid service.

Balanced trim with pilot plug is also available for high temperature compressible fluid service applications, likewise atmospheric vents, where zero leakage is required.

For service on compressible fluids with high differential pressures or in presence of evaporating fluids (flashing), special solutions with fixed orifices installed downstream the valve for a full velocity control can be supplied.

Materials: Wide range of material configurations are available: Carbon steel (WCC/LCB, A105/LF2), Cr-Mo steels (WC9/C12A, F22/F91), Stainless Steel, Duplex and Super Duplex Steels (S32760, S32550, HVD1), S31050, Nickel Alloys. Other materials upon request.

Actuators: pneumatic actuators with electro-pneumatic or digital positioners, mechanical or hydraulic side or top mounted hand-wheels. Electric or electro hydraulic actuators upon request.

Accessories: bellows for perfect tightness on the stem.

Sizes / Pressure Classes

Size from DN ½" to DN 24"
Rating: up to Class 2500.

Design Codes & Product Standards

IEC 60534, FCI 70-2, EN 12516, EN 1092, ASME B16.34, ASME B16.5.

Approvals/Qualifications

CE marking 2014/68/UE CE PED and 2014/34/UE CE ATEX, CU-TR (Russia, Belarus, Kazakhstan, Armenia, Kyrgyzstan).