

HUMIDITY SEPARATORS S25/S HV and VH PN16 – PN40

DESCRIPTION

S-25 HV and VH series centrifugal separators remove moisture from steam and compressed air pipelines. Steam and compressed air passing through the separator and as a result of centrifugal forces, impact and swirling effects, separate the particles with a heavier specific gravity, such as water and oil droplets, moisture in suspension, dirt and scale.

The condensate collected at the bottom of the separator, must be automatically drained by a suitable steam or compressed air trap.

Connections are flanged.

MAIN FEATURES

Several possibilities of installation.

No moving parts.

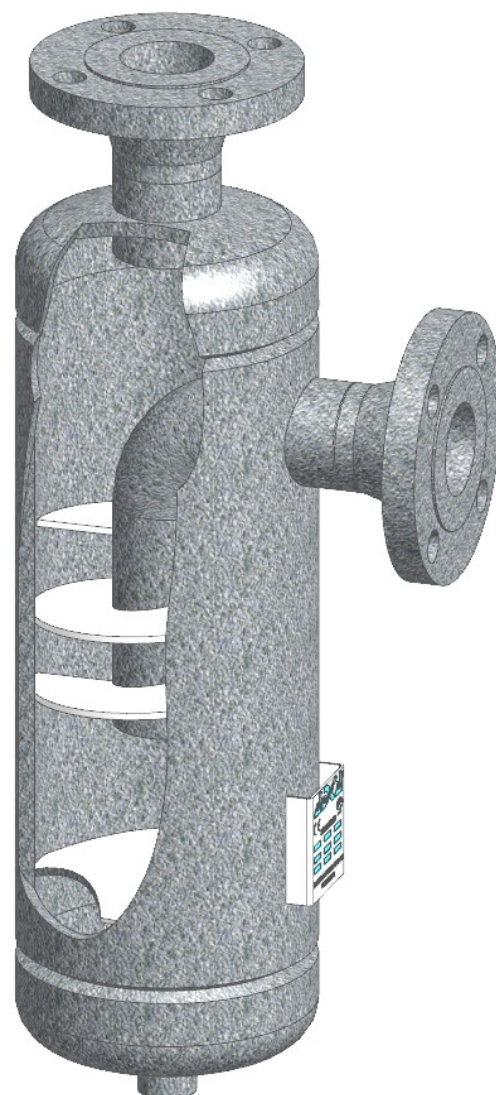

OPTIONS:

Zinc plated fabricated carbon steel construction (compressed air)
Condensate flanged connection.

USE:

Steam, compressed air and other gases (Group 2).

AVAILABLE MODELS:

S25/S HV or VH - carbon steel body.
S25/SZ HV or VH - zinc plated body

SIZES:

DN15 to DN200.

PIPE CONNECTIONS:

Flanged EN1092-1 PN16 and PN40
ANSI Class 150 lbs and Class 300 lbs
Female screwed BSP or NPT on request.

INSTALLATION:

Always with the condensate discharge pointing downwards.
See IMI, installation and maintenance instructions.

HOW TO SELECT:

Generally, in an existing plant it is advisable to fit a separator of the same size of the pipe line. Pressure drop is normally negligible. For approximate pressure drop calculation please consult.



LIMITING CONDITIONS **											
Rating	Press. bar	Temp. °C	Rating	Press. bar	Temp. °C	Rating	Press. bar	Temp. °C	Rating	Press. bar	Temp. °C
PN16	16	50	ANSI Cl.150 lbs	16	50	PN25 ANSI CL.300lbs	25	50	PN40 ANSI CL.300lbs	40	50
	14	100		14	100		23	100		37	100
	13 *	195		13 *	195		20 *	216		31 *	239
	12	250		-	-		17	300		27	300

*PMO-Max.operating pressure for saturated steam. Minimum operating temp.: -10°C. Design code: AD-Merkblatt

** Rating according to EN1092:2007.

CE MARKING - GROUP 2 GASES CATEGORIES								
RATING	SIZE	CAT.	RATING	SIZE	CAT.	RATING	SIZE	CAT.
PN16	DN15 to DN25	SEP	PN25	DN15	SEP	PN40	DN15 to DN32	1
	DN32 to DN50	1		DN20 to DN40	1		DN40 to DN80	2
	DN65 to DN125	2		DN50 to DN100	2		DN100 to DN150	3
	DN150 to DN200	3		DN125 to DN150	3		DN200	4

CE Marking

This product have been designed for use on water steam, air and other gases which are in Group 2 of the PED-European Pressure Equipment Directive 97/23/EC and it comply with those requirements. The product carries the CE mark when falling in category 1 and above.

APPROXIMATE DIMENSIONS (mm)													
FLANGED EN 1092-1 - ANSI													
SIZE DN	J PN16	J PN25	J PN40	J 150lbs	J 300lbs	B	C	D	E	H	F	VOL. * dm3	WGT ** Kg
15	115	115	115	125	130	114	260	190	70	140	1/2"	2	5
20	115	115	115	128	132	114	260	185	75	147	1/2"	2,5	6
25	115	115	115	131	137	114	300	200	100	157	1/2"	3	7
32	130	130	130	145	153	140	395	285	110	188	1/2"	5	12
40	130	130	130	147	154	140	435	325	110	195	1/2"	5,7	13,8
50	155	155	155	170	177	168	505	385	120	207	1/2"	10,5	19,5
65	190	197	197	215	221	219	550	410	140	261	3/4"	18,5	32
80	200	208	208	220	230	219	610	462	148	295	3/4"	25	38
100	243	255	255	267	277	273	715	528	187	345	3/4"	35,4	57
125	268	280	280	303	311	324	845	630	215	435	1"	50	81,5
150	293	303	303	318	326	356	962	692	270	475	1"	75	153
200	303	320	329	343	352	406	1170	880	290	500	1"	140	195

* Volume correspond to the class PN16 design.Classes PN25 and above may have slightly lower volumes.

** Weight correspond to the class PN16 design.

F-screwed drain connection as standard.Alternatively can be supplied flanged EN1092-1 or ANSI on the same class of main dimensions.

Consult factory for certified dimensions. Dimensions subject to change without notice.

MATERIALS		FLANGE CONNECTIONS			
DESIGNATION	MATERIAL	Rating	Sep. SIZE	EN STD.	ANSI STD.
Body	EN10216-2 / P235GH / 1.0325	PN16	* DN15 to DN50	EN1092-1 PN40	ANSI B16.5 Cl.150 lbs
Heads	EN10028-2 / P265GH / 1.0425	PN16	DN65 to DN300	EN1092-1 PN16	ANSI B16.5 Cl.150 lbs
Inlet / Outlet pipes	EN10216-2 / P235GH / 1.0325	PN25	DN15 to DN150	EN1092-1 PN40	ANSI B16.5 Cl.300 lbs
EN flanges	EN10222-2 / P250GH / 1.0460	PN25	DN200 to DN300	EN1092-1 PN25	ANSI B16.5 Cl.300 lbs
ANSI flanges	ASTM A105 / 1.0432	PN40	DN15 to DN300	EN1092-1 PN40	ANSI B16.5 Cl.300 lbs
Sockets	ASTM A105 / 1.0432				
Internals	EN10025-2 / S235JR / 1.0038				

* Flanges EN1092-1 PN16 and PN40 from DN15 to DN50 has the same number and size of holes.

EN10204 3.1 certificate available if requested with the order.

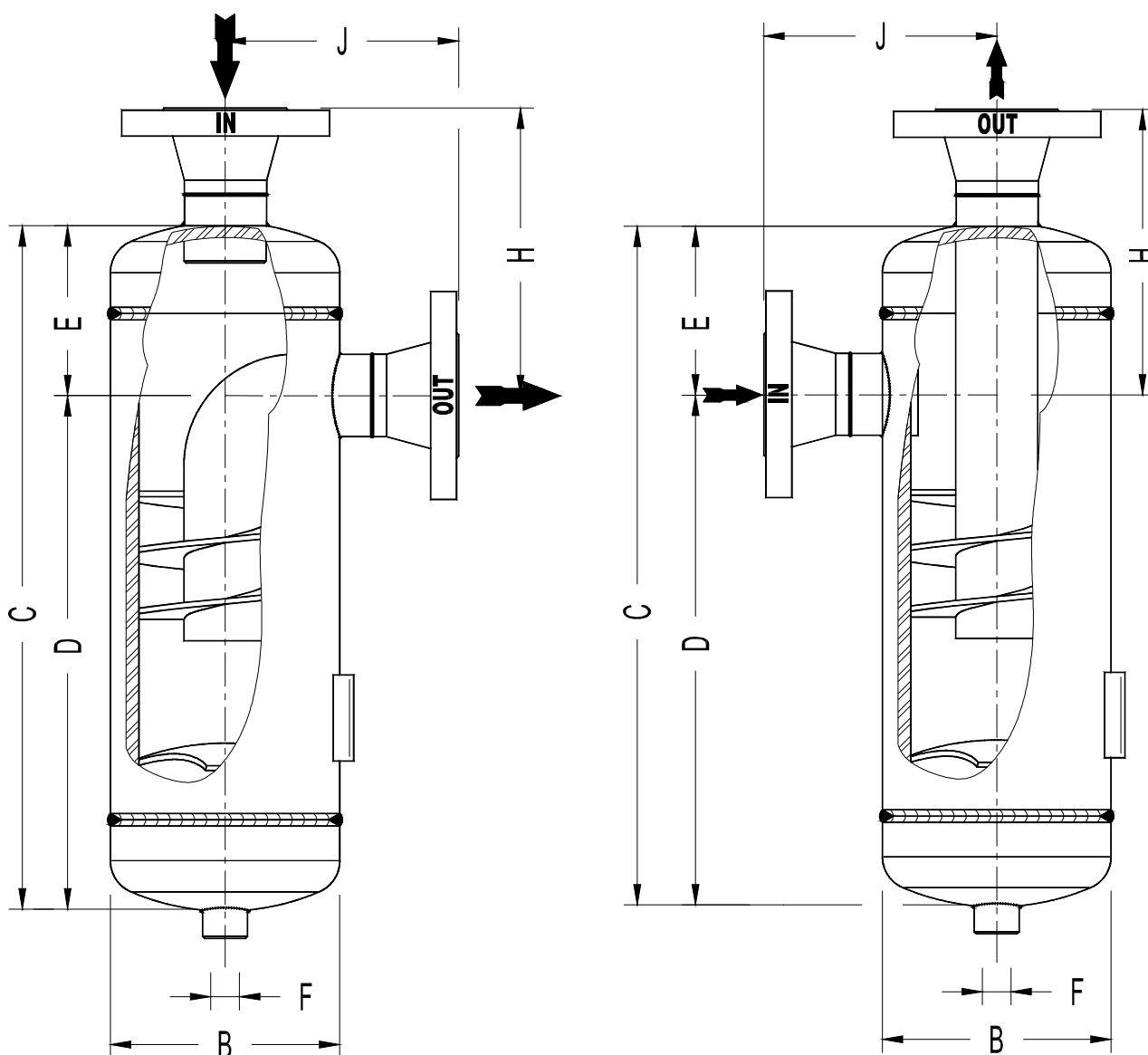

VH - Direct vertical inlet / Horizontal outlet

HV – Direct horizontal inlet / Vertical outlet