

HUMIDITY SEPARATORS SH 25 PN16 – PN40

DESCRIPTION

SH-25 series horizontal centrifugal separators remove moisture from steam and compressed air pipelines. Steam and compressed air passing through the separator and as a result of centrifugal forces, impact and swirling effects, separate the particles with a heavier specific gravity, such as water and oil droplets, moisture in suspension, dirt and scale.

The condensate collected at the bottom of the separator, must be automatically drained by a suitable steam or compressed air trap.

Connections are threaded or flanged.

MAIN FEATURES

In-line design
No moving parts.

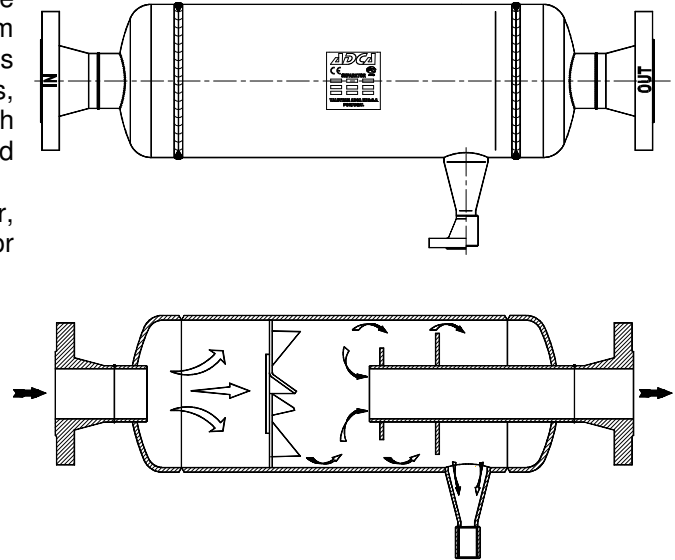

- OPTIONS:** Condensate flanged connection.
- USE:** Steam, compressed air and other gases (Group 2).
- AVAILABLE MODELS:** SH25/S - carbon steel body.
- SIZES:** DN15 to DN100.
- PIPE CONNECTIONS:** Flanged EN1092-1 PN16 and PN40
ANSI Class 150 lbs and Class 300 lbs
Female screwed BSP or NPT on request.
- INSTALLATION:** Always with the condensate discharge pointing downwards.
See IMI, installation and maintenance instructions.
- HOW TO SELECT:** Generally, in an existing plant it is advisable to fit a separator of the same size of the pipe line. Pressure drop is normally negligible. For approximate pressure drop calculation please consult.



LIMITING CONDITIONS **											
Rating	Press. bar	Temp. °C	Rating	Press. bar	Temp. °C	Rating	Press. bar	Temp. °C	Rating	Press. bar	Temp. °C
PN16	16	50	ANSI Cl.150 lbs	16	50	PN25 ANSI CL.300lbs	25	50	PN40 ANSI CL.300lbs	40	50
	14	100		14	100		23	100		37	100
	13 *	195		13 *	195		20 *	216		31 *	239
	12	250		-	-		17	300		27	300

*PMO-Max.operating pressure for saturated steam. Minimum operating temp.: -10°C. Design code: AD-Merkblatt

** Rating according to EN1092:2007.

CE MARKING - GROUP 2 GASES CATEGORIES								
RATING	SIZE	CAT.	RATING	SIZE	CAT.	RATING	SIZE	CAT.
PN16	DN15 to DN25	SEP	PN25	--	SEP	PN40	DN15 to DN32	1
	DN32 to DN50	1		DN15 to DN40	1		DN40 to DN80	2
	DN65 to DN100	2		DN50 to DN100	2		DN100	3

CE Marking

This product have been designed for use on water steam, air and other gases which are in Group 2 of the PED-European Pressure Equipment Directive 97/23/EC and it comply with those requirements. The product carries the CE mark when falling in category 1 and above.

APPROXIMATE DIMENSIONS (mm)													
FLANGED EN1092-1 - ANSI												THREADED	
SIZE DN	A PN16	A PN25	A PN40	A 150lbs	A 300lbs	B	E	F	G	VOL. * dm3	WGT ** Kg	C	WGT ** Kg
15	365	365	365	384	394	114	136	1/2"	115	2,1	4,1	357	2,7
20	370	370	370	395	404	114	138	1/2"	115	2,2	4,8	362	2,8
25	390	390	390	421	434	114	138	1/2"	115	2,4	5,2	396	2,9
32	475	475	475	505	521	140	148	1/2"	130	4,6	8	487	4,6
40	515	515	515	549	562	140	152	1/2"	130	5,1	9	521	4,7
50	590	590	590	621	634	168	166	1/2"	143	8,7	11,6	606	6,5
65	656	670	670	706	718	219	196	3/4"	180	16,3	20,4	--	--
80	724	740	740	764	783	219	200	3/4"	180	18,6	21,7	--	--
100	824	850	850	872	891	273	217	3/4"	207	28,5	31	--	--

* Volume correspond to the class PN16 design. Classes PN25 and above may have slightly lower volumes.

** Weight correspond to the class PN16 design.

F-screwed drain connection as standard. Alternatively can be supplied flanged EN1092-1 or ANSI on the same class of main dimensions.

Consult factory for certified dimensions. Dimensions subject to change without notice.

MATERIALS		FLANGE CONNECTIONS			
DESIGNATION	MATERIAL	Rating	Sep. SIZE	EN STD.	ANSI STD.
Body	EN10216-2 / P235GH / 1.0325	PN16	* DN15 to DN50	EN1092-1 PN40	ANSI B16.5 Cl.150 lbs
Heads	EN10028-2 / P265GH / 1.0425	PN16	DN65 to DN100	EN1092-1 PN16	ANSI B16.5 Cl.150 lbs
Inlet / Outlet pipes	EN10216-2 / P235GH / 1.0325	PN25	DN15 to DN100	EN1092-1 PN40	ANSI B16.5 Cl.300 lbs
EN flanges	EN10222-2 / P250GH / 1.0460	PN40	DN15 to DN100	EN1092-1 PN40	ANSI B16.5 Cl.300 lbs
ANSI flanges	ASTM A105 / 1.0432	* Flanges EN 1092-1 PN16 and PN40 from DN15 to DN50 has the same number and size of holes.			
Sockets	ASTM A105 / 1.0432				
Internals	EN10025-2 / S235JR / 1.0038				

EN10204 3.1 certificate available if requested with the order.

