

# Pressure Control Valves

## Backpressure Regulators UV 1.9



Pump Protection Valve

### Technical Data

Connection DN	50
Connection G	2
Nominal Pressure PN	16
Inlet Pressure	2 - 16
K <sub>vs</sub> -Value	12 m <sup>3</sup> /h
Temperature	130 °C
Medium	liquids

### Description

Medium-controlled overflow valves are simple control valves used to relieve pressurised systems of excessive pressure in a controlled way. These valves do not require pneumatic or electrical control components to work reliably. They are easy to install and maintain.

The UV1.9 overflow valve is a seat-controlled spring-loaded valve used to protect pump systems or other pressurised vessels or pipelines. The set pressure is continuously adjustable from the outside.

Its special feature is its very compact design. The valve cone has a hard seal (metallic seal). The valve is manufactured from deep-drawn CrNiMo stainless steel featuring excellent corrosion resistance.

Thanks to its angled form the valve drains automatically, ensuring that medium cannot freeze in the valve (Frost protection without special draining).

Pilot lines are not required.

These valves are no shut-off elements ensuring a tight closing of the valve. In accordance with the VDI/VDE guideline 2174 a leakage rate of 0.05 percent of the constant volume flow is permitted for the valve in closed position.

### Standard

- » all stainless steel construction
- » valve body manufactured from high performance deepdrawn materials
- » seat-controlled
- » angled design, no dead pockets, self-draining
- » preset at the factory
- » tamper-proof

### Capabilities

- » as pump protection valve
- » as pressure surge limiter

Operating instructions, know how and safety instructions must be observed. All the pressure has always been indicated as overpressure. We reserve the right to alter technical specifications without notice.



### Setting Ranges [bar], Nominal Pressure

2 - 5	4 - 10	8 - 16
PN 10	PN 16	PN 16

# Pressure Control Valves

## Backpressure Regulators UV 1.9



Pump Protection Valve

Materials	
Temperature	130 °C
Body	CrNiMo-steel
Spring	CrNiMo-steel
Main Valve	metallic
Valve Seal	
Elastomeres	EPDM optional PTFE or FPM

Dimensions [mm]	
size	nominal diameter DN
	50
A	125
B	125
C	224
D	190

Weights [kg]	
nominal diameter DN	
	50
	10

Special designs on request.  
 The pressure has always been indicated as overpressure.  
 Mankenberg reserves the right to alter or improve the designs or specifications of the products described herein without notice.

### Dimensional Drawing

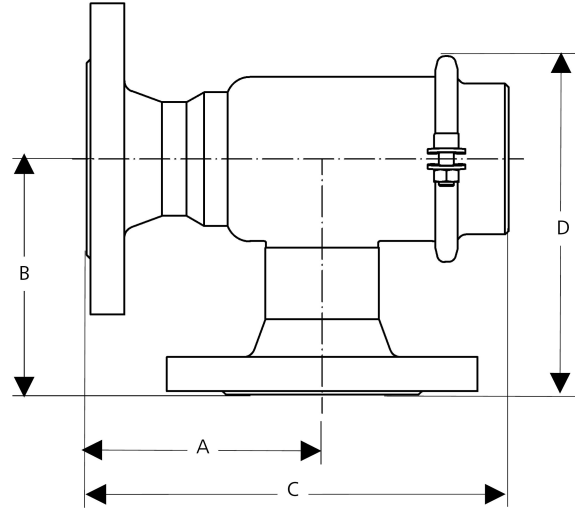

### Recommended Installation

