

Pressure Control Valves

Backpressure Regulators UV 4.4

Epoxy-coated Cast Valve for medium Flow Rates



Technical Data

Connection DN	50 - 150
Nominal Pressure PN	16, 25, 40
Inlet Pressure	max. 12 bar
K _{vs} -Value	17 - 155 m ³ /h
Temperature	70 °C
Medium	water

Description

Medium-controlled overflow valves are simple control valves offering accurate control while being easy to install and maintain. They control the pressure upstream of the valve without requiring pneumatic or electrical control elements.

The UV 4.4 overflow valve is a piston-controlled, spring-loaded proportional regulator with relief for large throughputs. The valve housing is made of spheroidal graphite iron with a continuous epoxy coating while the valve cone is soft-sealed.

The inlet pressure to be controlled is balanced across the valve seat by the force of the valve spring (set pressure). If the inlet pressure rises above the set pressure, the valve opens. With decreasing inlet pressure the valve control orifice reduces, when the pipeline is depressurised the valve is closed. Rotating the adjusting screw clockwise increases the inlet pressure.

These valves are no shut-off elements ensuring a tight closing of the valve. In accordance with the VDI/VDE guideline 2174 a leakage rate of 0.05 percent of the constant volume flow is permitted for the valve in closed position.

Standard

- » body made of spheroidal graphite iron with an epoxy coating
- » closed bonnet
- » internal control bore

Options

- » pressure gauge pre-installed
- » other inlet pressure ranges on request
- » special designs on request

Operating instructions, know how and safety instructions must be observed. All the pressure has always been indicated as overpressure. We reserve the right to alter technical specifications without notice.



K_{vs}-Values[m³/h]

nominal diameter DN

50	65	80	100	125	150
17	29	43	68	104	155

Setting Ranges [bar], Nominal Pressure PN, max. Permissible Reduction Ratio

bar	1,5 - 6	5 - 12
PN	40	40
max. Δp	1 : 5	

Pressure Control Valves

Backpressure Regulators UV 4.4

Epoxy-coated Cast Valve for medium Flow Rates



Materials

Body	spheroidal cast iron epoxy coated
Bonnet	spheroidal cast iron epoxy coated
Spring	stainless steel 55SiCr6
Internals	stainless steel
Valve Seal	NBR
O-ring (balance)	NBR

Dimensions [mm]

size	nominal diameter DN					
	50	65	80	100	125	150
A	230	290	310	350	400	450
B	83	93	100	117	135	150
C	280	320	350	420	590	690

Weights [kg]

nominal diameter DN						
50	65	80	100	125	150	
12	19	24	34	56	74	

Special designs on request.
The pressure has always been indicated as overpressure.
Mankenberg reserves the right to alter or improve the designs or specifications of the products described herein without notice.

Dimensional Drawing

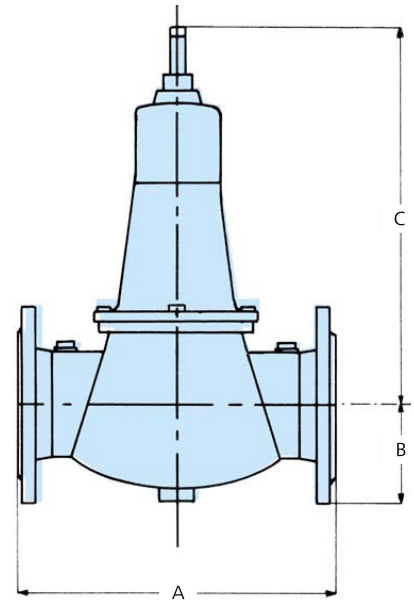

Recommended Installation

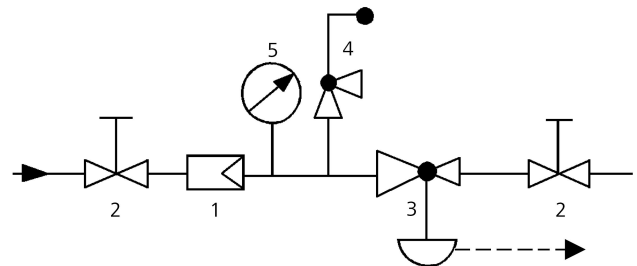

- 1 Strainer
 - 2 Shutoff valves
 - 3 Overflow Valve
 - 4 Safety Valve
 - 5 Pressure Gauge
 - 6 Leakage Line G 3/8 (option)
- use MANKENBERG-Products