

Pressure Control Valves

Pilot-operated Control Valves RP 820

Pilot-operated Backpressure Regulator



Technical Data

Connection DN	40 - 400
Nominal Pressure PN	10 - 63
Inlet Pressure	2 - 40 bar
Differential Pressure	min. 2 bar
Outlet Pressure	up to 38 bar
K _{vs} -Value	20 - 900 m ³ /h
Temperature	130 °C
Medium	liquids

Description

Medium-controlled overflow valves are simple control valves offering accurate control while being easy to install and maintain. They control the pressure upstream of the valve without requiring pneumatic or electrical control elements.

The RP 820 overflow valve is a pilot-controlled control valve consisting of a main valve, a pilot valve complete with restrictor assembly and built-in strainer mounted on the cover of the main valve, non-return valve and restrictor valves. The valve cone can be fitted with a soft or metallic seal.

When the pipeline is depressurised the main valve is kept closed by a preloaded spring. When the inlet pressure is above the set pressure the pilot valve is kept open by a piston. The control medium can flow towards the valve outlet. Restrictor D1 produces a pressure drop causing the outlet pressure to be almost equal to the pilot pressure in the main valve piston. The inlet pressure overcomes the pilot pressure and closing force of the spring and opens the main valve.

When the inlet pressure has reached the set pressure, the pilot valve restricts the flow. This causes the pilot pressure to rise and push the main valve piston into a controlling position. The restrictors D1 and D2 are used to optimise the control characteristics. The bypass fitted with a non-return valve ensures quick closing.

When the inlet pressure falls below the set pressure the pilot valve closes. The pilot pressure is equal to the inlet pressure. The main valve closes as the piston diameter is greater than the valve seat. The spring also forces the valve to close.

The valve is piped internally. The pulse lines must be installed on-site.

These valves are no shut-off elements ensuring a tight closing of the valve. In accordance with the VDI/VDE guideline 2174 a leakage rate of 0.05 percent of the constant volume flow is permitted for the valve in closed position.

Options

» special versions on request

Operating instructions, know how and safety instructions must be observed. All the pressure has always been indicated as overpressure. We reserve the right to alter technical specifications without notice.

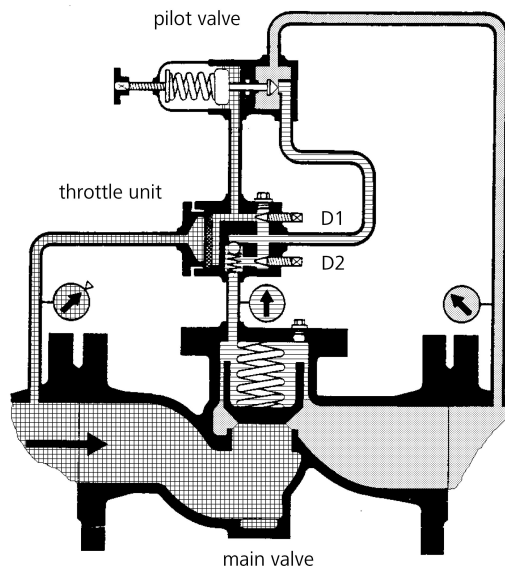

K _{vs} -Values [m ³ /h]						
nominal diameter DN	40	50	65	80	100	125
K _{vs} -value m ³ /h	20	32	50	60	70	150

K _{vs} -values [m ³ /h]						
nominal diameter DN	150	200	250	300	350	400
K _{vs} -value m ³ /h	250	350	500	600	700	900

Setting Ranges [bar], Nominal Pressure			
2 - 5	4 - 12	10 - 20	15 - 40
PN 10	PN 25	PN 40	PN 63

Pressure Control Valves

Pilot-operated Control Valves RP 820

Pilot-operated Backpressure Regulator



Materials

Temperature	80 °C	130 °C
Body	PN 10	up to DN 25 grey cast iron, from DN 40 spheroidal cast iron
	PN 25, 40, 63	cast steel
	PN 10 - 63	CrNiMo-steel
Cover	steel optional CrNiMo-steel	
Internals	CR-steel optional CrNi-steel or CrNiMo-steel	
Valve Seal	NBR	EPDM
O-Ring	NBR	EPDM
Pilot Valve	CrNiMo-steel	CrNiMo-steel
Throttle Unit		

Dimensions [mm]

nominal press. PN	size	nominal diameter DN						
		40	50	65	80	100	125	
16	A	200	230	290	310	350	400	
40	A	200	230	290	310	350	400	
63	A	260	300	340	380	430		
all PN	B	140	160	180	220	220	230	
all PN	C	200	220	250	260	280	290	

Dimensions [mm]

nominal press. PN	size	nominal diameter DN						
		150	200	250	300	350	400	
16	A	480	600	730	850	980	1100	
40	A	480	600	730	850	980		
63	A	550	650					
all PN	B	240	270	290	350	350	410	
all PN	C	330	390	420	550	550	550	

Weights [kg]

PN	nominal diameter DN											
	40	50	65	80	100	125	150	200	250	300	350	400
16	25	30	40	50	70	120	150	210	380	450	520	625
40	33	38	48	65	80	140	160	240	440	510	580	
100	40	45	55	80	110		165	290				

Special designs on request.

The pressure has always been indicated as overpressure.

Mankenberg reserves the right to alter or improve the designs or specifications of the products described herein without notice.

Dimensional Drawing

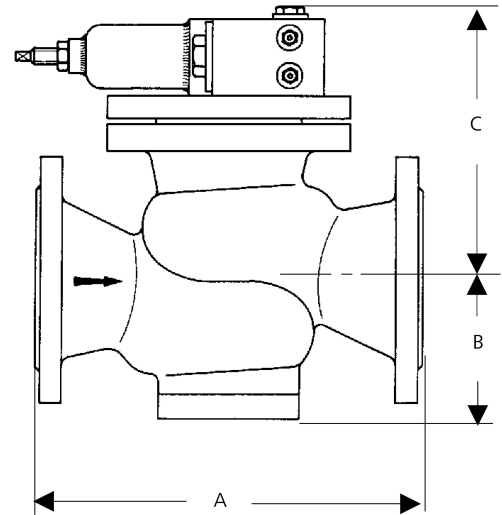

Recommended Installation

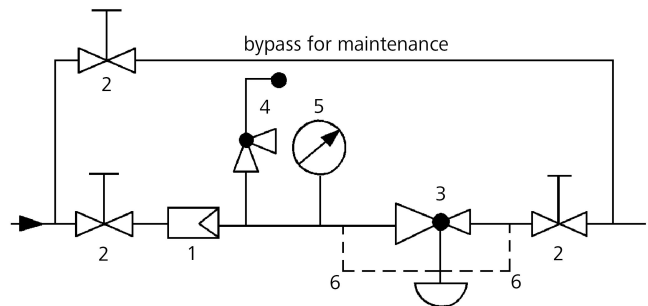

- 1 Strainer
- 2 Shut-off Valves
- 3 Overflow Valve
- 4 Safety Valves
- 5 Pressure Gauge
- 6 Sense Line

sense line connection 10 - 20 x DN before the valve
use MANKENBERG-Products