

Bleeding and Venting Valves

Continuous Bleeding and Venting Valves EB 1.12



Compact Standard Bleeding Valve

Technical Data

Connection DN	25 - 100
Connection G	3/4 - 2
Nominal Pressure PN	16
Operating Pressure	0 - 16
Flow Rate	248 Nm ³ /h
Temperature	130 °C
Medium	liquids

Description

Bleeding and venting valves remove air or gases from systems or pipelines without requiring an external energy input. When a system is drained they act as venting valves.

The EB 1.12 bleeding/venting valves are compact and lightweight float-controlled valves for water treatment (incl. ozone), pipelines, petrol tanks etc. They are manufactured from deep-drawn stainless steel featuring excellent corrosion resistance. The valve cone can be fitted with a soft or metallic seal.

Top and bottom sections of the valve body are connected by a clamp ring and two bolts. Servicing/maintenance is easy and does not call for special tooling.

The simple design makes it easy to specify, install, handle and service these valves in an industrial environment.

Valves for continuous bleeding must not be overdimensioned. If a larger valve size is selected, a higher working pressure range with a correspondingly lower flow volume should be chosen. In case of doubt we shall be happy to advise you.

On filter vessels the bleed connection is often located in the middle of the vessel. If the flow volume is large and the distance between distribution funnel and bleed connection small, the incoming water jet hits the bleed connection. This will impair the efficiency of the bleed valve and can result in water hammer. This problem may be avoided by installing a baffle or by placing the bleed connection away from the centre.

Standard

- » all stainless steel construction
- » quick-release body clamp ring

Options

- » ozone-resistant design
- » various seal materials suitable for your medium
- » plastic coating for corrosive fluids
- » special connections: Aseptic, ANSI or DIN flanges, welding spigots; other connections on request
- » special versions on request

Please state working pressure range when enquiring or ordering.

Operating instructions, know how and safety instructions must be observed. All the pressure has always been indicated as overpressure. We reserve the right to alter technical specifications without notice.



Pressure Ranges [bar]

nominal diameter G 3/4 x 1/2 A

press. range bar	0 - 2	0 - 6	0 - 16
------------------	-------	-------	--------

Pressure Ranges [bar]

nominal diameter G 1 - 2, DN 25 - 100

press. range bar	0 - 2	0 - 6	0 - 10	0 - 16
------------------	-------	-------	--------	--------

Flow Rate in Nm³/h see sheet EB 1.12/2.1.091.2

Bleeding and Venting Valves

Continuous Bleeding and Venting Valves EB 1.12

Compact Standard Bleeding Valve



Materials		
Design	standard	
Type	G 3/4 - 2, DN 25 - 50	DN 65 - 100
Temperature	130 °C	130 °C
Body	CrNiMo-steel	CrNiMo-steel
Body Seal	EPDM	EPDM
Internals	CrNiMo-steel	CrNiMo-steel
Float	CrNiMo-steel	CrNiMo-steel
Valve Seal	FPM	CrNiMo-steel
Profile Clamp	CrNiMo-steel	CrNiMo-steel

Materials		
Design	ozone resistant	
Nominal Diameter	G 3/4	G 1-2, DN 25-100
Temperature	80 °C	100 °C
Body	CrNiMo-steel	CrNiMo-steel
Body Seal	FPM	FPM
Internals	CrNiMo-steel	CrNiMo-steel
Float	CrNiMo-steel	CrNiMo-steel
Valve Seal	CSM	CrNiMo-steel
Profile Clamp	CrNiMo-steel	CrNiMo-steel

Dimensions [mm] G 3/4x1/2	
size	inlet female G 3/4, outlet male G 1/2 A
A	109
B	57
C	127
D	140

size A tolerance ± 4 mm

Weights [kg] G 3/4x1/2	
0.8	

Dimensions [mm] G 1 - 2, DN 25 - 100											
size	inlet female G				inlet flange DN						
	1	1 1/4	1 1/2	2	25	32	40	50	65	80	100
outlet male G 3/4A											
A	146	149	149	145	161	163	165	164	250	255	257
B	140	140	140	140	140	140	140	140	113	113	113
C	185	190	190	185	200	200	205	205	295	300	305
D	200	200	200	200	200	200	200	200	265	265	265

size A tolerance ± 4 mm

Weights [kg] G 1 - 2, DN 25 - 100											
inlet female G				inlet flange DN							
1	1 1/4	1 1/2	2	25	32	40	50	65	80	100	
2.6	2.6	2.7	3.1	3.5	4.2	4.2	5	11	11	12	

Special designs on request.

The pressure has always been indicated as overpressure.

Mankenberg reserves the right to alter or improve the designs or specifications of the products described herein without notice.

Dimensional Drawing

EB 1.12 3/4 x 1/2

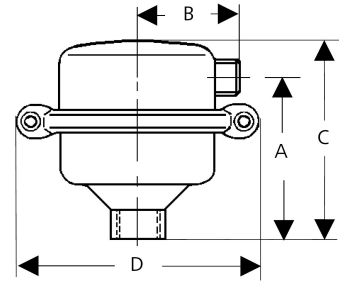

EB 1.12 G 1 - 2, DN 25 - 50

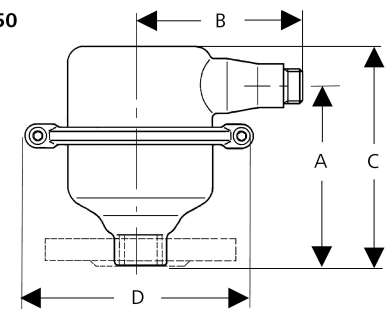

EB 1.12 DN 65 - 100

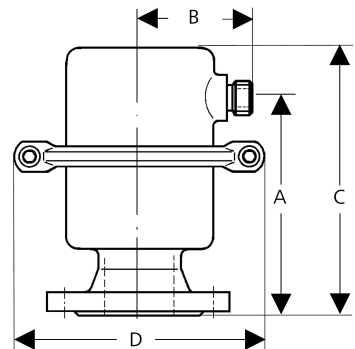

Bleeding and Venting Valves

Continuous Bleeding and Venting Valves EB 1.12



Compact Standard Bleeding Valve

Flow Rate [Nm ³ /h] G 3/4 x 1/2A			
Δp bar	pressure range bar *		
	0 - 2	0 - 6	0 - 16
0.1	3.1	1	0.3
0.2	4.4	1.4	0.4
0.5	6.8	2.2	0.6
1	8.6	2.8	0.7
2	12	4.2	1
4		7	1.7
6		9.8	2.4
8			3.1
10			3.8
12			4.5
16			5.9

Flow Rate [Nm ³ /h] G 1 - 2 x 3/4A, DN 25 - 50 x 3/4A				
Δp bar	pressure range bar *			
	0 - 2	0 - 6	0 - 10	0 - 16
0.1	14	6.4	4.1	3.1
0.2	20	9	5.7	4.4
0.5	31	13	8.9	6.8
1	39	17	11	8.6
2	59	26	16	12
4		44	28	21
6		61	39	30
8			50	38
10			62	47
12				53
16				73

Flow Rate [Nm ³ /h] DN 65 - 100 x 3/4A				
Δp bar	pressure range bar *			
	0 - 2	0 - 6	0 - 10	0 - 16
0.1	25	25	16	8
0.2	36	36	23	11
0.5	55	55	35	16
1	70	70	45	21
2	106	106	67	32
4		176	113	53
6		246	157	75
8			203	96
10			248	118
12				139
16				182

The quoted flow volumes apply to a fully open valve i.e. in start-up condition at 0 °C and 1013 mbar. With continuous bleeding e.g. of filter vessels, the maximum flow volume is 30 % less on average.

* Please note: Smaller seat diameter for higher pressure range. If the selected working pressure range is too high, the flow volume may be inadequate.

Operating instructions, know how and safety instructions must be observed. All the pressure has always been indicated as overpressure. We reserve the right to alter technical specifications without notice.