

## SEMPELL

**Sempell controlled and uncontrolled Non-Return or Swing Check Valves prevent unallowable pressure built up in the turbine coming due to back-flowing steam.**

### Features and Benefits

- low maintenance gland can be retightened
- hardfaces sealing faces at disc and body seat
- low friction by burnished shaft
- surfaces treated bearing faces on each part with relative motion
- easy to disassemble bodies
- low resistance coefficient  $x$  by favorable flow characteristic of internal structure
- actuator mounting right or left possible seen from steam flow direction
- universal connections by various design of welding ends or direct welding-in
- deviating designs of welding ends in regard of dimension and material as well as other actuators, limit switches and special designs according to customers' request can be supplied.

### Use and application of non-return valves

Type 801 is a controlled non-return valve and installed into the steam line between outlet turbine and HRSG reheater. It protects the HP turbine against backflow of the steam flow from the cold reheat line in case of standstill or at no-load condition.

Under normal operating conditions the non-return valve is kept in open position by the actuator. The disc is completely out of the steam flow. In case of malfunction the non-return valve will be closed. The closing will be initiated by an impulse and a closing spring within the actuator. The closed final position and the sealing in this position is reached by the steam pressure.

The non-return valve starts opening again from a pressure difference of about 1 bar.

The closing spring is so dimensioned that the non-return valve does not remain in closed position. Thus, no overpressure can be built in the HP part of the turbine.

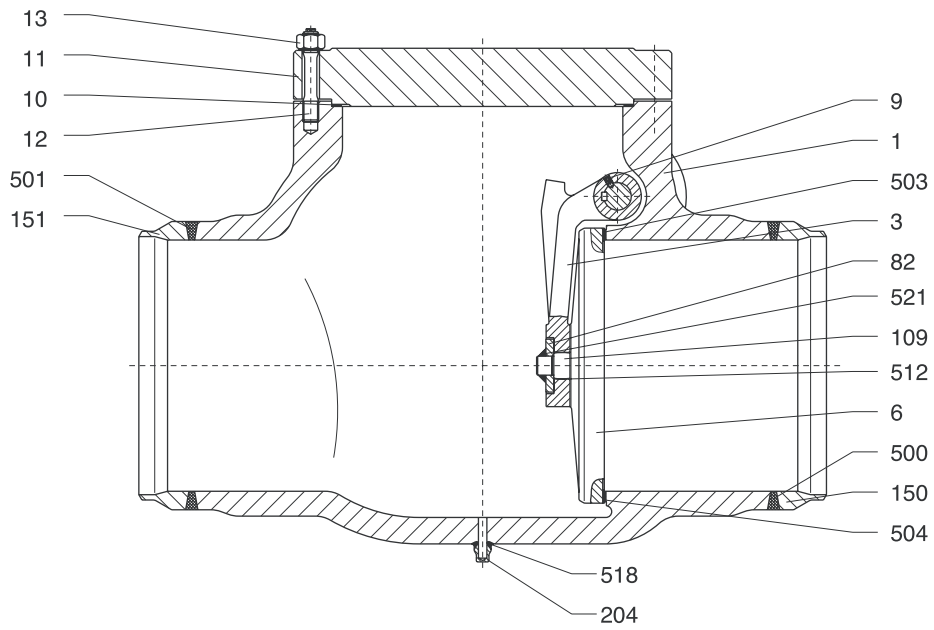
By mounting limit switches the positions OPEN/CLOSED are indicated.



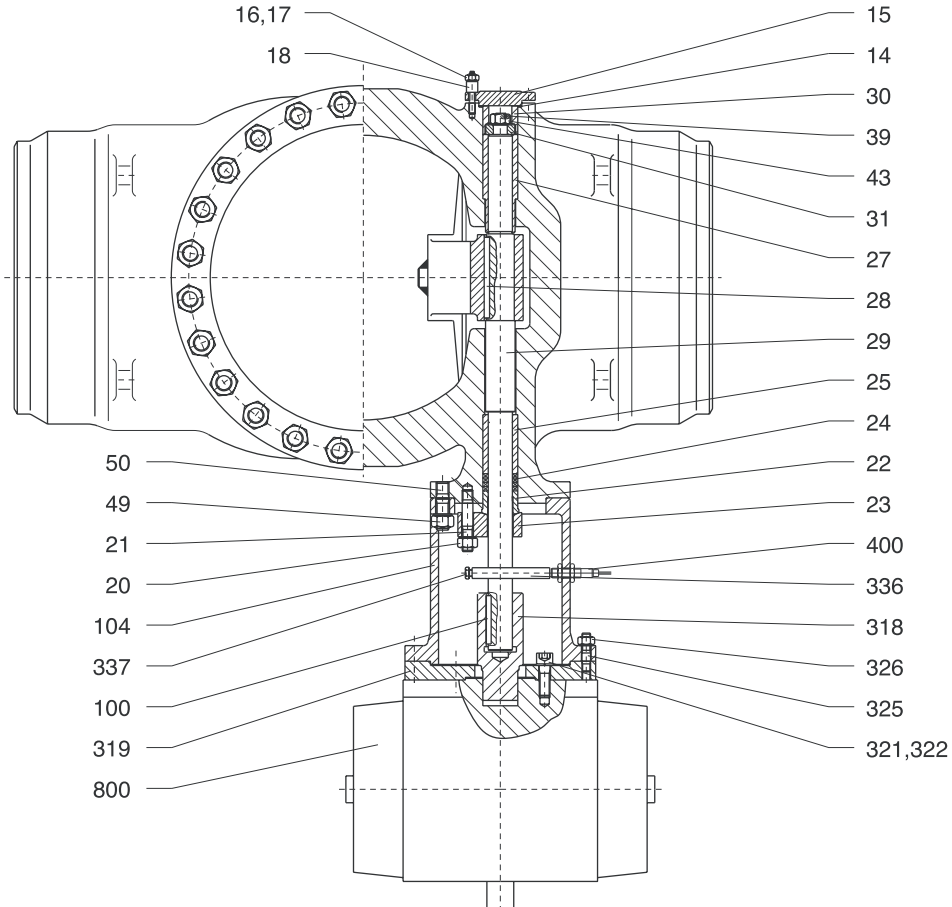
### Technical data

Size	: NPS 14" – 40"
Pressure Class	: Class 400
Connections	: Welding ends acc. to ASME
Body material	: SA217WC6
Materials internals	: Shaft 1.4122 nitriding Disc lever = body material Hardfacings 1.4115 Bearing sleeve 1.8550 nitriding
Body sealing	: Cover screwing with serrated gasket
Shaft sealing	: Molded graphite packing rings
Shaft design	: Controlled, burnished, resting into two bushes
Closing time	: < 2 sec.
Sealing body / disc	: metallic
Leakage class	: Leakage rate 2 acc. to DIN 3230 part 3 or IEC 534 part 4, Class IV, test course 2, medium L
Possible flow medium	: water, steam, gas, oil

**Figure 1**  
Design Non Return Valve

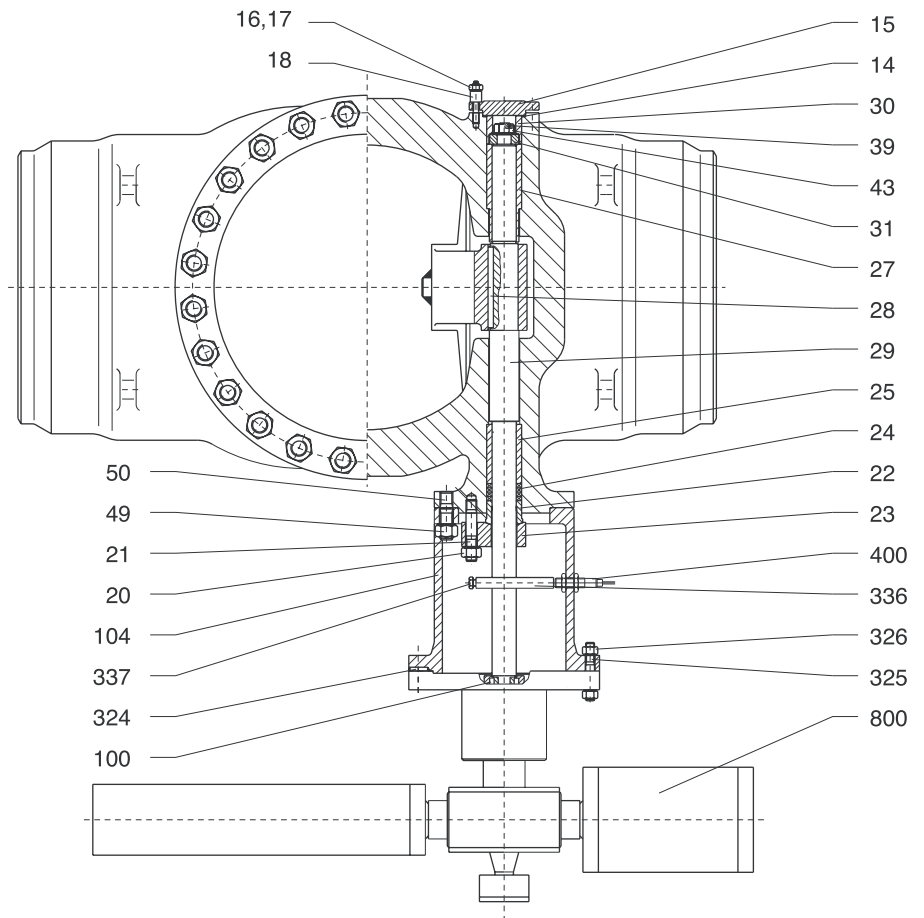


**Figure 2**  
Design with pneumatic part-turn actuator up to nominal size 28"



**Figure 3**

Design with pneumatic multi-turn actuator from nominal size 32"



**Table 1 - Materials, material specification**

Pos.	Name	ASME-Material 60	Pos.	Name	ASME-Material 60
1	Body	SA217WC6	31 •	Bearing Ring	1.8550
3	Disc Lever	SA217WC6	39	Threaded Pin	Austenit
6	Disc	1.7335	43	Hexagonal Nut	1.7258
10 •	Gasket	1.4541 / graphite	49	Hexagonal Nut	1.7258
11	Cover	SA387Gr.11Cl.2	50	Stud Screw	1.7709
12	Stud	1.7709	82	Washer	1.5415
13	Hexagonal Nut	1.7258	100 •	Parallel Key	1.4122
14 •	Gasket	1.4541 / graphite	104	Connecting Piece	1.0619
15	Cover	SA335P11	109	Bolt	1.5415
16	Hexagonal Nut	1.7258	150	Pipe Connection	SA182F12 / SA182F11
17	Stud	1.7709	151	Pipe Connection	SA182F12 / SA182F11
18	Expansion Sleeve	1.7709	204	Drainage Nozzle	SA182F12 / SA182F11
20	Hexagonal Nut	1.7258	318	Distance Piece	1.4122
21	Stud Screw	1.7709	319	Intermediate Flange	1.0425
22	Gland	1.8550	321	Lock Washer	Steel
23	Gland Flange	1.7335	322	Allan Bolt	8.8
24 •	Packing Ring	Graphite	325	Stud Screw	1.7709
25 •	Bearing Sleeve	1.8550	326	Hexagonal Nut	1.7258
27 •	Bearing Sleeve	1.8550	336	Switch Segment	1.0425
28 •	Parallel Key	1.4122	337	Hexagonal Screw	8.8
29 •	Shaft	1.4122	400 •	Proximity Switch	Div.
30 •	Bearing Sleeve	1.8550	800	Actuator	Div.

**Notes**

- Recommended spare parts

# Non-Return Valves - Type 801 ASME

## Possible applications

### Main steam

### Hot reheat

1. Cold Reheat Non Return Valve
2. Pneumatic Actuator
3. Solenoid Valves (deenergized)
4. Limit Switch

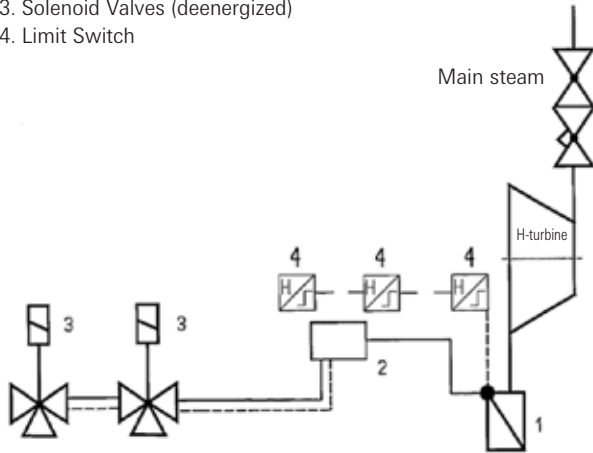


Figure 4

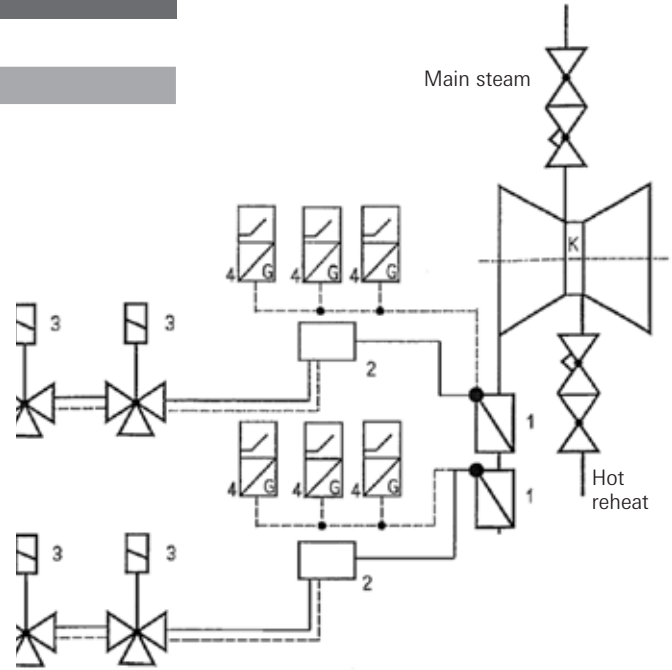


Figure 5

## Main dimensions and characteristic data of Non- Return Valves

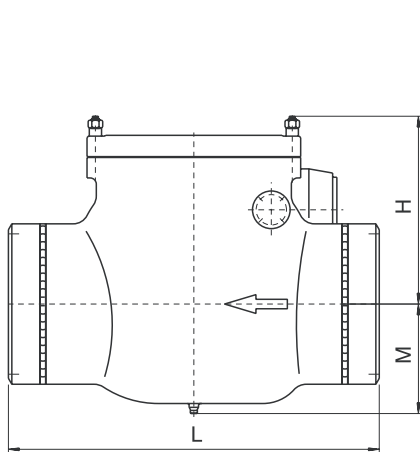


Figure 6

Drawing with welding ends and pneumatic actuator on the right

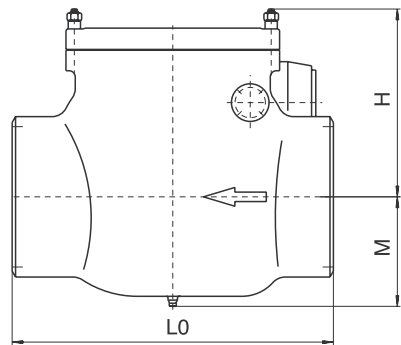
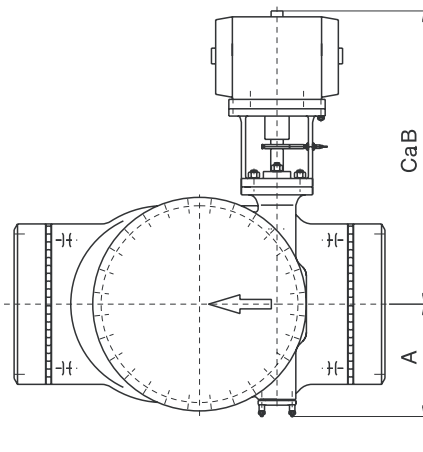


Figure 7

Drawing without welding ends

Table 2 - Dimensions and weights

NPS	seat Ø	L	L0	A	B	H	M	Weight without actuator [lbs]	
								without	welding
14"	12.99	39.37	31.50	10.63	37.80	16.54	10.24	2094.3	2314.8
16"	12.99	39.37	31.50	10.63	37.80	16.54	10.24	2094.3	2535.2
16"	14.96	43.31	35.43	12.60	40.94	20.87	12.20	2524.2	2753.5
18"	14.96	47.24	35.43	12.60	40.94	20.87	12.20	2524.2	2976.1
18"	16.73	47.24	39.37	13.98	46.26	22.44	13.78	2854.9	3097.4
20"	16.73	51.18	39.37	13.98	46.26	22.44	13.78	2854.9	3328.9
20"	18.70	51.18	43.31	15.16	50.39	23.62	14.76	3163.5	3417.1
22"	18.70	57.09	43.31	15.16	50.39	23.62	14.76	3163.5	3659.6
22"	20.47	57.09	47.43	17.32	55.12	25.98	16.73	4420.1	4739.8
24"	20.47	62.99	48.43	17.32	55.12	25.98	16.73	4420.1	5015.4
24"	22.44	62.99	55.12	18.90	58.46	28.15	17.72	5599.6	5952.3
26"	22.44	70.87	55.12	18.90	58.46	28.15	17.72	5599.6	6393.2
28"	22.44	74.80	55.12	18.90	58.46	28.15	17.72	5599.6	6911.3
28"	26.38	74.80	62.99	21.26	61.22	32.68	20.87	9600.9	10251.3
30"	26.38	76.77	62.99	21.26	61.22	32.68	20.87	9600.9	10350.5
32"	26.38	84.65	62.99	21.26	61.22	32.68	20.87	9600.9	11166.2
32"	29.92	84.65	74.02	24.02	64.96	36.81	23.62	15024.2	15806.8
36"	29.92	94.49	74.02	24.02	64.96	36.81	23.62	15024.2	16997.3
36"	33.86	94.49	83.46	26.57	71.46	41.73	26.38	19499.5	20502.6
40"	33.86	106.30	83.46	26.57	71.46	41.73	26.38	19499.5	22817.4

## Dimensions of feasible welding ends

**Table 3 - Straight nominal sizes**

NVS	seat	OD	XS	20	30	40	60	80	-	-	-	-	-
14"	12.99	355,6	12.7			11.1	15.1	19.0					
16"	14.96	406,4	12.7			12.7	16.7	21.4					
18"	16.73	457,2	12.7			14.3	19.0	23.8					
20"	18.70	508,0	12.7		12.7	15.1	20.6	26.2					
22"	20.47	558,8	12.7		12.7		22.2	28.6					
24"	22.44	609,6			14.3	17.5	24.6						
28"	26.38	711,2			15.9				15.9	17.5	20.6	22.2	25.4
32"	29.92	812,8				17.5			17.5	20.6	22.2	25.4	30.1
36"	33.86	914,4				19.0			17.5	20.6	22.2	25.4	30.1

**Table 4 - Extended pipe connections**

NPS	seat	OD	XS	20	30	40	60	80	-	-	-	-	-
16"	12.99	406.4	12.7			12.7	16.7	21.4					
18"	14.96	457.2	12.7			14.3	19	23.8					
20"	16.73	508	12.7		12.7	15.1	20.6	26.2					
22"	18.7	558.8	12.7		12.7		22.2	28.6					
24"	20.47	609.6			14.3	17.5	24.6						
26"	22.44	660.4							15.9	17.5	20.6	22.2	25.4
28"	22.44	711.2			15.9				15.9	17.5	20.6	22.2	25.4
30"	26.38	762							17.5	20.6	22.2	25.4	30.1
32"	26.38	812.8				17.5			17.5	20.6	22.2	25.4	30.1
36"	29.92	914.4				19			17.5	20.6	22.2	25.4	30.1
40"	33.86	1016							20.6	22.2	25.4	30.1	31.7

**Table 5 - Application limits subject to pressure and temperature**

**Table 5.1 - Application range ASTM materials (psig / °F)**

Class	Body material	Design temperature (°F)															
		100	200	300	400	500	600	650	700	750	800	850	900	950	1000	1050	1100
<b>STANDARD CLASS</b>																	
300	SA217WC6	750	750	720	695	665	605	590	570	530	510	485	450	320	215	145	95
400	SA217WC6	1000	1000	965	925	885	805	785	755	710	675	650	600	425	290	190	130
<b>SPECIAL CLASS</b>																	
300	SA217WC6	750	750	750	750	750	750	750	735	730	720	680	585	400	270	180	120
400	SA217WC6	1000	1000	1000	1000	1000	1000	1000	980	970	960	905	785	530	360	240	160

**Notes**

- \* Welding ends only
- Allowable working pressure (psi) test pressure acc. PED  
Test pressure = 1,5 x allowable working pressure at 100 °F

**Table 5.2 - Application range ASTM materials (psi / °C)**

Class	Body material	Design temperature (°C)															
		38	93	149	204	260	315	434	371	399	426	454	482	510	538	565	593
<b>STANDARD CLASS</b>																	
300	SA217WC6	51.8	51.8	49.7	48.0	45.9	41.8	40.7	39.3	36.6	35.2	33.5	31.1	22.1	14.9	10.0	6.6
400	SA217WC6	69.0	69.0	66.6	63.8	61.1	55.6	54.2	52.1	49.0	46.6	44.9	41.4	29.4	20.0	13.1	9.0
<b>SPECIAL CLASS</b>																	
300	SA217WC6	51.8	51.8	51.8	51.8	51.8	51.8	51.8	50.7	50.4	49.7	46.9	40.4	27.6	18.7	12.5	8.3
400	SA217WC6	69.0	69.0	69.0	69.0	69.0	69.0	69.0	67.6	66.9	66.2	62.4	54.2	36.6	24.9	16.6	11.1

**Notes**

- \* Welding ends only
- Allowable working pressure (psi) test pressure acc. PED  
Test pressure = 1,5 x allowable working pressure at 38 °C

On consultation with our engineering department the valves can be used for higher design pressures in special classes.

801	254	60	28	26,38	28	W	XXX
-----	-----	----	----	-------	----	---	-----

## Valve type

801 Non-Return Valve

## Valve Code

254 Actuator left  
255 Actuator right

## Material Specification

60 body SA217WC6

## Inlet nominal size

14" = NPS 14"  
16" = NPS 16"  
18" = NPS 18"  
20" = NPS 20"  
22" = NPS 22"  
24" = NPS 24"  
26" = NPS 26"  
28" = NPS 28"  
30" = NPS 30"  
32" = NPS 32"  
36" = NPS 36"  
40" = NPS 40"

## Accessories

see TO.130.80.xxxx D E

## Pipe Connection

W Welding end acc. to ASME  
U Plain ends

## Outlet nominal size

14" = NPS 14"  
16" = NPS 16"  
18" = NPS 18"  
20" = NPS 20"  
22" = NPS 22"  
24" = NPS 24"  
26" = NPS 26"  
28" = NPS 28"  
30" = NPS 30"  
32" = NPS 32"  
36" = NPS 36"  
40" = NPS 40"

## Seat diameter

12,99= Ø 12,99  
14,96= Ø 14,96  
16,73= Ø 16,73  
18,70= Ø 18,70  
20,47= Ø 20,47  
22,44= Ø 22,44  
26,38= Ø 26,38  
29,92= Ø 29,92  
33,86= Ø 33,86