



## SEMPELL



### Attention

**The safety of lives and property often depends on the proper operation of the pressure relief valves. Consequently, the valves should be kept clean and should be periodically tested and reconditioned to make sure they function properly.**



### WARNING

Suitability of the material and product for the use contemplated by the buyer is the sole responsibility of the buyer. Also storage, installation and proper use and application are the sole responsibility of the purchaser. Tyco Valves & Controls disclaims any and all liability arising out of same.

Any installation, maintenance, adjustment, repair and testing performed on pressure relief valves should be done in accordance with the requirements of all applicable Codes and Standards under which those performing such work should maintain proper authorization through appropriate governing authorities.

No repair, assembly and test work done by other than Tyco Valves & Controls shall be covered by the warranty extended by Tyco to its customers. You assume full responsibility for your work. In maintaining and repairing Sempell products you should use only parts manufactured by Tyco Valves & Controls. Call your nearest TV&C regional sales office or representative for a Sempell service engineer should you wish assistance with your field needs.

### General

Sempell valves have been tested and adjusted at the factory. As service conditions differ it may be necessary to make slight adjustments. These adjustments are easily made if the instructions below are carefully followed.



### Warning

**To have trouble free performance be sure to thoroughly clean the inlets and outlets of valves before installing.**

### Storage and handling

Valves are often on hand at the job site months before they are installed. Unless properly stored and protected, valve performance may be adversely affected. Rough handling and dirt may damage or cause misalignment of the valve parts. It is recommended that the valves be left in their original shipping containers and that they be stored in a warehouse or as a minimum on a dry surface with a protective covering until they are used.

Pressure relieving valves must be handled carefully and never subjected to sharp impact loads. They should not be struck, bumped or dropped. Rough handling may alter the pressure setting, deform valve parts and adversely affect seat tightness and valve performance.



### Note

**Where valves have levers as in types I and I (104) top construction, do not lift or carry valves by the levers!**

Inlet and outlet protectors should remain in place until the valve is ready to be installed on the system.

### Installation

#### • Inlet piping

The valve should be mounted vertically in an upright position either directly on a nozzle from the pressure vessel or on a short connection fitting that provides a direct, unobstructed flow between the vessel and the valve. Installing a pressure relief valve in other than this recommended position might adversely affect its operation.

A valve should never be installed on a fitting having a smaller inside diameter than the inlet connection of the valve.

Compliance with the above recommendations will assure clean positive valve operation.

Many valves are damaged when first placed in service because of failure to clean the connections properly when installed.

Both the valve inlet and the vessel and/or line on which the valve is mounted must be thoroughly cleaned of all dirt and foreign material.

#### • Outlet piping

Discharge piping should be simple and direct. A broken connection near the valve outlet is preferred. The weight of the discharge piping should be carried by a separate support and be firmly braced against swaying or vibrations.

Fittings or pipe having a smaller inside diameter than the valve outlet connections must not be used. The flow from the valve must discharge to a safe disposal area.



**The safety of lives and property often depends on the proper operation of the pressure relief valves. The valves must be maintained according to appropriate instructions and must be periodically tested and reconditioned to ensure that they function correctly.**

Sempell pressure relief valves described in this instruction are manufactured in accordance with the requirements of ASME Boiler and Pressure Vessel Code, Section VIII.

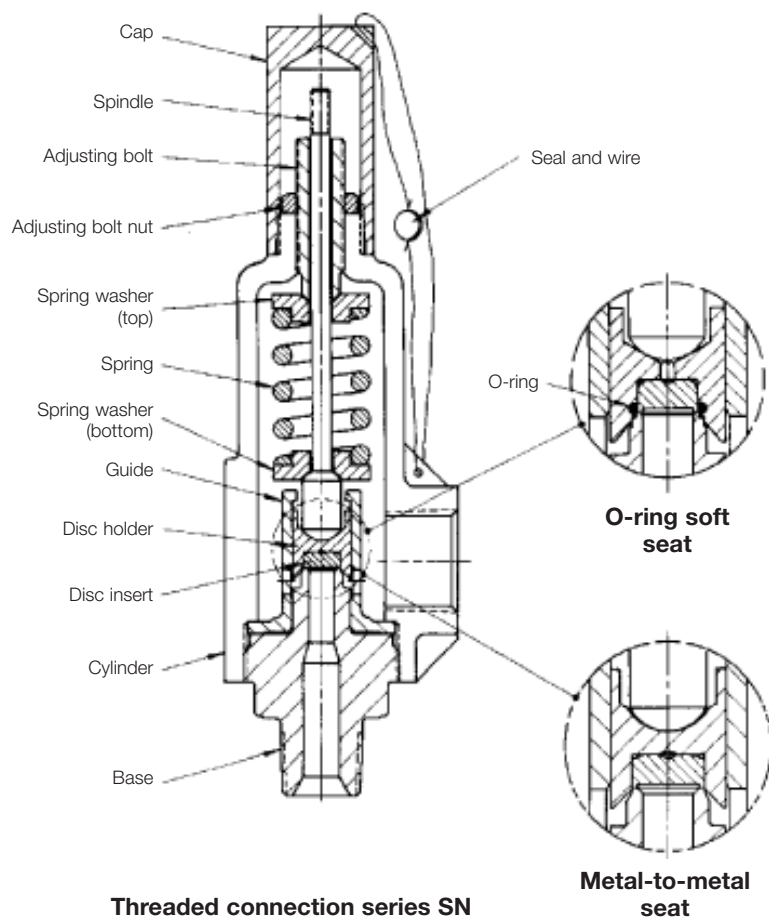

**Threaded connection series SN**

**Metal-to-metal seat**

**Testing**

Testing should be performed by trained personnel using the applicable test procedure. Follow these guidelines for performance of the set pressure test.

• *Test fluids - set pressure test*

The test fluid should be air or nitrogen for valves used on gas and vapor service and water for valves used on liquid service.

**Note:** Valves for steam service should be tested on steam. When steam testing is not possible, valves for steam service may be tested on air or nitrogen. In such cases it may be necessary to make a correction to the adjusted set pressure to compensate for the difference in temperature of the test fluids.

• *Temperature correction*

When a valve is set on air or water at room temperature and then used at a higher service temperature, the cold differential set pressure shall be corrected to exceed the set pressure using the following temperature correction:

Operating temperature		% Pressure increase
°F	°C	
0 to +150	-18 to +66	None
+151 to +600	+66 to 316	1%
+601 to +750	316 to 399	2%

• *Valve operation*

Valves intended for compressible fluid service and tested on air, nitrogen or steam will open with a sharp, clear popping action at the set point. Valves for liquid service tested with water are considered open at the first continuous unbroken stream of liquid flowing through the valve. Sometimes it is helpful to install a short piece of pipe in the valve outlet to determine the opening on water.

## Set pressure

### Set pressure changes

Set pressure changes beyond the Sempell specified spring range will necessitate a change in the valve spring assembly consisting of the spring and two washers.

The new spring and washers must be obtained from Sempell and the valve must be reset and the nameplate restamped by an authorized repair facility.

### Set pressure adjustment

Before making any adjustments reduce the pressure under the valve seat to at least 25% below the stamped opening pressure. This will prevent seat damage due to turning of the disc insert on the nozzle seat and minimize the chance of an inadvertent opening.

## Maintenance - dismantling

1. Remove the cap.
2. Before removing the adjusting bolt, take a measurement from the top of the adjusting bolt to the top of the cylinder as a reference for resetting the valve later.
3. Loosen the adjusting bolt nut and turn the adjusting bolt counterclockwise to completely remove the load on the spring. Unless this is done, unnecessary damage to the seat or misalignment of the trim parts may occur when the valve is reassembled.
4. Unscrew the cylinder from the base. Lift the cylinder from the base making sure that the guide remains on the base.  
**Note:** If the guide is not removed with the base, invert the entire valve and remove the base. Then remove the guide, disc holder and disc insert.
5. Remove the spindle, spring and spring washers.
6. Invert the base/guide/disc assembly and remove the base.
7. Remove the disc holder assembly.

#### • Metal seated valves

The disc insert is not attached to the disc holder so use care when removing this assembly.

#### • O-ring seated valves

Remove the disc insert by inserting a drive pin or similar tool into the hole in the disc holder and press out the disc insert. Remove the O-ring with a suitable tool. Be careful not to damage the O-ring groove.

## Cleaning

The following instructions are general guidelines. Certain applications may require the use of special cleaning procedures.

1. After the valve has been completely dismantled, the seats on both the nozzle and the disc insert should be examined to determine how badly they are damaged, if at all. Any severe damage may make it advisable to replace the parts.
2. External parts, such as the cylinder and cap, can be cleaned by immersion in a bath such as a hot oakite solution or equivalent.
3. Internal parts, except O-rings, can be cleaned using acetone, denatured alcohol or any other suitable solvent. Mechanical cleaning of internal parts, except seats, can be performed using fine sandpaper or emery cloth.

## Lapping of seats - metal seated valves only

Many different methods exist for lapping valve seats but certain essential steps are required for satisfactory results. Extreme care should be taken throughout to make certain that the seats are kept perfectly flat. The following procedure is suggested for lapping bases and disc inserts:

1. Never lap the disc against the base. Lap each part separately against a cast-iron lapping block of proper size. These blocks hold the lapping compound in their surface pores and must be recharged frequently.
2. Check the lapping block frequently on a good lapping block conditioner to make certain that it is perfectly flat.
3. If considerable lapping is required, spread a thin coat of medium coarse lapping compound on the block. After lapping with this, lap again with a medium grade compound. Unless much lapping is called for, the first step may be omitted. Next, lap again using a fine grade compound. Lap the block against the seat. Do not rotate the block continuously, but use an oscillating motion as in grinding automobile valves.
4. When the seat is flat and all nicks and marks have disappeared, remove all compound from the lapping block and seat. Apply polishing compound to another block and lap the seat with this. As the lapping nears completion, only the compound left in the pores of the block should be present. This should give a very smooth finish. If scratches appear, the cause is probably dirty lapping compound. These scratches should be removed by using a compound free from foreign matter.
5. After wiping off all compounds, the valve is ready for assembly.

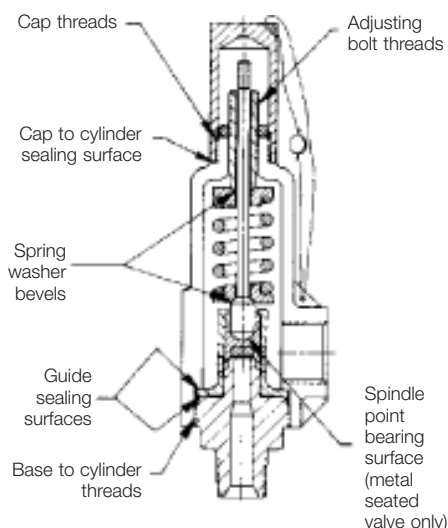

## Maintenance - assembly

1. Prior to assembly, the following parts are to be coated with a lubricant/sealant such as pure nickel "Never-Seeze" or equivalent. Other lubricants/sealants can be used depending on service conditions.
2. Disc assembly
  - *Metal seated valve*  
With the disc holder in the inverted position, drop in the disc insert.
  - *O-ring soft seated valve*  
Coat the entire O-ring (except TFE O-rings) with Parker Super O-Lube. Insert the O-ring into the groove in the disc holder. Push the disc insert into the disc holder. TFE O-rings may require the use of a small press or, with care, a hammer and a punch.
3. With the guide inverted, drop in the disc assembly.
4. With the guide still inverted, install the base into the guide.
5. The base/guide/disc assembly can now be turned upright and placed into a vise or fixture for assembly of the remaining components.
 

**Note:** Be sure to clamp only onto the wrench flats of the base.
6. Place the spring and spring washers onto the spindle.
7. While holding the spindle in place lower the cylinder into place on the base and screw tightly onto the base.
8. Screw the adjusting bolt nut onto the adjusting bolt and install into the cylinder.
9. Screw the cap onto the cylinder.

## Assembly of caps and lifting lever devices

### Type O (screwed cap)

Apply pure nickel Never-Seeze or equivalent to the cap sealing surface and screw the cap onto the top of the cylinder. Tighten the cap with a suitable wrench.

### Type O (104) (screwed cap with test rod)

Apply pure nickel Never-Seeze to the cap sealing surface and screw the cap onto the top of the cylinder. Tighten the cap with a suitable wrench. Install the cap plug O-ring and screw the cap plug into the cap. The test rod is installed only during system hydrostatic testing.



**Never install the test rod unless performing system hydrostatic testing.**

### Type I (packed lifting lever)

1. Apply Loctite 242 or equivalent to the spindle threads. Screw the spindle nut onto the spindle. Screw on the cap handtight.
2. Apply Parker Super O-Lube to the cam O-ring and install onto the cam. Insert the cam into the sleeve. Install the lever onto the cam and secure with the lever pin.
3. Screw the lever assembly into the cap. If the cam interferes with the spindle nut remove the spindle assembly and raise the spindle nut. Repeat until the spindle nut is approximately 1/16" above the cam.
4. Once the spindle nut is in position, remove the cap and screw the locknut on the spindle and, while firmly securing the spindle nut with locking pliers, tighten the locknut.
5. Apply pure nickel Never-Seeze or equivalent to the cap threads and to the cap sealing surface. Screw the cap onto the top of the cylinder. Tighten the cap with a suitable wrench.
6. Apply Parker Super O-Lube or equivalent to the cam sleeve O-ring and install the O-ring. Install the lever assembly.

### Type I (104) (packed lifting lever with test rod)

Assembly of the Type I (104) lifting lever is identical to the Type I with the addition of the cap plug O-ring and the cap plug. The test rod is installed only during system hydrostatic testing.



**Never install the test rod unless performing system hydrostatic testing.**

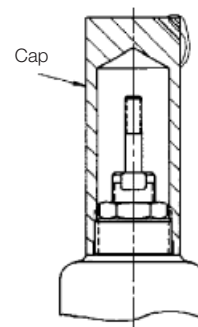

**Type O**

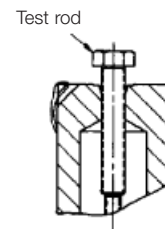

**View showing valve gaged with test rod (Types O (104) and I (104))**

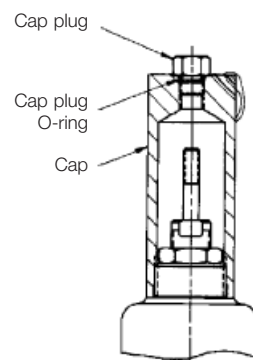

**Type O (104)**

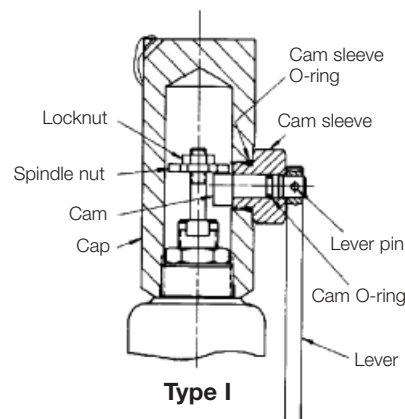

**Type I**

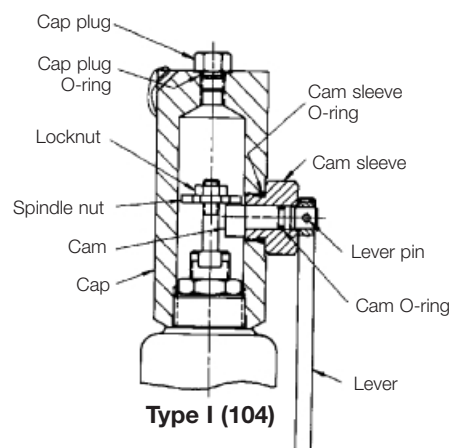

**Type I (104)**

### Replacement spare parts

#### Ordering information

Tyco recommends that a sufficient inventory of spare parts be maintained to support process requirements. Always be sure to use genuine Sempell parts to ensure continued product performance and warranty.

#### Parts

To order parts, the following information should always be included:

1. Quantity
2. Part name, i.e. (disc insert)
3. Size, style, type and valve number
4. Serial number
5. Original purchase order number (if the nameplate has been destroyed.)

**Note:** The size, style, set pressure and serial number can always be found on the valve nameplate.

#### Springs with washers

To order springs with washers, the required valve set pressure must also be specified in addition to the other parts information. Should back pressure (fixed or variable) or elevated temperature exist during operation, also specify these conditions.

For additional information about Sempell Series SN pressure relief valves, see Sempell datasheet SEMDR-0056.