



**Models 912, 913, 918, 919 ASME Section VIII,  
Steam/Air/Gas/Liquid, 'UV' National Board Certified.  
Also available for Vacuum Service.**

**Pressure and Temperature Limits**

**Models 912, 913, 918, 919**

**Steam**

3 to 250 psig [-20 to 17 barg] <sup>1</sup>  
-60° to 406°F [-51° to 208°C]

**Models 912, 918**

**Air/Gas/Liquid**

3 to 300 psig [-20 to 21 barg]  
-60° to 406°F [-51° to 208°C]

**Models 913, 919**

**Air/Gas/Liquid**

3 to 900 psig [-20 to 62 barg]  
-60° to 406°F [-51° to 208°C]

**Vacuum**

6- through 29-inch HG  
[200 through 1000 mbar] – 300°F [149°C]  
Maximum back pressure 50 psig [3 barg]  
- threaded cap and packed lever

**Applications**

- Air/gas compressors - intercoolers - aftercoolers.
- Liquid filled pressure vessels/systems - ASME Section VIII (UV).
- Pressure vessels - containing gas, air, liquid or steam. Including tanks and receivers.
- Vacuum systems including pumps, tanks and equipment.
- Optional materials for low temperature - cryogenic applications.
- Oil/gas separators.
- Overpressure relief and protection of pumps, tanks, lines and hydraulic systems.
- By-pass relief or pressure regulation.

**Features and Benefits**

- Available with soft seat.
- Threaded cap is standard (back pressure tight).
- Hex on valve nozzle provides for easy installation.
- Single control ring offers easy adjustability of blowdown.
- Pivoting disc design corrects misalignment and offers exceptional performance.
- Guide to nozzle ratio reduces friction.
- Full nozzle design for optimum flow performance.
- Threaded side outlet for piped off discharge to eliminate fugitive emissions.

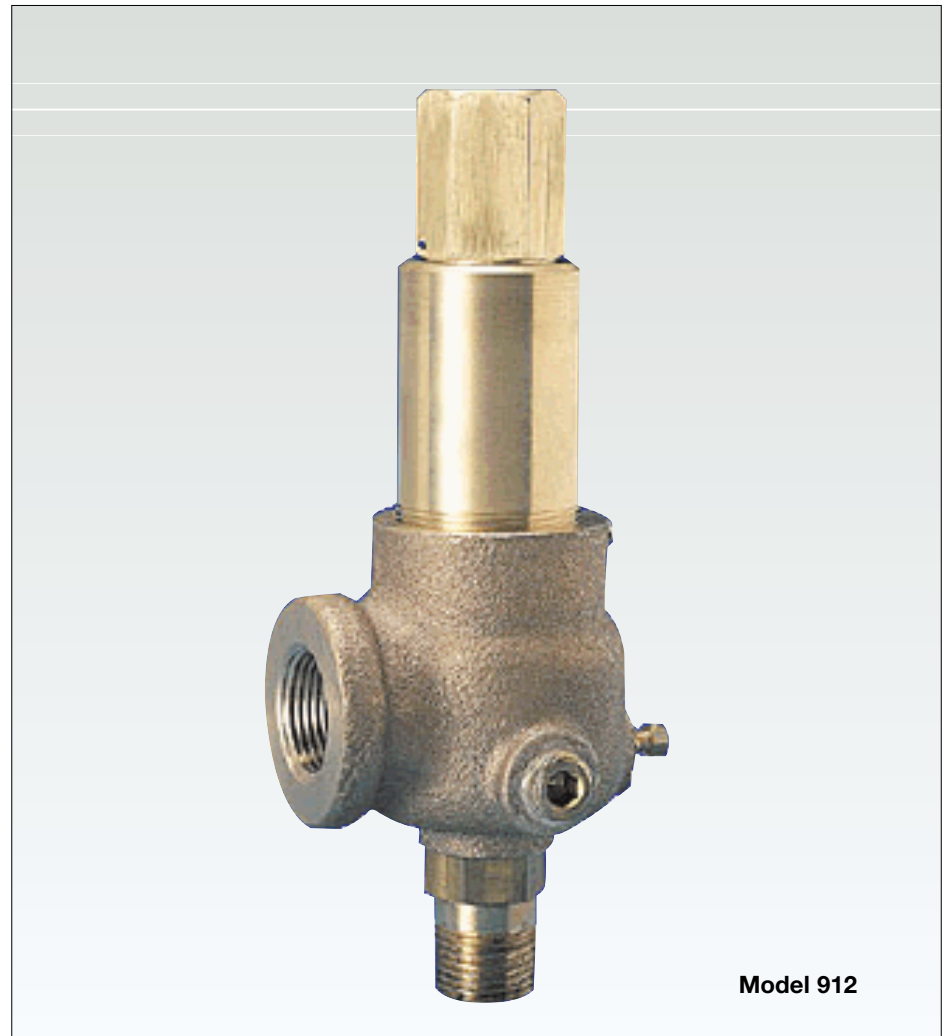

**Model Descriptions**

**Model 912:** Full nozzle design. SS warn ring and disc with brass/bronze base. Bronze/brass body and bonnet.

**Model 913:** Full nozzle design. Bronze/brass body and bonnet. 316 SS trim (base, disc and disc holder).

**Model 918:** Same as Model 912 except resilient seat/seal. Superior 'leak-free' performance.

**Model 919:** Same as Model 913 except resilient seat/seal. Superior 'leak-free' performance. Bronze body and bonnet. 316 SS trim (base, disc and disc holder).

**Options**

- Threaded cap. (Variation 01)
- Threaded cap with gag. (Variation 02)
- Plain lever. (Variation 03)
- Plain lever with gag. (Variation 04)
- Plain lever with vibration dampener. (Variation 05)
- Packed lever. (Variation 06)
- Packed lever with gag. (Variation 07)

**Note**

1. ASME standard valves for air or steam service must have lift lever. For steam boilers and generators.

**Models 912, 913, 918, 919** ASME Section VIII, Steam/Air/Gas/ Liquid,  
'UV' National Board Certified. Also available for Vacuum Service

**Service Recommendations for Resilient Seat/Seal Materials**

Seat/Seal Materials <sup>1</sup>	Service Recommendation
BUNA-N (-40° to 200°F) [-40° to 93°C]	Air, Anhydrous Ammonia, Butane, Carbon Dioxide, Diesel Oil, Ethyl Chloride, Ethyl Ether, Freons #11 and 12, Fuel Oil, Gasoline, Helium, Hydrogen Sulphide, Kerosene, Lube Oil, Natural Gas, Nitrogen, Oxygen (Gas), Propane, Propylene, Sulphur Dioxide, Vinyl Chloride
Viton® A (-10° to 406°F) [-23° to 208°C]	Acetone, Air, Amyl Alcohol, Aniline, Benzene, Butane, Carbon Disulphide, Carbon Tetrachloride, Dowtherm 'A' and 'E', Ethyl Chloride, Ethylene, Ethylene Glycol, Ethyl Alcohol, Gasoline, Hexane, Hydrogen Sulphide, Isobutyl Alcohol, JP - 4 Fuel, JP - 5 Fuel, Kerosene, Lube Oil, Natural Gas, Naphtha, Nitrogen, Propane, Propylene, Propyl Alcohol, Sulphur Dioxide, Toluene, Trichloroethylene, Turpentine, Water, Xylene
Silicone (-100° to 406°F) [-73° to 208°C]	Air, Helium, Nitrogen, Oxygen (Gas)
Ethylene Propylene (-70° to 400°F) [-57° to 205°C]	Steam, Hot Water
Neoprene (-45° to 300°F)[-43° to 149°C]	Air, Anhydrous Ammonia, Butane, Butyl Alcohol, Castor Oil Denatured Alcohol, Ethanol, Ethyl Alcohol, Freons (12, 13, 14 and 22), Glycols, Natural Gas and Silicate Esters

**Note**

- These recommendations are a guide only.  
For the final selection of the proper material, your experience with available elastomers of various lading fluids should be considered.

**Specifications**

Model <sup>2</sup> Number	Orifice	Connections		Maximum Set Pressure		Dimensions, in [mm]									Approx. Weight lb [kg]
		ANSI Standard Inlet	ANSI Standard Outlet	912-918 <sup>4</sup>	913-919 <sup>5</sup>	A	B	C			C				
								Plain Lever	Threaded Cap	Packed Lever					
9*BDC	D	1/2" [12.7]	3/4" [19.0]	300 [20.7]	900 [62.1]	2 3/8 [60]	1 5/8 [41]	8 3/8 [213]	7 1/4 [184]	9 [229]	3 [1.4]				
9*BDC	D	1/2" [12.7]	1" [25.4]	300 [20.7]	900 [62.1]	2 3/8 [60]	1 5/8 [41]	8 3/8 [213]	7 1/4 [184]	9 [229]	3 [1.4]				
9*BDD <sup>3</sup>	D	3/4" [19.0]	3/4" [19.0]	—	900 [62.1]	2 3/8 [60]	1 5/8 [41]	8 3/8 [213]	7 1/4 [184]	9 [229]	3 [1.4]				
9*BDE <sup>3</sup>	D	1" [25.4]	1" [25.4]	—	900 [62.1]	2 5/8 [67]	1 5/8 [41]	8 5/8 [219]	7 1/2 [191]	9 1/8 [232]	3 [1.4]				
9*BED	E	3/4" [19.0]	1 1/4" [31.8]	300 [20.7]	900 [62.1]	2 5/8 [67]	2 [51]	8 3/4 [222]	7 5/8 [194]	9 3/8 [238]	4 [1.8]				
9*BEF <sup>3</sup>	E	1 1/4" [31.8]	1 1/4" [31.8]	—	900 [62.1]	3 [76]	2 [51]	9 1/8 [232]	8 [203]	9 3/4 [248]	4 [1.8]				
9*BFE	F	1" [25.4]	1 1/2" [38.1]	300 [20.7]	600 [41.4]	2 7/8 [73]	2 3/8 [60]	9 7/8 [251]	8 3/4 [222]	10 1/2 [267]	6 [2.7]				
9*BFG <sup>3</sup>	F	1 1/2" [38.1]	1 1/2" [38.1]	—	600 [41.4]	3 [76]	2 3/8 [60]	10 [254]	8 7/8 [225]	10 5/8 [270]	6 [2.7]				
9*BGF	G	1 1/4" [31.8]	2" [50.8]	300 [20.7]	600 [41.4]	3 1/4 [89]	2 5/8 [67]	11 1/4 [286]	10 1/8 [257]	11 3/4 [298]	8 [3.6]				
9*BGH <sup>3</sup>	G	2" [50.8]	2" [50.8]	—	600 [41.4]	3 1/4 [89]	2 5/8 [67]	11 1/4 [286]	10 1/8 [257]	11 3/4 [298]	8 [3.6]				
9*BHG	H	1 1/2" [38.1]	2 1/2" [63.5]	300 [20.7]	500 [34.5]	3 1/2 [89]	2 3/4 [70]	13 [330]	11 1/8 [283]	12 1/2 [318]	11 [5.0]				
9*BJH	J <sup>6</sup>	2" [50.8]	3" [76.2]	300 [20.7]	500 [34.5]	4 [102]	3 1/4 [89]	14 1/2 [368]	12 1/2 [318]	15 1/8 [384]	15 [6.8]				

**Notes**

- Maximum temperature controlled by resilient seat/seal material.
- Replace asterisk with desired Model Number. Data applicable to all models.
- Available with SS trim only.
- Maximum pressure on steam is 250°F.
- Maximum pressure on steam is 300°F.
- For C dimensions: pressures above 200 psig [14 barg] add 1.25-inch [31.8 mm] to the overall height.

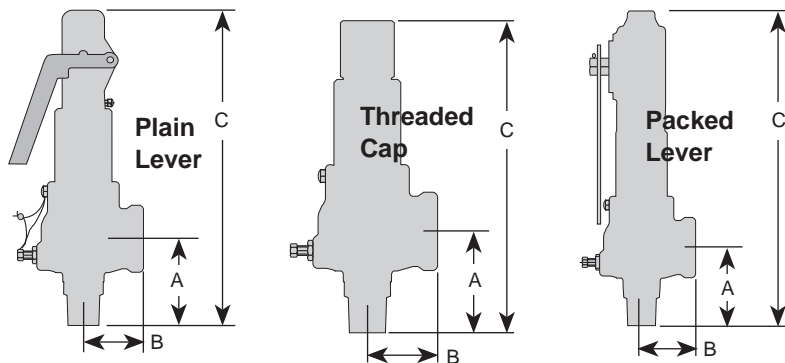

**Models 912, 913, 918, 919** ASME Section VIII, Steam/Air/Gas/  
Liquid, 'UV' National Board Certified. Also available for Vacuum Service

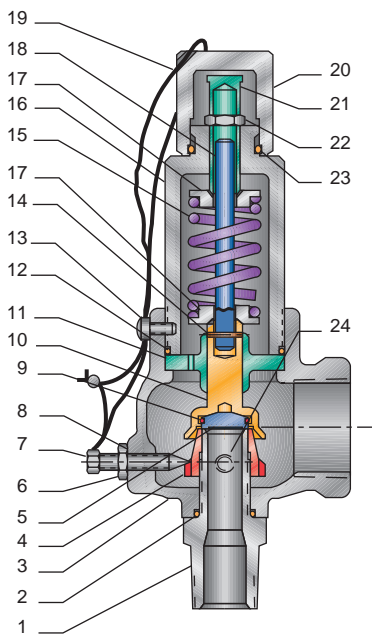

**Parts and Materials - Models 912, 913, 918, 919 Threaded Cap**

No.	Part Name	Materials
1	Nozzle <sup>1</sup>	Brass, B21 Alloy 485, (SS, A351-CF8M <sup>1</sup> Models 913, 919 only)
2	O-ring Body	Teflon®
3	Body	Bronze, B584 Alloy 84400
4	Warn Ring	SS, A743-CF8M
5	Disc <sup>2</sup>	SS, A479-316
6	Set Screw Nut	Brass, B16
7	Set Screw	Brass, B16
8	Seal	Teflon®
9	Retainer Ring	SS, A313-316
10	Disc Holder	Brass, B16, (SS A351-CF8M Models 913, 919 only)
11	Guide <sup>3</sup>	Brass, B16
12	Bonnet O-ring	Teflon®
13	Screw	SS, Commercial 18-8
14	Coiled Spring Pin	SS, A313-302
15	Spring	Steel A231/A231M, Cadmium Plated SS: A313-302 SS: A313-316 Alloy steel: A681-H12
16	Bonnet <sup>4</sup>	Brass, B16
17	Spring Step	Brass, B16
18	Stem	Brass, B16
19	Wire and Seal	SS wire and Lead seal, Commercial
20	Cap	Brass, B16
21	Compression Screw	Brass, B16
22	Jam Nut	Brass, B16
23	Cap O-ring	BUNA-N
24	Body Plug <sup>5</sup>	Brass, B16
25	Guide Guide Locknut Shield	Brass, B16 Brass, B16 SS, A167-316
26	Disc Holder Spindle	Brass, B16 (Model 912 only) Brass, B16 (Model 912 only)

**Notes**

- F through J orifice nozzle material is Bronze, B62.
- Material Letter Designation  
Viton®-A A  
BUNA-N B  
Silicone S
- G through J orifice guide material is Bronze, B584, Alloy 84400.
- F through J orifice bonnet material is Bronze, B584, Alloy 84400.
- Body plug and tapped hole not available for liquid service.

**Models 912, 913, 918, 919** ASME Section VIII, Steam/Air/Gas/  
Liquid, 'UV' National Board Certified. Also available for Vacuum Service

**Parts and Materials - Model 912 Packed Lever**

No.	Part Name	Materials
18	Cap O-ring	BUNA-N 70 Duro, Commercial
19	Jam Nut	Brass, B16
20	Lift Cam	SS, A743 CF8M
21	Cotter Pin	Steel, Commercial
22	Lever	Zinc Plated Steel, A108
23	Drive Screw	SS, Commercial
24	Retainer Nut	Brass, B16
25	Retainer O-ring	BUNA-N 70 Duro, Commercial
26	Lift Cam O-ring	BUNA-N 70 Duro, Commercial
27	Cap	Bronze, B584 Alloy 84400
28	Lift Nut	SS, A479 316
29	Lift Washer	SS, A479 316
30	Stem	Brass, B16
31	Compression Screw	Brass, B16
32	Coiled Spring Pin	SS, A313 302
33	Body Plug <sup>4</sup>	Brass, B16
34	Guide Guide Locknut Shield	Brass, B16 Brass, B16 SS, A167 316

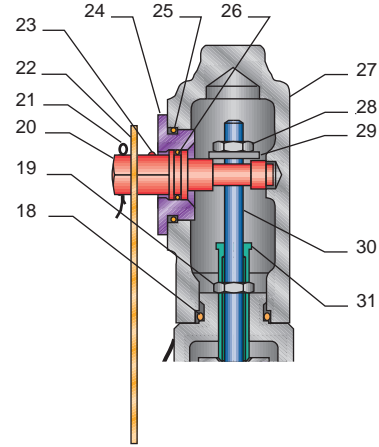

**Parts and Materials - Model 912 Plain Lever**

No.	Part Name	Materials
11	Spring	Cadmium plated steel: A231/A231M SS: A313-302 SS: A313-316 Alloy steel: A681-H12
12	Bonnet <sup>3</sup>	Brass, B16
13	Jam Nut	Brass, B16
14	Compression Screw	Brass, B16
15	Lever	Steel Cadmium Plated, A109
16	Cap	Brass, B179
17	Lift Nut	SS, A479-316
18	Lift Washer	SS, A479-316
19	Rivet	Steel, Commercial
20	Screw	SS, Commercial GR. 18-8
21	Spring Step	Brass, B16
22	Disc Holder Spindle	Brass, B16 Brass, B16

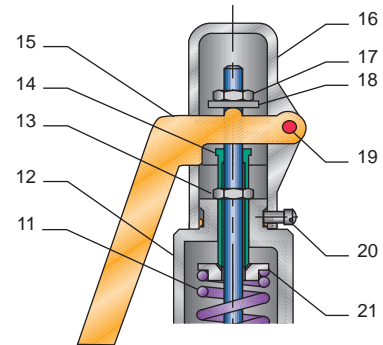

**Models 912, 913, 918, 919** ASME Section VIII, Steam/Air/Gas/  
Liquid, 'UV' National Board Certified. Also available for Vacuum Service

**Model Number/Order Guide**

Model Number Position	0	1	2	3	4	5	6	7	8	9	10	11	12	13	14	15	
<b>Example</b>	9	1	2	B	J	H	M	0	1	—	K	C	0	3	0	0	
<b>Model</b>	912		913		918		919										
<b>Connection Model</b>	B - Male x Female Threaded or NPT																
<b>Orifice</b>	D	E	F	G	H	J											
<b>Inlet Size</b>	C - 1/2-inch [15 mm]		D - 3/4-inch [18 mm]		E - 1-inch [25 mm]		F - 1 1/4-inch [32 mm]		G - 1 1/2-inch [40 mm]		H - 2-inch [50 mm]						
<b>Seat/Seal Material</b>	M - Metal-to-metal B - BUNA-N 200°F [93°C] E - EPR 350°F [177°C] S - Silicone 406°F [208°C] V - Viton® 406°F [208°C] N - Neoprene 300°F [149°C]																
<b>Variation (01 through 99)</b>	Number provided only by manufacturer to cover specific feature or option. 01 - Threaded cap 02 - Threaded cap with gag 03 - Plain lever 04 - Plain lever with gag 05 - Plain lever with vibration dampener 06 - Packed lever 07 - Packed lever with gag																
<b>Design Revision</b>	Indicates non-interchangeable revision. Dash (-) if original design.																
<b>Valve Service</b>	J - Liquid ASME Section VIII (Standard Cap/Packed Lever only) K - Air/Gas ASME Section VIII (Plain Lever/Packed Lever required for air) L - Steam ASME Section VIII (Plain Lever/Packed Lever required) M - Liquid (Standard Cap/Packed Lever only) Q - Vacuum (Standard Cap/Packed Lever only)																
<b>Spring Material</b>	E - SS																
<b>Set Pressure</b>	3 psig [0.2 barg] (0003) through 900 psig [62 barg] (0900) Vacuum 6-inch HG [200 mbarg] (0006) through 29-inch HG [1000 mbarg] (0029)																

## Models 920, 921, 927

### ASME Section I Steam (English, lb/h) - Flow Coefficient = 0.878<sup>1</sup>

Set Pressure (psig)	Orifice Area, in <sup>2</sup>					
	D (0.1213)	E (0.2157)	F (0.3369)	G (0.553)	H (0.864)	J (1.415)
15	174	309	482	792	1237	2026
25	228	406	635	1042	1628	2665
35	283	504	787	1292	2018	3305
45	338	601	939	1541	2408	3944
55	393	699	1091	1791	2798	4583
65	448	796	1243	2041	3189	5222
75	504	896	1399	2297	3589	5877
85	560	996	1556	2554	3991	6536
95	617	1097	1713	2812	4393	7194
100	645	1147	1791	2940	4594	7523
125	786	1398	2183	3583	5599	9169
150	927	1649	2575	4227	6604	10815
175	1068	1900	2967	4870	7609	12461
200	1209	2150	3359	5513	8614	14107
225	1350	2401	3751	6156	9619	15753
250	1492	2652	4143	6800	10624	17399
275	1633	2903	4534	7443	11629	19045
300	1774	3154	4926	8086	12634	20691
325	1915	3405	5318	8730	13639	22337
350	2056	3656	5710	9373	14644	23983
375	2197	3907	6102	10016	15649	25629
400	2338	4158	6494	10659	16654	27275
425	2479	4409	6886	11303	17659	28921
450	2620	4660	7278	11946	18664	30567
475	2761	4910	7670	12589	19669	32212
500	2902	5161	8061	13232	20674	33858
525	3044	5412	8453	13876	—	—
550	3185	5663	8845	14519	—	—
575	3326	5914	9237	15162	—	—
600	3467	6165	9629	15805	—	—
625	3608	6416	—	—	—	—
650	3749	6667	—	—	—	—
675	3890	6918	—	—	—	—
700	4031	7169	—	—	—	—
725	4172	7419	—	—	—	—
750	4313	7670	—	—	—	—
775	4455	7921	—	—	—	—
800	4596	8172	—	—	—	—

### Note

1. Pressure and Temperature Limitations  
Steam Section I - 'V' Special Use  
15 to 800 psig  
-20° to 800°F

## Models 920, 921, 927

### Note

1. Pressure and Temperature Limitations  
Steam Section I - 'V' Special Use  
1 to 55 barg  
-28° to 427°C

### ASME Section I Steam [Metric, kg/h] - Flow Coefficient = 0.878<sup>1</sup>

Set Pressure [barg]	Orifice Area, cm <sup>2</sup>					
	D [0.7826]	E [1.3916]	F [2.1735]	G [3.5677]	H [5.574]	J [9.129]
1.1	81	144	225	370	578	946
2.0	114	202	315	518	809	1325
3.0	150	266	415	682	1065	1745
4.0	186	330	516	846	1322	2165
5.0	222	395	617	1013	1582	2591
6.0	259	461	720	1182	1846	3024
7.0	296	527	823	1351	2111	3457
8.0	333	593	926	1520	2375	3890
9.0	371	659	1029	1689	2640	4323
10.0	408	725	1132	1859	2904	4756
12.0	482	857	1339	2197	3433	5622
14.0	556	989	1545	2536	3961	6488
16.0	630	1121	1751	2874	4490	7354
18.0	705	1253	1957	3212	5019	8220
20.0	779	1385	2163	3551	5548	9086
22.0	853	1517	2369	3889	6077	9952
24.0	927	1649	2576	4228	6605	10818
26.0	1002	1781	2782	4566	7134	11684
28.0	1076	1913	2988	4905	7663	12550
30.0	1150	2045	3194	5243	8192	13416
32.0	1224	2177	3400	5582	8720	14282
34.0	1299	2309	3607	5920	9249	15148
36.0	1373	2441	3813	6259	—	—
38.0	1447	2573	4019	6597	—	—
40.0	1521	2705	4225	6935	—	—
42.0	1596	2837	—	—	—	—
44.0	1670	2969	—	—	—	—
46.0	1744	3101	—	—	—	—
48.0	1818	3233	—	—	—	—
50.0	1893	3365	—	—	—	—
52.0	1967	3497	—	—	—	—
54.0	2041	3629	—	—	—	—
58.0	2190	3893	—	—	—	—
62.0	2338	4157	—	—	—	—

## Models 910, 911, 912, 913, 916, 917, 918, 919

Non-code<sup>1</sup> and ASME Section VIII Air (English, SCFM) -  
Flow Coefficient = 0.878

Set Pressure (psig)	Orifice Area, in <sup>2</sup>					
	D (0.1213)	E (0.2157)	F (0.3369)	G (0.553)	H (0.864)	J (1.415)
3	28	50	77	127	198	325
4	32	57	89	146	228	374
5	36	64	99	163	255	417
6	39	70	109	178	278	456
7	42	75	117	192	300	491
8	45	80	125	205	320	524
9	48	85	132	217	338	554
10	50	89	139	228	356	583
11	52	93	145	238	372	610
12	54	97	151	248	388	635
13	57	101	157	258	403	660
14	59	104	163	267	417	683
15	64	114	177	291	455	745
25	83	148	232	380	594	972
35	104	185	288	474	740	1212
45	125	223	348	571	893	1462
55	147	261	408	669	1046	1713
65	168	299	467	767	1199	1963
75	190	337	527	865	1352	2214
85	211	376	587	963	1505	2464
95	233	414	646	1061	1658	2715
100	243	433	676	1110	1734	2840
125	297	528	825	1355	2116	3466
150	351	624	974	1599	2499	4093
175	405	719	1124	1844	2881	4719
200	458	815	1273	2089	3264	5345
225	512	910	1422	2334	3646	5971
250	566	1006	1571	2578	4029	6598
275	619	1101	1720	2823	4411	7224
300	673	1197	1869	3068	4793	7850
325	727	1292	2018	3313	5176	8477
350	780	1388	2167	3558	5558	9103
375	834	1483	2316	3802	5941	9729
400	888	1579	2466	4047	6323	10355
425	941	1674	2615	4292	6705	10982
450	995	1769	2764	4537	7088	11608
475	1049	1865	2913	4781	7470	12234
500	1102	1960	3062	5026	7853	12861
550	1210	2151	3360	5516	—	—
600	1317	2342	3658	6005	—	—
650	1425	2533	—	—	—	—
700	1532	2724	—	—	—	—
750	1639	2915	—	—	—	—
800	1747	3106	—	—	—	—

### Notes

- No code stamp or 'NB' on nameplate below 15 psig set.
- Pressure Limitations  
**Models 910, 916:** 3 to 900 psig  
**Models 911, 917:** 3 to 900 psig  
**Models 912, 918:** 3 to 250 psig  
**Models 913, 919:** 3 to 900 psig



## Models 910, 911, 912, 913, 916, 917, 918, 919

### Notes

- No code stamp or 'NB' on nameplate below 1.1 barg set.
- Pressure Limitations  
**Models 910, 916:** 0.2 to 62 barg  
**Models 911, 917:** 0.2 to 62 barg  
**Models 912, 918:** 0.2 to 17 barg  
**Models 913, 919:** 0.2 to 62 barg

### Non-code<sup>1</sup> and ASME Section VIII Air [Metric, Nm<sup>3</sup>/h] - Flow Coefficient = 0.878

Set Pressure [barg]	Orifice Area, cm <sup>2</sup>					
	D [0.7826]	E [1.3916]	F [2.1735]	G [3.5677]	H [5.574]	J [9.129]
0.2	45	80	126	206	322	528
0.5	71	126	196	323	504	825
1.0	98	175	273	448	700	1147
2.0	151	268	419	687	1074	1758
3.0	202	359	561	920	1438	2355
4.0	253	451	704	1155	1805	2956
5.0	305	542	847	1390	2172	3557
6.0	356	634	990	1625	2538	4157
7.0	408	725	1133	1860	2905	4758
8.0	459	817	1276	2094	3272	5359
9.0	511	908	1419	2329	3639	5960
10.0	562	1000	1562	2564	4006	6560
12.0	665	1183	1848	3033	4739	7762
14.0	768	1366	2134	3503	5473	8963
16.0	871	1549	2420	3972	6206	10165
18.0	974	1733	2706	4442	6940	11366
20.0	1077	1916	2992	4911	7673	12567
22.0	1180	2099	3278	5381	8407	13769
24.0	1283	2282	3564	5851	9141	14970
26.0	1386	2465	3850	6320	9874	16172
28.0	1489	2648	4136	6790	10608	17373
30.0	1592	2831	4422	7259	11341	18574
32.0	1695	3015	4708	7729	12075	19776
34.0	1798	3198	4994	8198	12808	20977
36.0	1901	3381	5280	8668	—	—
38.0	2004	3564	5567	9137	—	—
40.0	2107	3747	5853	9607	—	—
42.0	2210	3930	—	—	—	—
44.0	2313	4113	—	—	—	—
46.0	2416	4297	—	—	—	—
48.0	2519	4480	—	—	—	—
50.0	2622	4663	—	—	—	—
52.0	2725	4846	—	—	—	—
54.0	2828	5029	—	—	—	—
56.0	2931	5212	—	—	—	—
58.0	3034	5395	—	—	—	—
60.0	3137	5579	—	—	—	—
62.0	3240	5762	—	—	—	—

## Models 910, 911, 912, 913

Non-code<sup>1</sup> and ASME Section VIII Steam (English, lb/h) -  
Flow Coefficient = 0.878

Set Pressure (psig)	Orifice Area, in <sup>2</sup>					
	D (0.1213)	E (0.2157)	F (0.3369)	G (0.553)	H (0.864)	J (1.415)
3	87	155	242	398	621	1017
4	100	178	278	456	712	1167
5	111	197	308	506	791	1295
6	121	215	336	551	861	1410
7	130	231	360	591	924	1513
8	138	245	383	628	981	1607
9	145	258	403	662	1035	1694
10	152	271	423	694	1084	1776
11	159	282	441	724	1131	1852
12	165	293	458	752	1175	1924
13	171	304	474	778	1216	1992
14	176	313	489	803	1255	2056
15	179	319	498	818	1278	2092
25	234	416	650	1068	1668	2732
35	292	519	810	1330	2078	3404
45	352	626	978	1605	2508	4108
55	412	733	1146	1880	2938	4811
65	473	841	1313	2155	3368	5515
75	533	948	1481	2430	3797	6219
85	593	1055	1648	2706	4227	6923
95	654	1163	1816	2981	4657	7627
100	684	1216	1900	3118	4872	7979
125	835	1484	2319	3806	5946	9738
150	986	1753	2737	4493	7020	11498
175	1136	2021	3156	5181	8095	13257
200	1287	2289	3575	5869	9169	15017
225	1438	2557	3994	6556	10243	16776
250	1589	2826	4413	7244	11318	18536
275	1740	3094	4832	7932	12392	20295
300	1891	3362	5251	8619	13467	22055
325	2041	3630	5670	9307	14541	23814
350	2192	3898	6089	9994	15615	25574
375	2343	4167	6508	10682	16690	27333
400	2494	4435	6927	11370	17764	29093
425	2645	4703	7346	12057	18838	30852
450	2796	4971	7765	12745	19913	32612
475	2946	5239	8183	13433	20987	34371
500	3097	5508	8602	14120	22061	36131
550	3399	6044	9440	15496	—	—
600	3701	6581	10278	16871	—	—
650	4002	7117	—	—	—	—
700	4304	7653	—	—	—	—
750	4606	8190	—	—	—	—
800	4907	8726	—	—	—	—

### Notes

- No code stamp or 'NB' on nameplate below 15 psig set.
- Pressure Limitations  
**Model 910:** 3 to 900 psig  
**Model 911:** 3 to 900 psig  
**Model 912:** 3 to 250 psig  
**Model 913:** 3 to 300 psig

## Models 910, 911, 912, 913

### Notes

- No code stamp or 'NB' on nameplate below 1.1 barg set.
- Pressure Limitations  
**Model 910:** 0.2 to 62 barg  
**Model 911:** 0.2 to 62 barg  
**Model 912:** 0.2 to 17.2 barg  
**Model 913:** 0.2 to 20.7 barg

### Non-code<sup>1</sup> and ASME Section VIII Steam, [Metric, kg/h]- Flow Coefficient = 0.878

Set Pressure [barg]	Orifice Area, cm <sup>2</sup>					
	D [0.7826]	E [1.3916]	F [2.1735]	G [3.5677]	H [5.574]	J [9.129]
0.2	39	69	108	177	277	453
0.5	60	106	166	272	425	697
1.0	81	144	225	369	577	945
2.0	116	207	323	529	827	1355
3.0	156	277	432	709	1108	1815
4.0	195	347	542	890	1391	2278
5.0	235	418	653	1071	1673	2741
6.0	275	488	763	1252	1956	3204
7.0	314	559	873	1433	2239	3666
8.0	354	629	983	1614	2521	4129
9.0	394	700	1093	1795	2804	4592
10.0	433	771	1204	1976	3087	5055
12.0	513	912	1424	2337	3652	5981
14.0	592	1053	1644	2699	4217	6907
16.0	671	1194	1865	3061	4782	7832
18.0	751	1335	2085	3423	5348	8758
20.0	830	1476	2306	3785	5913	9684
22.0	910	1617	2526	4146	6478	10610
24.0	989	1758	2746	4508	7043	11535
26.0	1068	1900	2967	4870	7609	12461
28.0	1148	2041	3187	5232	8174	13387
30.0	1227	2182	3408	5594	8739	14313
32.0	1306	2323	3628	5955	9304	15238
34.0	1386	2464	3849	6317	9870	16164
36.0	1465	2605	4069	6679	—	—
38.0	1544	2746	4289	7041	—	—
40.0	1624	2887	4510	7403	—	—
42.0	1703	3029	—	—	—	—
44.0	1783	3170	—	—	—	—
46.0	1862	3311	—	—	—	—
48.0	1941	3452	—	—	—	—
50.0	2021	3593	—	—	—	—
52.0	2100	3734	—	—	—	—
54.0	2179	3875	—	—	—	—
56.0	2259	4016	—	—	—	—
58.0	2338	4157	—	—	—	—
60.0	2417	4299	—	—	—	—
62.0	2497	4440	—	—	—	—

## Models 910, 911, 912, 913, 916, 917, 918, 919

Non-code<sup>1</sup> and ASME VIII Liquid (English, GPM) -  
Flow Coefficient = 0.710

Set Pressure (psig)	Orifice Area, in <sup>2</sup>					
	D (0.1213)	E (0.2157)	F (0.3369)	G (0.553)	H (0.864)	J (1.415)
3	6	11	17	27	42	69
4	7	12	19	31	49	80
5	8	14	21	35	55	90
6	8	15	23	38	60	98
7	9	16	25	41	65	106
8	10	17	27	44	69	113
9	10	18	29	47	73	120
10	11	19	30	50	77	127
11	11	20	32	52	81	133
12	12	21	33	54	85	139
13	12	22	34	56	88	144
14	13	23	36	57	92	150
15	14	25	39	63	99	162
25	17	31	48	79	123	202
35	20	36	56	93	145	237
45	23	41	64	105	164	269
55	26	45	71	116	181	297
65	28	49	77	126	197	323
75	30	53	83	136	212	347
85	32	56	88	144	225	369
95	34	60	93	153	238	390
100	34	61	95	156	244	400
125	38	68	107	175	273	448
150	42	75	117	192	299	490
175	45	81	126	207	323	530
200	49	86	135	221	346	566
225	52	92	143	235	367	601
250	54	97	151	247	387	633
275	57	101	158	259	405	664
300	60	106	165	271	423	694
325	62	110	172	282	441	722
350	64	114	178	293	457	749
375	67	118	185	303	473	775
400	69	122	191	313	489	801
425	71	126	197	323	504	825
450	73	129	202	332	519	849
475	75	133	208	341	533	873
500	77	136	213	350	547	895
550	81	143	224	367	—	—
600	84	150	234	383	—	—
650	88	156	—	—	—	—
700	91	161	—	—	—	—
750	94	167	—	—	—	—
800	97	173	—	—	—	—

### Notes

1. No code stamp or 'NB' on nameplate below 15 psig set.
2. Pressure Limitations  
**Model 910, 916:** 3 to 900 psig  
**Model 911, 917:** 3 to 900 psig  
**Model 912, 918:** 3 to 250 psig  
**Model 913, 919:** 3 to 300 psig

## Models 910, 911, 912, 913, 916, 917, 918, 919

### Notes

- No code stamp or 'NB' on nameplate below 1.1 barg set.
- Pressure Limitations  
**Model 910, 916:** 0.2 to 62 barg  
**Model 911, 917:** 0.2 to 62 barg  
**Model 912, 918:** 0.2 to 17.2 barg  
**Model 913, 919:** 0.2 to 20.7 barg

### Non-code<sup>1</sup> and ASME Section VIII Liquid, [Metric m<sup>3</sup>/h] - Flow Coefficient = 0.710

Set Pressure [barg]	Orifice Area, cm <sup>2</sup>					
	D [0.783]	E [1.392]	F [2.174]	G [3.568]	H [5.574]	J [9.129]
0.2	1	2	4	6	9	15
0.5	2	4	6	10	15	24
1.0	3	6	9	14	22	36
2.0	4	7	12	19	30	49
3.0	5	9	14	23	37	60
4.0	6	11	16	27	42	69
5.0	7	12	18	30	47	77
6.0	7	13	20	33	52	85
7.0	8	14	22	36	56	92
8.0	8	15	23	38	60	98
9.0	9	16	25	41	63	104
10.0	9	17	26	43	67	110
12.0	10	18	29	47	73	120
14.0	11	20	31	51	79	130
16.0	12	21	33	54	85	139
18.0	13	22	35	57	90	147
20.0	13	24	37	61	95	155
22.0	14	25	39	63	99	162
24.0	15	26	40	66	104	170
26.0	15	27	42	69	108	177
28.0	16	28	44	72	112	183
30.0	16	29	45	74	116	190
32.0	17	30	47	77	120	196
34.0	17	31	48	79	123	202
36.0	18	32	49	81	—	—
38.0	18	33	51	83	—	—
40.0	19	33	52	86	—	—
42.0	19	34	—	—	—	—
44.0	20	35	—	—	—	—
46.0	20	36	—	—	—	—
48.0	21	37	—	—	—	—
50.0	21	37	—	—	—	—
52.0	21	38	—	—	—	—
54.0	22	39	—	—	—	—
56.0	22	40	—	—	—	—
58.0	23	40	—	—	—	—
60.0	23	41	—	—	—	—
62.0	23	42	—	—	—	—

## Models 910, 911, 912, 913, 916, 917, 918, 919

Non-code Liquid - 25% Accumulation (English, GPM) -  
Flow Coefficient = 0.710

Set Pressure (psig)	Orifice Area, in <sup>2</sup>					
	D (0.1213)	E (0.2157)	F (0.3369)	G (0.553)	H (0.864)	J (1.415)
3	6	11	18	29	45	74
4	7	13	20	33	52	85
5	8	15	23	37	58	95
6	9	16	25	41	64	105
7	10	17	27	44	69	113
8	10	18	29	47	74	121
9	11	20	30	50	78	128
10	12	21	32	53	82	135
11	12	22	34	55	86	142
12	13	23	35	58	90	148
13	13	23	37	60	94	154
14	14	24	38	62	98	160
15	14	25	39	65	101	165
25	18	33	51	83	130	213
35	22	38	60	99	154	253
45	25	44	68	112	175	286
55	27	48	75	124	193	317
65	29	52	82	134	210	344
75	32	56	88	144	226	370
85	34	60	94	154	240	394
95	36	63	99	163	254	416
100	37	65	102	167	261	427
125	41	73	114	186	291	477
150	45	80	124	204	319	523
175	48	86	134	221	345	565
200	52	92	144	236	369	604
225	55	98	152	250	391	640
250	58	103	161	264	412	675
275	61	108	169	277	432	708
300	63	113	176	289	451	739
325	66	117	183	301	470	769
350	68	122	190	312	488	799
375	71	126	197	323	505	827
400	73	130	203	334	521	854
425	75	134	210	344	537	880
450	78	138	216	354	553	905
475	80	142	221	364	568	930
500	82	145	227	373	583	954
550	86	153	238	391	—	—
600	90	159	249	409	—	—
650	93	166	—	—	—	—
700	97	172	—	—	—	—
750	100	178	—	—	—	—
800	103	184	—	—	—	—
850	107	190	—	—	—	—

### Note

- Pressure Limitations  
**Models 910, 916:** 3 to 900 psig  
**Models 911, 917:** 3 to 900 psig  
**Models 912, 918:** 3 to 250 psig  
**Models 913, 919:** 3 to 300 psig

## Models 910, 911, 912, 913, 916, 917, 918, 919

### Note

1. Pressure Limitations

**Models 910, 916:** 0.2 to 62 barg

**Models 911, 917:** 0.2 to 62 barg

**Models 912, 918:** 0.2 to 17.2 barg

**Models 913, 919:** 0.2 to 20.7 barg

### Non-code Liquid - 25% Accumulation, [Metric, m<sup>3</sup>/h] Flow Coefficient = 0.710

Set Pressure [barg]	Orifice Area, cm <sup>2</sup>					
	D [0.783]	E [1.392]	F [2.174]	G [3.568]	H [5.574]	J [9.129]
0.2	1	3	4	6	10	17
0.5	2	4	6	10	16	26
1.0	3	6	9	14	23	37
2.0	4	8	12	20	32	52
3.0	5	10	15	25	39	64
4.0	6	11	18	29	45	74
5.0	7	13	20	32	50	83
6.0	8	14	22	35	55	90
7.0	8	15	23	38	60	98
8.0	9	16	25	41	64	104
9.0	9	17	26	43	68	111
10.0	10	18	28	46	71	117
12.0	11	19	30	50	78	128
14.0	12	21	33	54	84	138
16.0	13	23	35	58	90	148
18.0	13	24	37	61	96	157
20.0	14	25	39	65	101	165
22.0	15	26	41	68	106	173
24.0	16	28	43	71	110	181
26.0	16	29	45	74	115	188
28.0	17	30	47	76	119	195
30.0	17	31	48	79	123	202
32.0	18	32	50	82	128	209
34.0	18	33	51	84	131	215
36.0	19	34	53	87	—	—
38.0	20	35	54	89	—	—
40.0	20	36	56	91	—	—
42.0	21	36	—	—	—	—
44.0	21	37	—	—	—	—
46.0	21	38	—	—	—	—
48.0	22	39	—	—	—	—
50.0	22	40	—	—	—	—
52.0	23	41	—	—	—	—
54.0	23	41	—	—	—	—
56.0	24	42	—	—	—	—
58.0	24	43	—	—	—	—
60.0	25	44	—	—	—	—
62.0	25	44	—	—	—	—

**Models 910, 911, 912, 913, 916, 917, 918, 919**

Non-code Vacuum Air (English, SCFM) Flow Coefficient = 0.878

Set Inches Mercury	Orifice Area, in <sup>2</sup>					
	D (0.1213)	E (0.2157)	F (0.3369)	G (0.553)	H (0.864)	J (1.415)
6	24	43	68	111	173	284
7	26	45	71	117	182	298
8	27	47	74	121	189	310
9	27	49	76	125	195	320
10	28	50	78	128	199	327
11	28	51	79	129	202	331
12	29	51	80	131	204	334
13	29	51	80	131	204	335
14	29	51	80	131	204	335
15	29	51	80	131	204	335
16	29	51	80	131	204	335
17	29	51	80	131	204	335
18	29	51	80	131	204	335
19	29	51	80	131	204	335
20	29	51	80	131	204	335
21	29	51	80	131	204	335
22	29	51	80	131	204	335
23	29	51	80	131	204	335
24	29	51	80	131	204	335
25	29	51	80	131	204	335
26	29	51	80	131	204	335
27	29	51	80	131	204	335
28	29	51	80	131	204	335
29	29	51	80	131	204	335



## Models 910, 911, 912, 913, 916, 917, 918, 919

Non-code Vacuum Air [Metric, Nm<sup>3</sup>/h] - Flow Coefficient = 0.878

Set Pressure [mbarg]	Orifice Area, cm <sup>2</sup>					
	D [0.7826]	E [1.3916]	F [2.1735]	G [3.5677]	H [5.574]	J [9.129]
200	40	71	111	182	285	466
225	42	74	115	189	296	485
250	43	76	119	196	306	501
275	44	78	123	201	314	515
300	45	80	125	206	321	526
325	46	82	127	209	327	535
350	46	83	129	212	331	542
375	47	83	130	214	334	548
400	47	84	131	215	336	551
425	47	84	132	216	337	553
450	47	84	132	216	337	552
475	47	84	132	216	338	553
500	47	84	132	216	338	553
525	47	84	132	216	338	553
550	47	84	132	216	338	553
575	47	84	132	216	338	553
600	47	84	132	216	338	553
625	47	84	132	216	338	553
650	47	84	132	216	338	553
675	47	84	132	216	338	553
700	47	84	132	216	338	553
725	47	84	132	216	338	553
750	47	84	132	216	338	553
775	47	84	132	216	338	553
800	47	84	132	216	338	553
845	47	84	132	216	338	553
850	47	84	132	216	338	553
875	47	84	132	216	338	553
900	47	84	132	216	338	553
925	47	84	132	216	338	553
950	47	84	132	216	338	553
975	47	84	132	216	338	553
1000	47	84	132	216	338	553