

## GACHOT TYPE V16 BALL VALVES

CARBON STEEL / FULL BORE / DN 8 TO DN 150

Carbon steel, forged body full bore ball valve designed to international and European standards



### FEATURES

- Three-piece ball valve featuring a unique design for easy and fast maintenance.
- Forged body and connectors.
- Suitable for ON-OFF and control service.
- ISO 5211 top plate flange allows the mounting of ¼ turn actuators without removing the valve body.
- Antistatic device to ISO 7121 and BS-5351.
- Guided blow-out proof stem.
- Fully adjustable packing gland.
- Fugitive emission free packing- TA-LUFT certified available upon request.
- Tightness to ISO 5208: Cat. A bubble tight.
- Standard DIN 50049-3.1.B certificate available.
- Modular "V16 SYSTEM" for check valve, strainer, sight-glass.
- A wide range of seating materials available. (PTFE, TFM, PVG, PEEK, etc.).
- Large range of options and special applications (3-way valves, tank bottom valve, cryogenic application, dead volume free design, very high temperature operation, etc.).
- Various agreements and certifications.

### APPLICATIONS

- Saturated steam.
- Ammonia, natural gas, propane and utilities.
- Whenever safety and reliability are important issues.

### TECHNICAL DATA

Sizes (DN): 8 - 150  
 Temperature (°C): -60 to +225  
 Pressure (bar): PN10 - PN 100  
 Connections: butt weld ends, socket weld ends, threaded ends  
 BSPP and NPT, forged flanges, face to face dimension to ISO 5752 series 1 and EN 558-1, special connections on request.

# GACHOT TYPE V16 BALL VALVES

MATERIALS FULL BORE / DN 8 TO DN 50

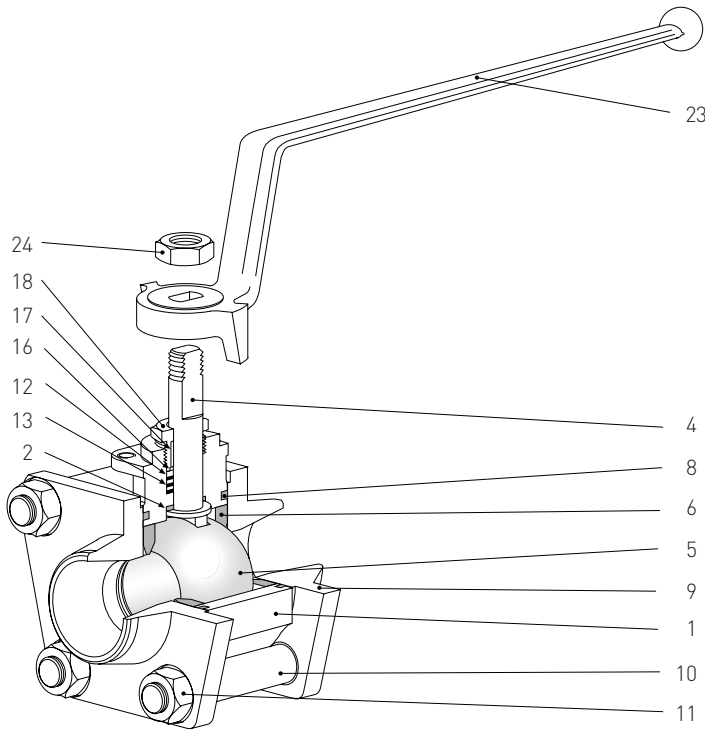

## PARTS LIST

Item	Qty	Description	Material
1	1	Body	ASTM A 105 (forged)
2	1	Friction washer	PTFE
3	1	Antistatic spring DN 50	AISI 316
4	1	Stem	AISI 316L
5	1	Ball	DN 08 to DN 20 AISI 316L <sup>[1]</sup> DN 25 to DN 50 AISI 410
6	2	Seat	DN 08 to DN 40 PTFE/Glass <sup>[2]</sup> DN 50 PTFE
7	2	Seat support DN 50	AISI 316L
8	2	Body gasket	PTFE <sup>[2]</sup>
9	2	Flanged end connector	
9A	2	End connector	ASTM A105 (forged)
9B	2	Flange	AFNOR BF 42 (forged)
10	4	Tie bolt	5.6 - 2 ISO 898-1
11	8	Nut	DN 08 to DN 40 AISI 304 DN 50 Cl. 8 steel, cadmium pl.
12	1/2	Soft gland washer	PTFE <sup>[3]</sup>
13	1/3	Metallic gland washer	AISI 316L <sup>[3]</sup>
15	2	Gland stud DN 50	AISI 316L
16	1	Spring wire	AISI 316
17	1	Gland ring DN 25 to DN 50	PTFE
18	1	Gland	DN 08 to DN 15 AISI 316L DN 20 to DN 40 AISI 1146 DN 50 A 105
19	2	Gland nut DN 50	AISI 304
20	1	Stop screw DN 08 to DN 40	AISI 304
21	1	Travel stop DN 50	C. steel
22	2	Stop screw DN 50	AISI Cl. 8.8 steel, cadmium pl.
23	1	Lever	Malleable iron
24	1	Lever Nut	ANSI 304

- 1. Ball on AISI 316L for DN 25 to DN 50 upon request
- 2. Other materials upon request
- 3. x/. for DN 08 to DN 20 FB  
.y for DN 25 to DN 50 FB

All indicated materials are equivalent standard designations.

## ANTISTATIC DEVICE

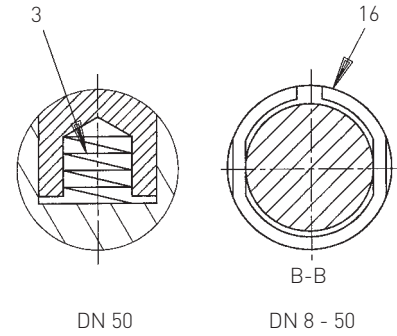

## PACKING AND ANTI BLOW-OUT STEM

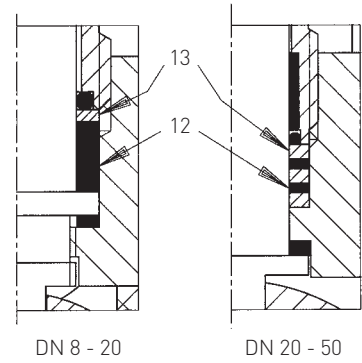

## METAL SEAT SUPPORT FOR DN 50

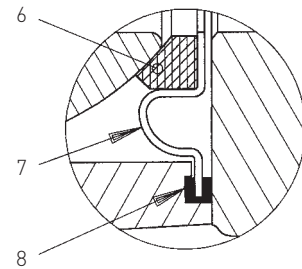

## BOLTED GLAND FOR DN 50

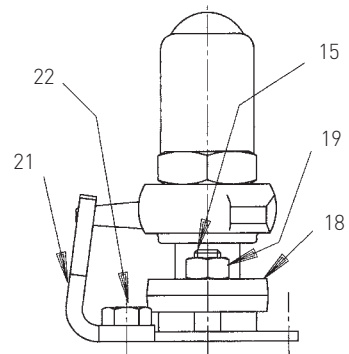

# GACHOT TYPE V16 BALL VALVES

DIMENSIONS FULL BORE / DN 8 TO DN 50

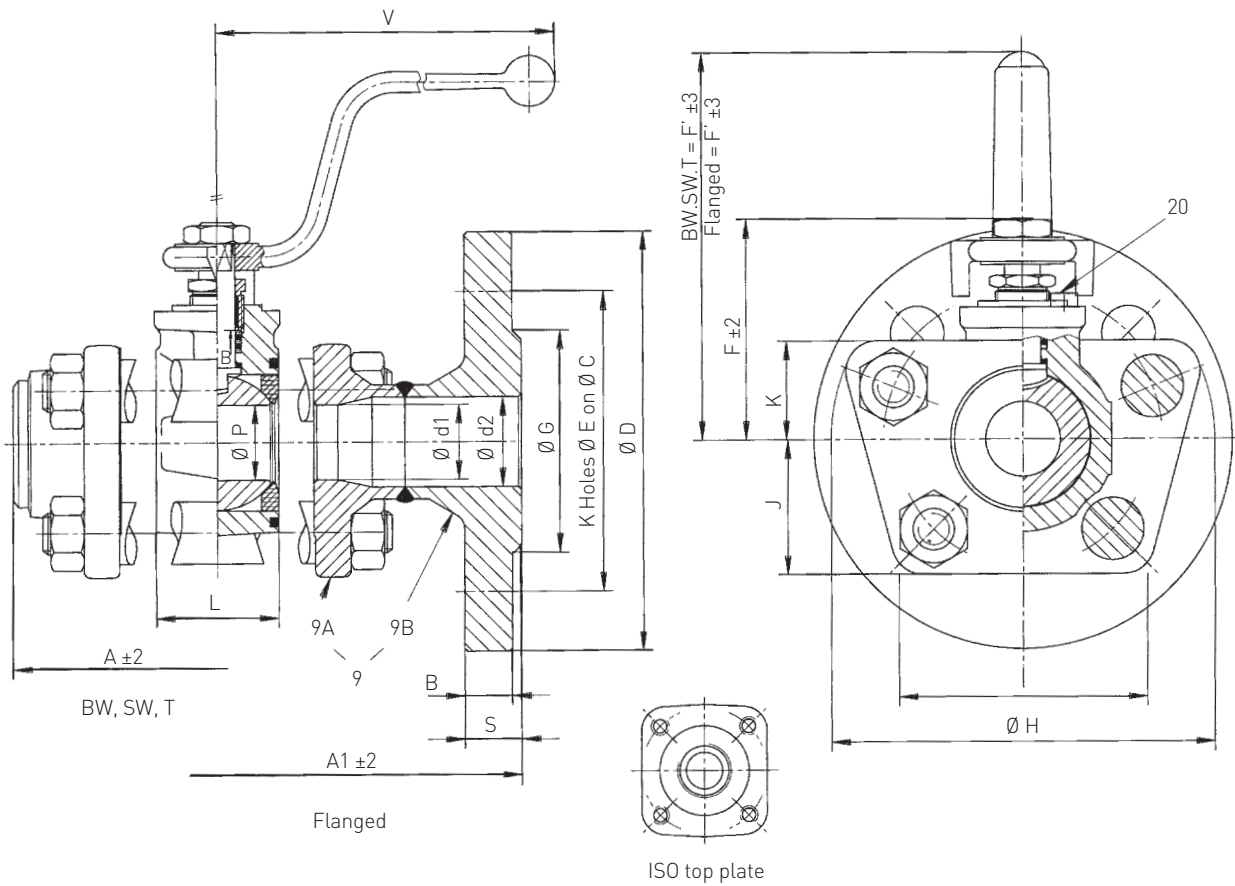

## VALVE DIMENSIONS (mm)

DN	ISO	A	A1	B	C	d1	d2	D	E	F	F'	F''	G	H	I	J	K	L	P	S	V	Weight (kg)		
																						Flanged	BW	
08	F03	67		14	60	8		90	14	57	77	109		74	48	26	19	22	11			160		0.90
10/12	F03	67	130	14	60	11	11.0	90	14	57	77	109	40	74	48	26	19	22	11	18	160		1.8	0.90
15	F03	80	130	14	65	14	16.0	95	14	60	80	112	45	82	55	30	21	25	14	18	160		2.7	1.25
20	F04	90	150	16	75	18	21.6	105	14	70	123	123	58	100	64	34	26	31	17	20	210		3.7	2.05
25	F04	100	160	16	85	25	28.5	115	14	72	127	127	68	114	72	38	32.5	41	25	20	210		5.5	2.80
32	F05	109	180	16	100	30	37.2	140	18	81	132	132	78	134	83	44	38	48	30	20	210		6.0	3.80
40	F05	130	200	15	110	40	43.1	150	18	97	140	140	88	154	96	50	45	60	40	20	260		9.6	6.00
50	F07	195	230	17	125	50	54.3	165	18	119	161	161	102	188	113	60	60	75	50	22	315		12.0	11.00

Standard flanges, PN 25/PN 40, Ra 6.3 facing. On request: flanges ANSI 150, ANSI 300.

## V-SHAPED CONNECTOR DIMENSIONS

DN	A°	R1	B°	R2	C
8	68	27.0	45	24.5	8.5
10	68	27.0	45	24.5	8.5
12	68	27.0	45	24.5	8.5
15	68	30.5	45	28.0	8.5
20	68	37.5	45	34.0	10.5
25	61°30'	45.5	45	38.9	10.5
32	61°30'	53.0	45	43.0	12.5
40	61°30'	61.0	45	51.3	14.5
50	55	78.5	45	63.0	17.0

The V-shaped connectors feature the easiest and fastest maintenance.

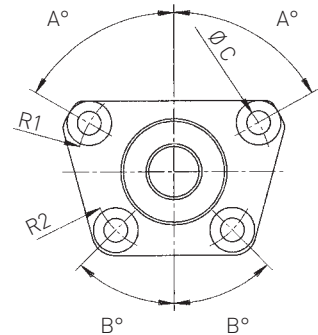

# GACHOT TYPE V16 BALL VALVES

## END CONNECTIONS AND RATINGS FULL BORE / DN 8 TO DN 50

### END CONNECTIONS SW, T, BW

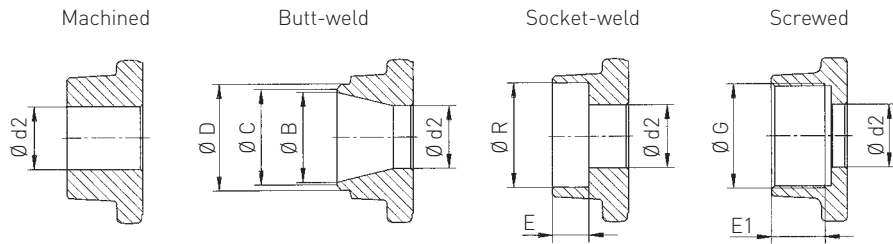

### NOTES

All the end connections are machined from the basic unmachined forged connectors.  
This technology allows quick response to the customers demand and a large variety of special connections.

### END CONNECTIONS - MAIN DIMENSIONS mm

V16 Type DN	Unmachined H d 2	Butt-weld			Socket-weld			Screwed			
		B	T C	D	E	F R	BSP		NPT		
							G	E 1	G	E 1	
8	8	8.0	10.0	13.5	9.5	13.7	1/4"	11.0	1/4"	10.5	
10	11						3/8"	11.5	3/8"	10.0	
12	11	11.0	13.5	17.2	9.5	17.5	3/8"	11.5	3/8"	10.5	
15	14	16.0	17.0	21.3	9.5	21.6	1/2"	15.0	1/2"	13.5	
20	18	21.6	23.0	26.9	11.0	27.2	3/4"	16.5	3/4"	14.0	
25	25	27.2	30.0	33.7	12.5	34.0	1"	19.0	1"	17.5	
32	30	35.9	39.0	42.4	14.5	42.8	1 1/4"	21.5	1 1/4"	18.0	
40	40	41.8	45.0	48.3	16.0	48.8	1 1/2"	21.5	1 1/2"	18.5	
50	50	53.0	56.0	60.3	17.5	60.8	2"	26.0	2"	19.5	

### PRESSURE - TEMPERATURE RATING

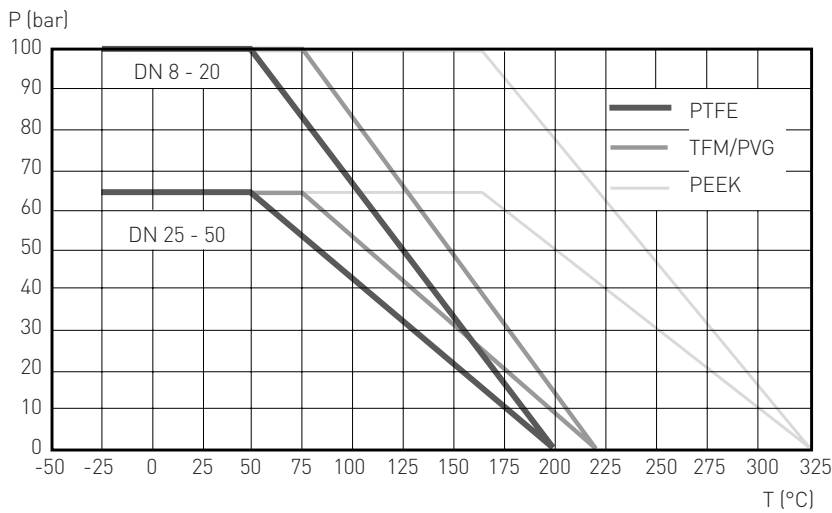

### NOTES

#### Standards seats:

- 25% glass reinforced PTFE DN 8 to DN 40. PTFE : DN 50.

#### Optional seats:

- TFM/PVG (carbon reinforced PTFE)
- PEEK (carbon reinforced)

Other seat materials (on request):

- PE Cryogenic and nuclear application
- Expanded graphite - high temperature applications

Other seat designs (on request):

Pressure relieving seats: TFM and PVG

### STANDARD PACKING AND BODY GASKET

- Temp. < 200°C  
Packing : PTFE  
Gasket : PTFE
- Temp. ≥ 200°C  
Packing : Graphite  
Gasket : Stainless steel reinforced PTFE (≤ 250°C) or graphite.
- Other packing and gasket materials upon request

### FLOW COEFFICIENT C<sub>v</sub>/K<sub>v</sub>

Welded or screwed ends							
DN	12	15	20	25	32	40	50
C <sub>v</sub>	23	29	32	94	112	245	455
K <sub>v</sub>	20	25	27	81	96	211	392
Flanged (to NFE 29-312)							
DN	15	20	25	32	40	50	
C <sub>v</sub>	26	30	71	96	210	354	
K <sub>v</sub>	22	26	61	83	181	305	

# GACHOT TYPE V16 BALL VALVES

## BRACKETS AND COUPLING FULL BORE / DN 8 TO DN 50

DN 8 - 50 PI (FB)

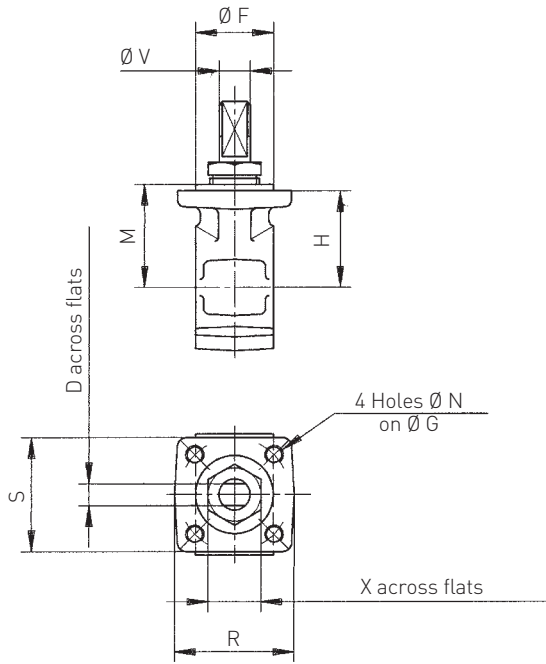

### DIMENSIONS FOR BRACKET AND COUPLING

DN	ISO	A	D	E	F	G	H	I	L	M	N	R	S	T	U	V	X
8	F03	57.0	7	10.1	25	36	28.5	38.5	39.5	30.5	M6	36.5	36.5	36.5	11	M10	17
10/12	F03	57.0	7	10.1	25	36	28.5	38.5	39.5	30.5	M6	36.5	36.5	36.5	11	M10	17
15	F03	59.5	7	10.1	25	36	31.0	41.0	42.0	33.0	M6	36.5	36.5	42.9	11	M10	17
20	F04	69.5	7	12.1	30	42	38.5	48.5	51.5	40.5	M6	42.0	42.0	51.4	11	M12	19
25	F04	72.0	7	12.1	30	42	44.0	54.5	56.0	46.0	M6	42.0	42.0	61.9	9	M12	19
32	F05	81.0	7	13.8	35	50	50.5	62.0	64.0	53.5	M6	50.0	50.0	70.0	10	M14	24
40	F05	96.5	7	15.8	35	50	63.0	75.5	76.5	66.0	M6	50.0	50.0	88.5	12	M16	30
50	F07	118.5	12	19.75	55	70	60.5	81.0	90.5	63.5	M8	67.0	71.5	103.5	16	M20	/

### TESTING

- All our valves are standard tested according to the Gachot quality assurance manual: 100% for the flanged and threaded valves, 10% for the welded end valves.

### ACCEPTANCE CRITERIA

NFE-29311 - ISO 5208 - DIN 3230

- Hydrostatic shell test: 1.5 x Pressure rating (ambient temperature). No visible leakage.
- Air seat test: 6 bar air (air in the valve body). No bubbles accepted.

### MODULAR SYSTEM

Between the same flanges can be mounted:

- V16 check valve
- V16 strainer
- V16 sight glass
- V16 3-way valve (L or T port)

### OPTIONS

- Heating jacketed V16
- Limit switch kit
- Tank bottom V16 valve
- Cryogenic V16
- Other connections and levers
- Padlocking kit

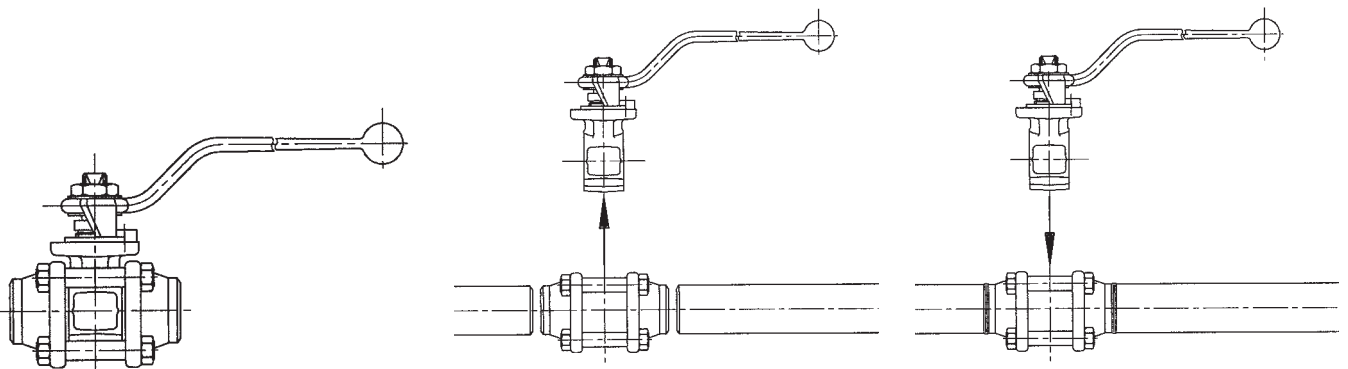

### WELDED CONNECTIONS V16 - PIPING INSTALLATION

- When the ball valve body has been removed (by just loosening the bolt nuts), the flanges set up a rigid cage easy to weld.
- Once the welding is finished, just pull the two flanges apart, insert the body between the flanges and tighten back the nuts.
- The V16 is ready to operate.

# GACHOT TYPE V16 BALL VALVES

## ACTUATOR SELECTION FULL BORE / DN 8 TO DN 50

### TORQUE VALUES FOR STANDARD SEATS/Nm

DN	Standard seats ΔP			Pressure relieving seats ΔP			Stem limiting torque (Nm)
	7	16	25	7	16	25	
8	8	9	12	8	9	12	45
15	9	10	15	9	10	15	45
20	10	12	16	10	12	16	66
25	14	17	20	14	17	20	66
32	20	25	30	20	25	30	94
40	35	40	45	30	38	45	138
50	40	50	65	35	45	65	309

Torques measured with water 1cPo viscosity at 20°C

Other seats: TFM/Carbon PTFE: +20%; PEEK DN 8 to 32: +40%, DN 40 to 50: +30%

Other packing gland: graphite packing: +10%

### ACTUATION AND CONTROL

#### Actuation

- Pneumatic double acting and single acting actuators.
- Electric actuators.
- Electric actuators for special applications.

#### Control

- Various control devices (spool valves, limit switch box).
- Pneumatic, electro-pneumatic and intelligent positioners.

### SELECTION OF PNEUMATIC ACTUATORS SERIES 79/D FOR STANDARD SEATS (APPLICATION I)

DN	Air supply (bar)	Double acting actuator ΔP (bar)				Single acting actuator ΔP (bar)			
		7	16	25	50	7	16	25	50
8	4	003	003	003	003	006S-2.7	006S-2.7	006S-2.7	012S-2.7
	6	003	003	003	003	003S-5.5	003S-5.5	006S-3.4	006S-5.5
	8	003	003	003	003	003S-5.5	003S-5.5	003S-6.9	006S-5.5
10	4	003	003	003	003	006S-2.7	006S-2.7	006S-2.7	012S-2.7
	6	003	003	003	003	003S-5.5	003S-5.5	006S-3.4	006S-5.5
	8	003	003	003	003	003S-5.5	003S-5.5	003S-6.9	006S-5.5
15	4	003	003	003	006	006S-2.7	006S-2.7	012S-2.7	012S-2.7
	6	003	003	003	003	003S-5.5	003S-5.5	006S-5.5	006S-5.5
	8	003	003	003	003	003S-5.5	003S-5.5	006S-5.5	006S-5.5
20	4	003	003	003	006	006S-2.7	006S-2.7	012S-2.7	012S-3.4
	6	003	003	003	003	003S-5.5	006S-3.4	006S-5.5	012S-3.4
	8	003	003	003	003	003S-5.5	003S-6.9	006S-5.5	006S-6.9
25	4	003	003	006	006	012S-2.7	012S-2.7	012S-3.4	024S-2.7
	6	003	003	003	003	006S-3.4	006S-5.5	006S-5.5	012S-4.1
	8	003	003	003	003	006S-3.4	006S-5.5	006S-5.5	012S-4.1
32	4	006	006	006	012	012S-3.4	012S-2.7	024S-2.7	024S-2.7
	6	003	003	006	006	006S-5.5	012S-2.7	012S-4.1	012S-5.5
	8	003	003	003	006	006S-5.5	006S-6.9	012S-4.1	012S-5.5
40	4	006	012	012	012	024S-2.7	024S-2.7	024S-3.4	036S-3.4
	6	006	006	006	012	012S-5.5	012S-5.5	024S-3.4	024S-4.1
	8	003	006	006	006	012S-5.5	012S-5.5	012S-6.9	024S-4.1
50	4	012	012	012	024	024S-2.7	024S-3.4	036S-3.4	065S-2.7
	6	006	006	012	012	012S-5.5	024S-3.4	024S-4.1	036S-5.5
	8	006	006	006	012	012S-5.5	012S-6.9	024S-4.1	024S-6.9

**Application I:** Water and waterlike fluids, temperature 20°C to 120°C standard service. Seat material DN 10 to 40: PTFE + 25% glass, DN 50: PTFE.

# GACHOT TYPE V16 BALL VALVES

## ACTUATOR SELECTION FULL BORE / DN 8 TO DN 50

### SELECTION OF PNEUMATIC ACTUATORS SERIES 79/D FOR STANDARD SEATS (APPLICATION II)

DN	Air supply (bar)	Double acting actuator ΔP (bar)				Single acting actuator ΔP (bar)			
		7	16	25	50	7	16	25	50
8	4	003	003	003	006	006S-2.7	006S-2.7	012S-2.7	012S-2.7
	6	003	003	003	003	003S-5.5	006S-2.7	006S-5.5	006S-5.5
	8	003	003	003	003	003S-5.5	003S-6.9	006S-5.5	006S-5.5
10	4	003	003	003	006	006S-2.7	006S-2.7	012S-2.7	012S-2.7
	6	003	003	003	003	003S-5.5	006S-2.7	006S-5.5	006S-5.5
	8	003	003	003	003	003S-5.5	003S-6.9	006S-5.5	006S-5.5
15	4	003	003	003	006	006S-2.7	006S-2.7	012S-2.7	012S-2.7
	6	003	003	003	003	006S-2.7	006S-3.4	006S-5.5	012S-2.7
	8	003	003	003	003	003S-6.9	003S-6.9	006S-5.5	006S-6.9
20	4	003	003	003	006	006S-2.7	012S-2.7	012S-2.7	024S-2.7
	6	003	003	003	003	006S-3.4	006S-5.5	006S-5.5	012S-4.1
	8	003	003	003	003	003S-6.9	006S-5.5	006S-5.5	006S-8.2
25	4	003	006	006	006	012S-2.7	012S-3.4	012S-3.4	024S-2.7
	6	003	003	003	006	006S-5.5	006S-5.5	012S-3.4	012S-5.5
	8	003	003	003	003	006S-5.5	006S-5.5	006S-6.9	012S-5.5
32	4	006	006	006	012	012S-3.4	024S-2.7	024S-2.7	024S-3.4
	6	003	006	006	006	012S-3.4	012S-4.1	012S-5.5	024S-3.4
	8	003	003	003	006	006S-6.9	012S-4.1	012S-5.5	012S-6.9
40	4	012	012	012	012	024S-3.4	024S-3.4	036S-3.4	065S-2.7
	6	006	006	006	012	012S-5.5	024S-3.4	024S-4.1	036S-4.2
	8	006	006	006	006	012S-5.5	012S-6.9	012S-6.9	024S-5.5
50	4	012	012	024	024	024S-3.4	036S-3.4	065S-2.7	065S-2.7
	6	006	012	012	024	024S-3.4	024S-4.1	036S-4.2	065S-2.7
	8	006	006	012	012	012S-6.9	024S-4.1	024S-5.5	036S-6.9

**Application II:** Dry fluids, high viscosity liquids, steam, oxygen service, heavy duty service or safety service, high temperature service > 120°C.

Seat material DN 10 to 40: PTFE + 25% glass, DN 50: PTFE

# GACHOT TYPE V16 BALL VALVES

MATERIALS FULL BORE / DN 65 TO DN 150

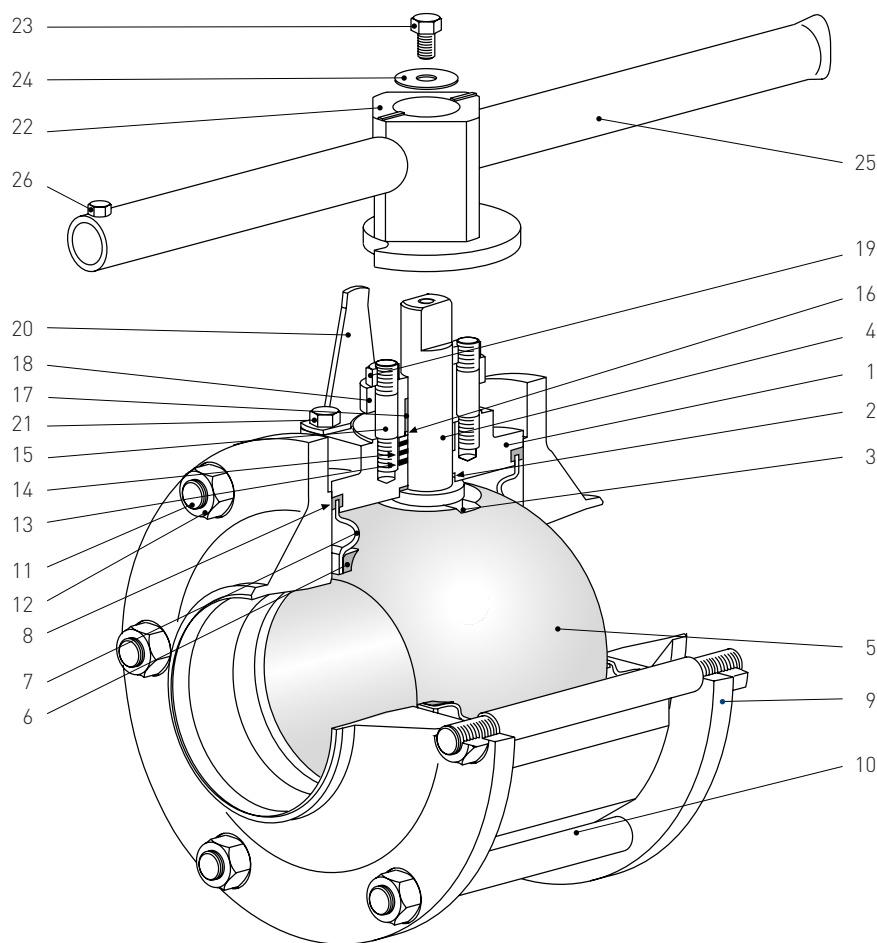

STEM GUIDE DESIGN FOR DN 150

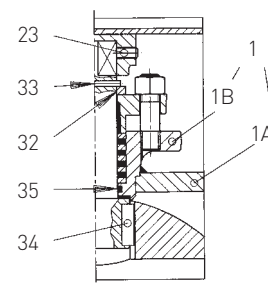

LOWER SHAFT FOR DN 150

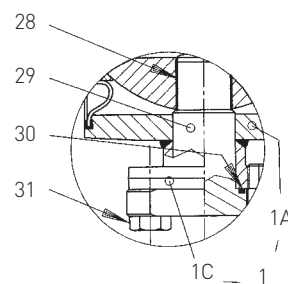

## PARTS LIST

Item	Qty	Description	Material	Item	Qty	Description	Material
1	1	Body		15	2	Gland stud	AISI 316L
1A	1	Body DN 65 to DN 100	ASTM A 105 (forged)	16	1	Spring wire DN 65 to DN 100	AISI 316
		DN 150	AFNOR A 37	17	1	Gland ring	PTFE
1B	1	Gland support DN 150	AISI 1023	18	1	Gland	ASTM A 105 (forged)
1C	1	Ball guide support DN 150	AISI 1023	19	2	Gland nut	AISI 304
2	1	Friction washer	PTFE	20	1	Travel stop	Steel
3	1	Antistatic spring DN 65 to 100	AISI 316	21	1	Stop screw	Steel
4	1	Stem	AISI 316L	22	1	Lever cap	Malleable iron
5	1	Ball	AISI 410 <sup>[1]</sup>	23	1	Screw lever	Cadmium plated steel
6	2	Seat	PTFE <sup>[2]</sup>	24	1	Washer DN 65 to DN 100	Cadmium plated steel
7	2	Seat support DN 65 to DN 100	AISI 316L	25	1	Lever	Steel
		DN 150	AFNOR A 37	26	1	Screw DN 65 to DN 100	Cadmium plated steel
8	2	Body gasket	PTFE <sup>[2]</sup>	27	1	Stop washer DN 150	AISI 316L
9	2	Flanged end connector		28	1	Guide ball ring DN 150	PTFE
9A	2	End connector	ASTM A 105 (forged)	29	1	Ball guide DN 150	AISI 316L
9B	2	Flange	ASTM A 105 (forged)	30	1	Gasket DN 150	PTFE
10	4/8	Shouldered tie bolt	5.6 ISO 898-1 <sup>[3]</sup>	31	2	Screw DN 150	AISI 304
11	2/0	Tie bolt	5.6 ISO 898-1 <sup>[3]</sup>	32	1	Washer DN 150	AISI 316L
12	12/16	Nut	CL.8 Steel cadmium p <sup>[2]</sup>	33	1	Pin DN 150	AISI 302/304
13	3/4	Soft gland washer	PTFE <sup>[3]</sup>	34	1	Key DN 150	AISI 316L
14	4/5	Metallic gland washer	AISI 316L <sup>[3]</sup>	35	1	Gasket DN 150	Viton

All indicated materials are equivalent standard designations.

1. Ball of 316L upon request
2. Other materials upon request
3. x/. for DN 65 to DN 100 FB  
.y for DN 150 FB



# GACHOT TYPE V16 BALL VALVES

DIMENSIONS FULL BORE / DN 65 TO DN 150

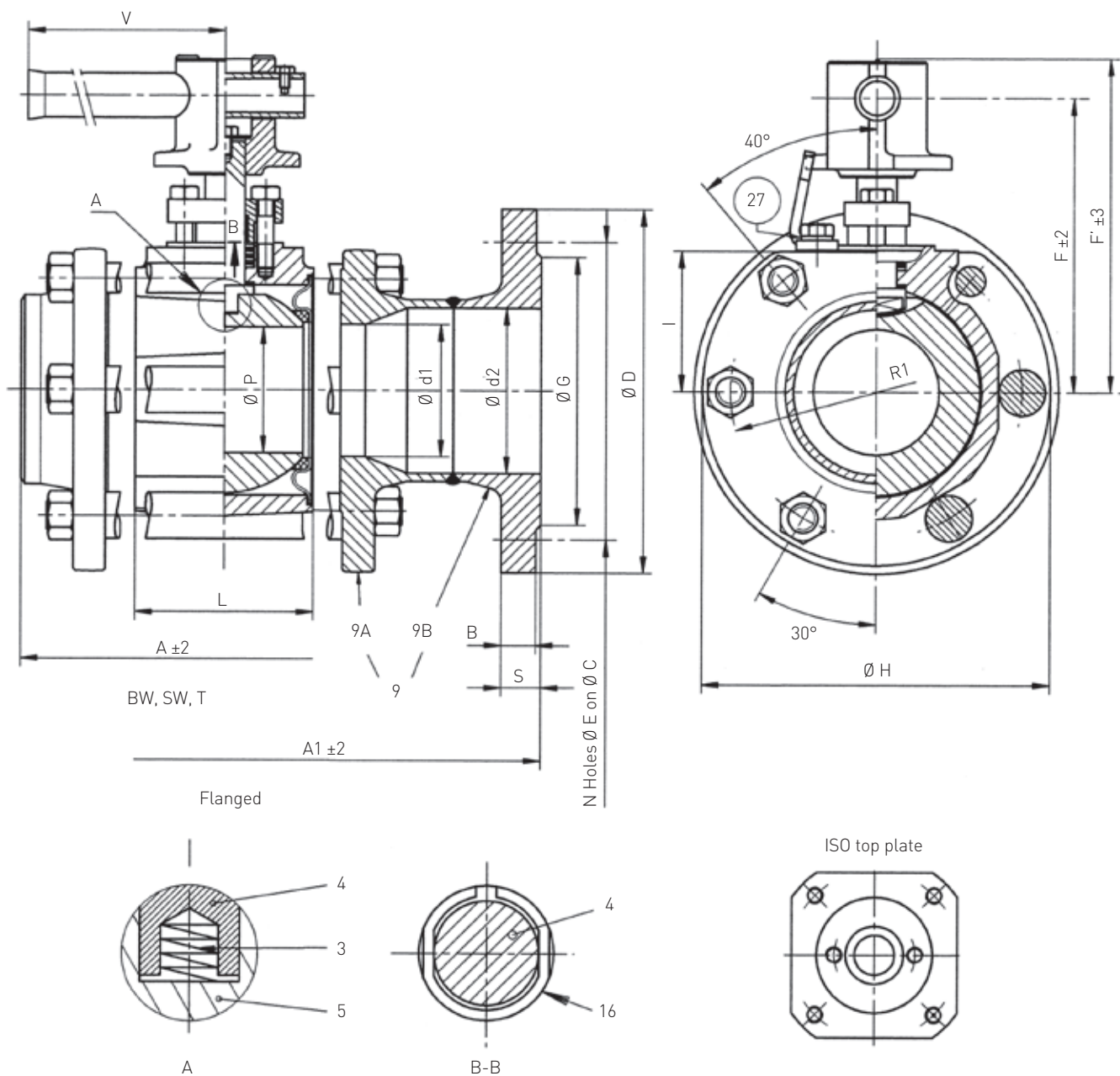

## VALVE DIMENSIONS (mm)

DN	ISO	A	A1	B	C	D	d1	d2	E	F	F'	G	H	I	L	N	P	R1	S	V	Weight (kg)	
																					Flanged	BW
65	F10	230	290	15	145	185	65	70.3	18	173	197	122	190	80	100	4	65	79.5	20	500	21	26.5
80	F10	245	310	17	160	200	80	82.5	18	178	202	138	210	85	107.5	8	76	88	22	500	26	37
100	F10	258	350	17	180	220	100	107.1	18	199	223	158	278	/	134.5	8	101	115	22	500	62	53
150	F12	419	480	19	240	285	150	159.3	22	253	287	212	340	/	193	8	150	150	24	1170		

Standard flanges to PN 16, Ra 6.3 facing. On request: flanges ANSI 150, ANSI 300, PN 25-PN40.

# GACHOT TYPE V16 BALL VALVES

## END CONNECTIONS AND RATINGS FULL BORE / DN 65 TO DN 150

END CONNECTIONS SW, T, BW

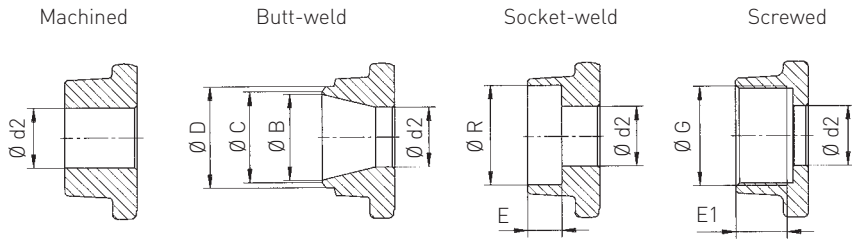

### NOTES

All the end connections are machined from the basic unmachined forged connectors. This technology allows quick response to the customers demand and a large variety of special connections.

### END CONNECTIONS - MAIN DIMENSIONS mm

V16 Type DN	Unmachined H d 2	Butt-weld			Socket-weld			Screwed			
		B	C	D	E	F	R	BSP		NPT	
								G	E 1	G	E 1
65	65	68.8	72.0	76.1	19.0		76.6	2½"	30.5	2½"	29.0
80	80	82.5	84.5	88.9	20.5		89.5	3"	33.5	3"	30.5
100	100	105.3	107.5	114.3	20.5		114.9	4"	39.5	4"	33.0
150	150	159.3	161.5	168.3	20.5		168.9				

### PRESSURE - TEMPERATURE RATING

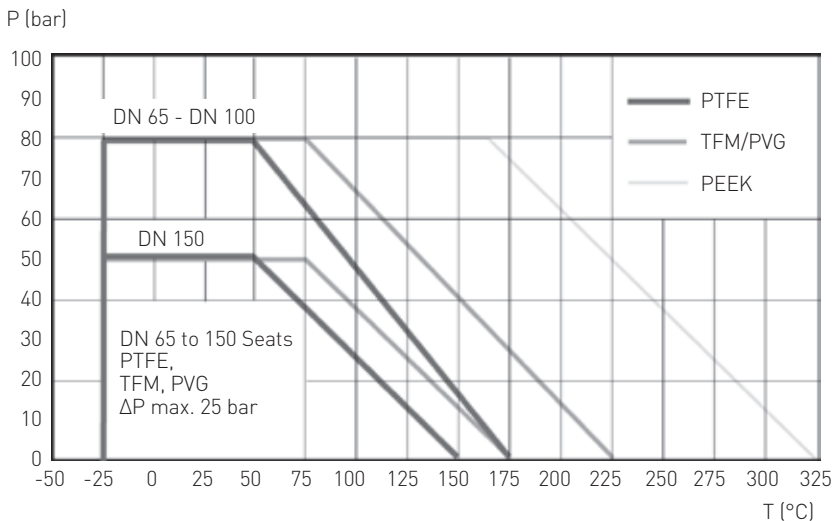

### STANDARD PACKING AND BODY GASKET

- Temp. < 200°C  
Packing : PTFE  
Gasket : PTFE
- Temp. ≥ 200°C  
Packing : Graphite  
Gasket : Stainless steel reinforced PTFE (≤ 250°C) or graphite.
- Other packing and gasket materials upon request

### NOTES

#### Standards seats:

- PTFE

#### Optional seats:

- TFM/PVG (carbon reinforced PTFE)
- PEEK (carbon reinforced)

Other seat materials (on request):

- PE Cryogenic and nuclear application
- Expanded graphite - high temperature applications

Other seat designs (on request):

Pressure relieving seats: TFM and PVG

### FLOW COEFFICIENT C<sub>v</sub>/K<sub>v</sub>

Welded or screwed ends			
DN	65	80	100
C <sub>v</sub>	795	1350	2350
K <sub>v</sub>	685	1164	2026
Flanged (to NFE 29-312)			
DN	65	80	100
C <sub>v</sub>	785	1560	2716
K <sub>v</sub>	677	1345	2340

# GACHOT TYPE V16 BALL VALVES

## BRACKETS AND COUPLING FULL BORE / DN 65 TO DN 150

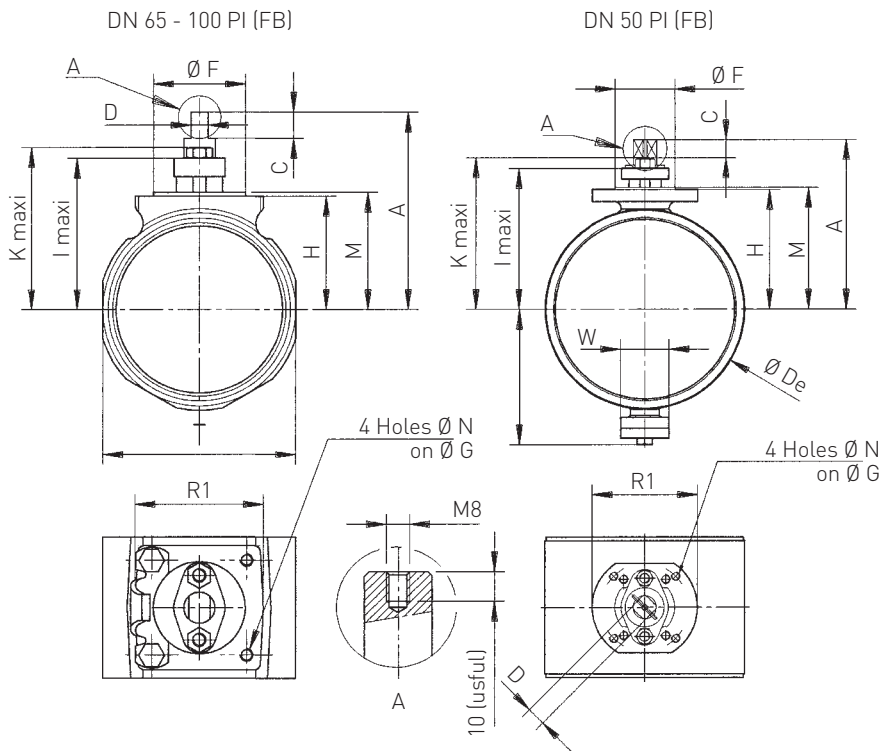

### DIMENSIONS FOR BRACKET AND COUPLING

DN	ISO	A	C	D	De	F	G	H	H1	I	K	M	N	R1	T	W
65	F10	145.0	20	16	/	70	102	82.5	/	112	121	85.5	M10	94.5	136	/
80	F10	150.0	20	16	/	70	102	86.0	/	116	125	89.0	M10	94.5	147	/
100	F10	170.5	20	16	/	70	102	108.0	/	137	146	111.0	M10	93.0	191	/
150	F12	233.0	25	26	275	85	125	165.0	186	194	208	168.0	M12	150.0	/	65

### TESTING

- All our valves are standard tested according to the Gachot quality assurance manual: 100% for the flanged and threaded valves, 10% for the welded end valves.

### ACCEPTANCE CRITERIA

- According to:  
NFE-29311 - ISO 5208 - DIN 3230
- Hydrostatic shell test: 1.5 x Pressure rating (ambient temperature). No visible leakage.
  - Air seat test: 6 bar air (air in the valve body). No bubbles accepted.

### MODULAR SYSTEM

Between the same flanges can be mounted:

- V16 check valve
- V16 strainer
- V16 sight glass
- V16 3-way valve (L or T port)

### OPTIONS

- Heating jacketed V16
- Limit switch kit
- Tank bottom V16 valve
- Cryogenic V16
- Other connections and levers
- Padlocking kit

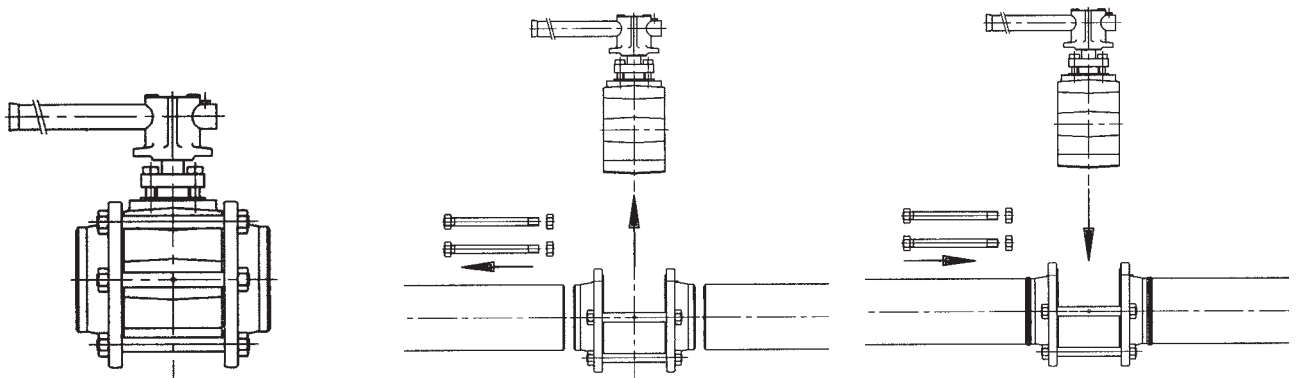

### WELDED CONNECTIONS V16 - PIPING INSTALLATION

- When the ball valve body has been removed (by just loosening the bolt nuts and removing the two upper stud bolts or the four upper stud bolts for DN 150), the flanges set up a rigid cage easy to weld.
- Once the welding is finished, just pull the two flanges apart, insert the body between the flanges, refit the upper stud bolts and tighten back the nuts.
- The V16 is ready to operate.

# GACHGACHOT TYPE V16 BALL VALVES

## ACTUATOR SELECTION FULL BORE / DN 65 TO DN 150

### TORQUE VALUES FOR STANDARD SEATS/Nm

DN	Standard seats ΔP			Pressure relieving seats ΔP			Stem limiting torque (Nm)
	7	16	25	7	16	25	
65	90	105	130	78	105	130	615
80	105	130	160	95	130	160	615
100	140	190	230	120	190	230	615
150	-	-	-	-	-	-	-

Torques measured with water 1cPo viscosity at 20°C

Other seats: TFM/Carbon PTFE: +20%; PEEK +30%

Other packing gland: graphite packing: +10%

### ACTUATION AND CONTROL

#### Actuation

- Pneumatic double acting and single acting actuators.
- Electric actuators. Double acting and single acting spring return.
- Electric actuators for special applications.

#### Control

- Various control devices (spool valves, limit switch box).
- Pneumatic, electro-pneumatic and intelligent positioners.

### SELECTION OF PNEUMATIC ACTUATORS SERIES 79/D FOR STANDARD SEATS

DN	Air supply (bar)	Double acting actuator ΔP (bar)				Single acting actuator ΔP (bar)			
		7	16	25	50	7	16	25	50
<b>I*</b>									
65	4	024	024	024	-	065S-2.7	065S-2.7	065S-2.7	-
	6	012	012	024	-	036S-5.5	036S-5.5	065S-2.7	-
	8	012	012	012	-	024S-5.5	024S-6.9	036S-6.9	-
80	4	024	024	036	-	065S-2.7	065S-2.7	090S-3.4	-
	6	012	024	024	-	036S-5.5	065S-2.7	065S-5.5	-
	8	012	012	024	-	024S-6.9	036S-6.9	065S-5.5	-
100	4	024	036	065	-	090S-3.4	090S-3.4	090S-4.1	-
	6	024	024	036	-	065S-4.1	090S-3.4	090S-5.5	-
	8	012	024	024	-	036S-6.9	065S-5.5	065S-6.9	-
<b>II*</b>									
65	4	024	024	036	-	065S-2.7	065S-2.7	090S-3.4	-
	6	012	024	024	-	036S-5.5	065S-2.7	065S-4.1	-
	8	012	012	024	-	036S-5.5	036S-6.9	065S-4.1	-
80	4	024	036	036	-	065S-2.7	090S-3.4	090S-4.1	-
	6	024	024	024	-	065S-2.7	065S-4.1	090S-3.4	-
	8	012	024	024	-	036S-6.9	065S-4.1	065S-5.5	-
100	4	036	065	065	-	090S-3.4	090S-4.1	*****	-
	6	024	036	036	-	090S-3.4	090S-5.5	*****	-
	8	024	024	024	-	065S-5.5	065S-6.9	090S-3.4	-

### NOTES

**Application I:** Water and waterlike fluids, temperature 20°C to 120°C standard service. Seat material PTFE.

**Application II:** Dry fluids, high viscosity liquids, steam, oxygen service, heavy duty service, high temperature service > 120°C. Seat material PTFE.

These products have been designed, manufactured and tested under the supervision of an ISO 9001-2000 certified Quality Assurance system complying with:

- module H (categories I, II and III) of annex 3 of European Directive 97/23/EC concerning pressure equipment,
- module H (categories 1, 2) of European Directive 1999/36/EC concerning transportable pressure equipment;

and ensuring the products meet the safety and health essential requirements for the design and manufacturing of equipment intended for use in potentially explosive atmospheres according to the ATEX Directive 94/9/EC.



### PENTAIR VALVES & CONTROLS

[www.pentair.com/valves](http://www.pentair.com/valves)

All Pentair trademarks and logos are owned by Pentair Ltd. All other brand or product names are trademarks or registered marks of their respective owners. Because we are continuously improving our products and services, Pentair reserves the right to change product designs and specifications without notice. Pentair is an equal opportunity employer. © 2012 Pentair Ltd. All rights reserved.