

## KEYSTONE RMI HYDRAULIC CONTROLLED BUTTERFLY/CHECK VALVE

The hydraulic controlled butterfly check valve is suitable as pump and pipe line protection

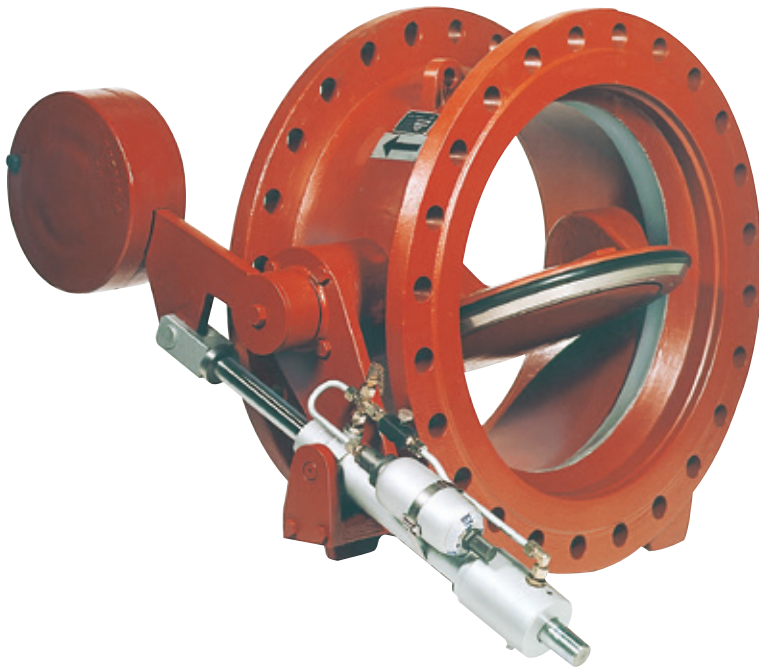

### FEATURES

- Triple eccentric design
- Resilient seated type (zero leakage) seal on disc, replaceable and adjustable
- Available in metal-to-metal seating with stainless steel to bronze seating
- Leak rate D according BS 6755, or better
- One piece seal retaining ring
- Low head loss
- Face-to-face dimension available to different standards
- Flanges according to all international standards
- Complete with lever and counterweight
- Complete with hydraulic 2-step damping cylinder
- Available with add-on power packs suitable to meet your operational needs

### GENERAL APPLICATION

Suitable as pump and pipe line protection valve in drinking water systems.

### TECHNICAL DATA

Pressure (bar):	2.5/4/6/10/16
Back pressure (bar):	standard up to 4 bar*
Temperature (°C):	-20 to +80
Sizes (mm):	200 - 2400**
Flange accommodation:	ISO flange (standard); other international standards on request

\* Contact factory for maximum back pressure at larger sizes

\*\* Larger sizes on request



# KEYSTONE RMI HYDRAULIC CONTROLLED BUTTERFLY/CHECK VALVE

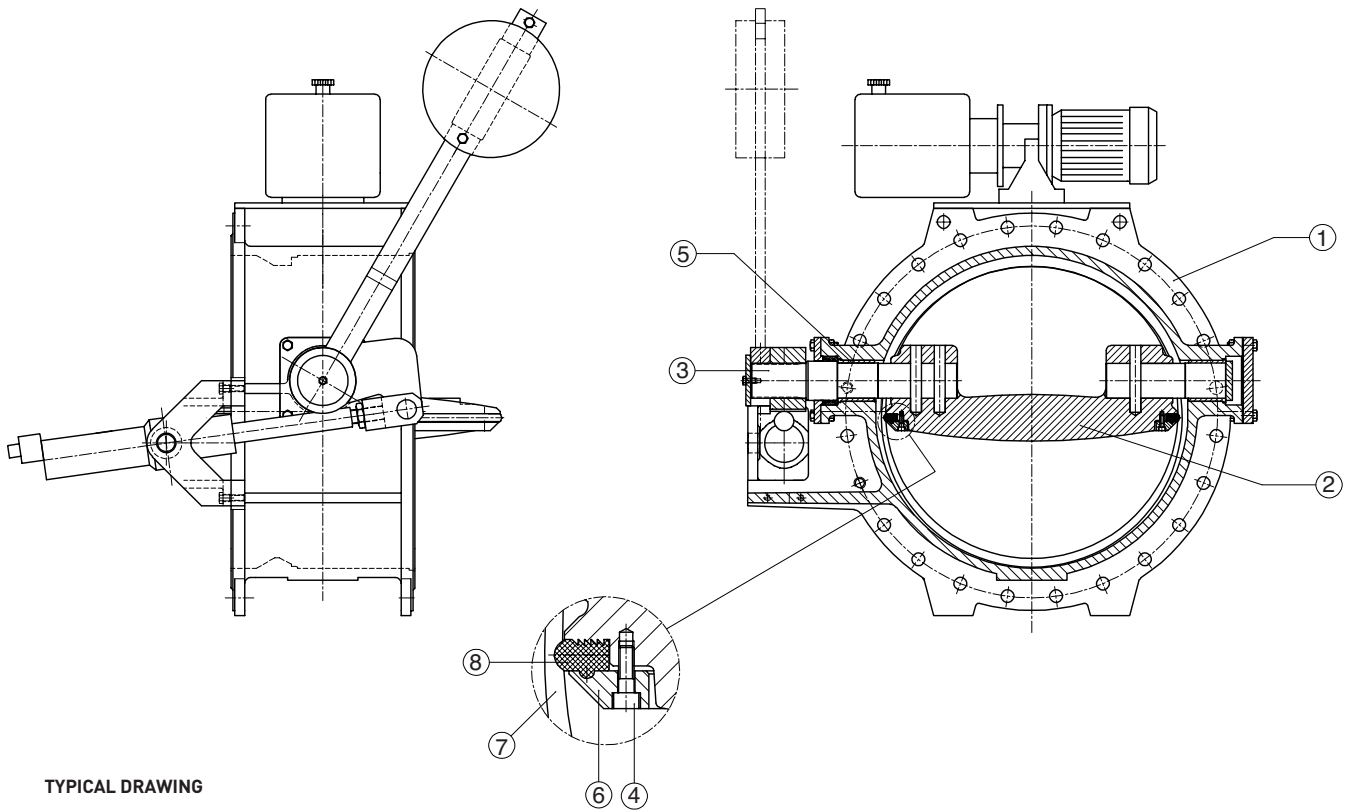

TYPICAL DRAWING

Materials	
Body	Ductile cast iron
Disc	Ductile cast iron
Stub Shafts	Stainless steel
Adjustable bolts	Stainless steel
Bearings	Self-lubricating
For resilient seated type	
Retaining-ring	Stainless steel or Ductile iron
Body seat	Stainless steel or Epasfill; rubber lined
Disc seal	Nitrile
For metal-to-metal seated type	
Body seat	Stainless steel
Disc seal	Bronze

## PARTS LIST

Part	Name
1	Body
2	Disc
3	Stub shafts
4	Adjusting bolt
5	Bearings
6	Retaining-ring
7	Body seat
8	Disc seal

Alternative materials, as well as special linings and coatings: on request

## OPERATION

### Hydraulic controlled butterfly/check valve

**Opening** Valve is opened by the flow. Opening angle is depending on pressure/flow/velocity

**Closing** Valve will close when the flow will decrease under influence of the counterweight. The hydraulic cylinder will control the closing speed of the valve. The closing time is adjustable, depending on customer specifications.

### Hydraulic controlled butterfly valve with add-on pack

**Opening** Valve starts opening by the flow. Once a certain pre-set opening angle is reached (e.g. 20°), the motor of the add-on pack is activated by a limit switch and the valve is opened 100% by the hydraulic cylinder.

# KEYSTONE RMI HYDRAULIC CONTROLLED BUTTERFLY/CHECK VALVE

## TYPICAL DIAGRAM

