

Pressure seal gate valve designs, suitable for the arduous services and high temperatures encountered in power industry applications.

Features

- A range of compact pressure seal gate valves designed according to ASME B16.34.
- All range is offered in four standard cast materials: WCB (generally used on feed water lines), WC6 and WC9 (both used on steam lines), C12A (proposed for high temp. applications).
- End to end dimensions as per ASME B16.10 short pattern.
- Available in wedge gate and parallel slide configurations.
- Seats are welded in.
- Position indicator is offered as standard.
- Stellite® gr. 6 overlay on seat and wedge or disc; Stellite® gr. 21 overlay on backseat.
- Pressure seal gasket has trapezoidal shape for a low load on bolting, and is supplied in graphite with integral stainless steel anti-extrusion protection.
- Standard ISO top mounting for easy assembly of any type of actuator or bevel gear.
- Available options: wedge vent hole or overpressure pipe, by-pass, limit switch in open or closed position.



Technical data

Pressure ratings	: ASME classes 900 to 2500
Body materials	: A216 WCB, A217 WC6, A217 WC9, A217 C12A
Temperature (°C)	: -46 to +650
Sizes (mm)	: 50 to 600 (2"-24")
Connections standards	: ASME B16.25

General application

Our pressure seal -Style A- gate valves are recommended for several applications in the power industry, in particular in feed water lines, steam lines, and in services which involve high temperatures media.

Pressure Seal Cast Gate Valves -Style A- Wedge Gate and Parallel Slide

Wedge Gate Configuration

Fig. 1

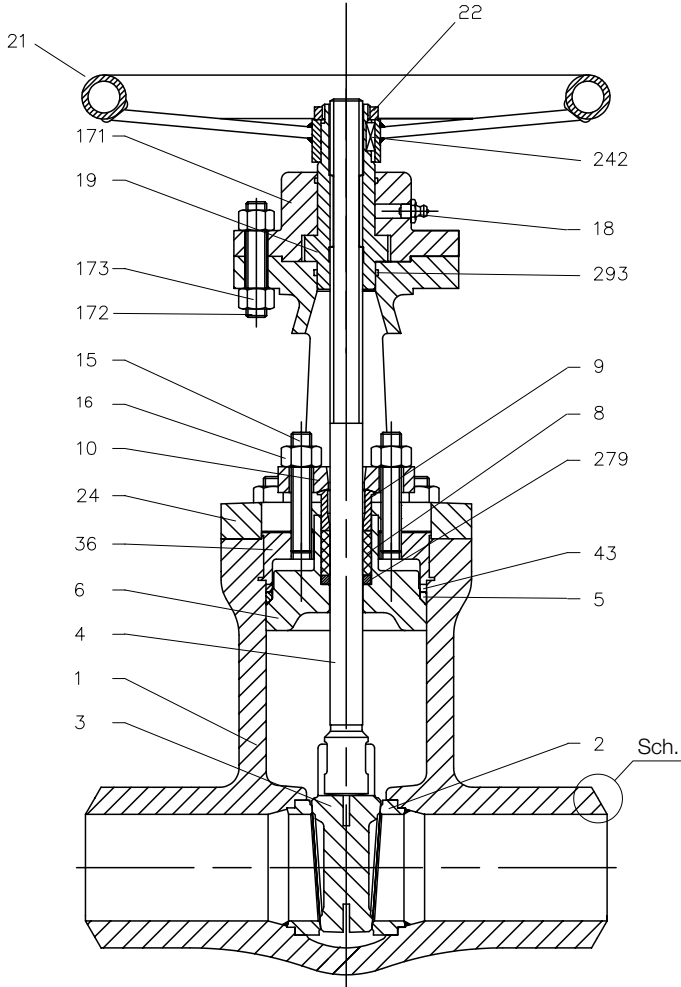

Parallel Slide Configuration

Fig. 2

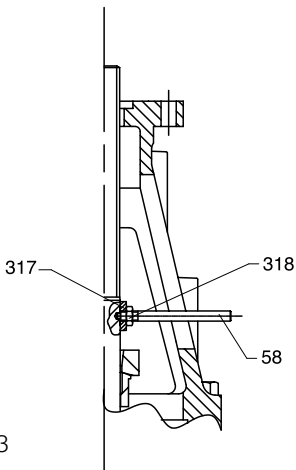
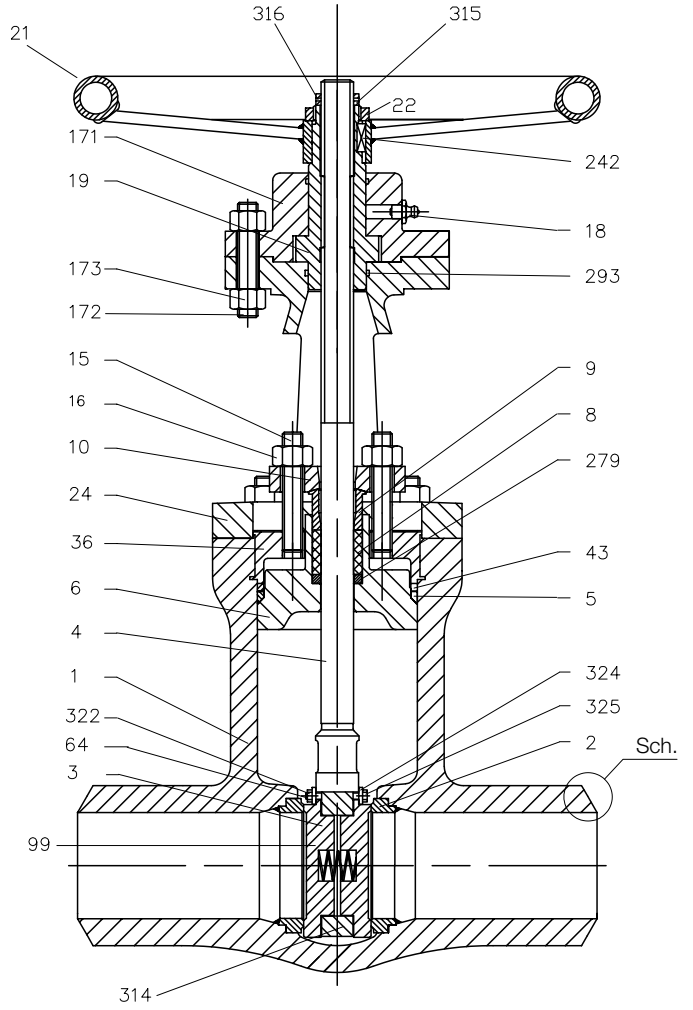

Fig. 3

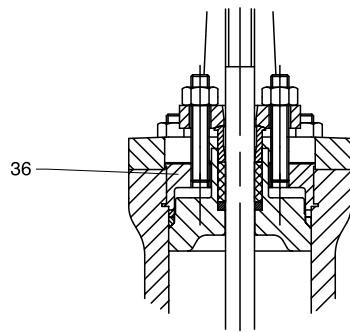

Fig. 4

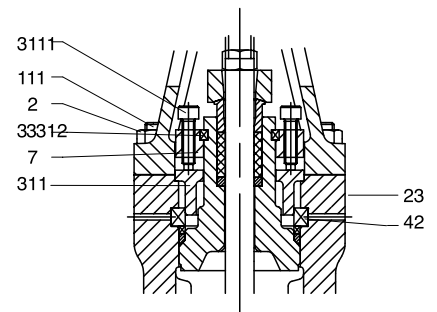

Fig. 5

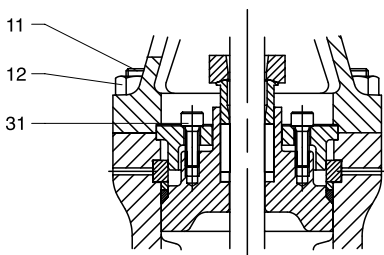

Fig. 6

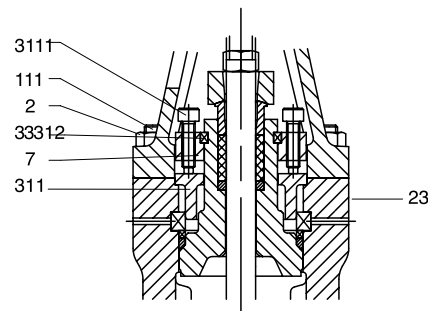

Fig. 7

Notes

1. Fig. 4 is applicable for DN 2" and 2"1/2 only.
2. Fig. 5 is applicable for DN 3" only.
3. Fig. 6 is applicable for DN from 4" to 24" (ASME cl. 900 & 1500), and for DN from 12" to 24" (ASME cl. 2500).
4. Fig. 7 is applicable for DN from 4" to 10" (ASME cl. 2500).

Pressure Seal Cast Gate Valves -Style A-

Wedge Gate and Parallel Slide

Material specification					
Ref	Description	Body Mat.: WCB	Body Mat.: WC6	Body Mat.: WC9	Notes
1	Body	A 216 WCB	A 217 WC6	A 217 WC9	
2	Seat	A 105 + Stellite gr. 6	A 182 F22 + Stellite gr. 6	A 182 F22 + Stellite gr. 6	1
3	Wedge (for wedge gate conf.)	A 216 WCB + Stellite gr. 6	A 217 WC9 + Stellite gr. 6	A 217 WC9 + Stellite gr. 6	2
3	Disc (for parallel slide conf.)	A 105 + Stellite gr. 6	A 182 F22 + Stellite gr. 6	A 182 F22 + Stellite gr. 6	2
4	Stem	A 182 F6a Cl 2	A 565 gr 616HT	A 565 gr 616HT	
5	Gasket	316 reinforced graphite	316 reinforced graphite	316 reinforced graphite	
6	Bonnet	A 105 + Stellite gr. 21	A 182 F22 + Stellite gr. 21	A 182 F22 + Stellite gr. 21	
8	Packing	Graphite	Graphite	Graphite	
9	Gland	A 182 F6a Cl 2	A 182 F6a Cl 2	A 182 F6a Cl 2	
10	Gland flange	A 516 gr 70	A 516 gr 70	A 516 gr 70	
11	Body-yoke bolts	A 193 B7	A 193 B7	A 193 B16	
12	Body-yoke nuts	A 194 2H	A 194 2H	A 194 4	
15	Gland bolts	A 193 B7	A 193 B7	A 193 B16	
16	Gland nuts	A 194 2H	A 194 2H	A 194 4	
18	Lubricator	Carbon steel	Carbon steel	Carbon steel	
19	Yoke sleeve	A 763 Gr A	A 763 Gr A	A 763 Gr A	
21	Handwheel	Carbon steel	Carbon steel	Carbon steel	
22	Handwheel nut	A 105	A 105	A 105	
23	Name Plate	Stainless steel	Stainless steel	Stainless steel	
24	Yoke	A 216 WCB	A 216 WCB	A 216 WCB	
31	Bonnet screw	A 193 B7	A 193 B16	A 193 B16	
36	Bonnet retaining ring	A 105	A 182 F22	A 182 F22	3
37	Gland bolts flange	A 105	A 105	A 105	4
42	Segment ring	A 182 F22	A 182 F22	A 182 F22	5
43	Intermedia thrust ring	A 182 F22	A 182 F22	A 182 F22	
58	Position indicator	A 105	A 105	A 105	
64	Split pin	Stainless steel	Stainless steel	Stainless steel	
99	Spring	Inconel 718	Inconel 718	Inconel 718	
171	Bearings housing	A 105	A 105	A 105	
172	Coupling bolts	A 193 B7	A 193 B7	A 193 B7	
173	Coupling nuts	A 194 2H	A 194 2H	A 194 2H	
242	Key	Key steel	Key steel	Key steel	
279	Bottom ring	A 182 F6a Cl 2	A 182 F6a Cl 2	A 182 F6a Cl 2	
293	O-Ring	Viton 70 sh	Viton 70 sh	Viton 70 sh	
311	Retaining ring	A 105	A 105	A 105	6
312	Two half ring	A 182 F6a Cl 2	A 182 F6a Cl 2	A 182 F6a Cl 2	7
314	Anchor	A 216 WCB	A 217 WC9	A 217 WC9	
315	Stop ring	A 182 F6a Cl 2	A 182 F6a Cl 2	A 182 F6a Cl 2	
316	Pin	Stainless steel	Stainless steel	Stainless steel	
317	Ring	A 105	A 105	A 105	
318	Nut	A 194 2H	A 194 2H	A 194 2H	
322	Nut	A 194 8	A 194 8	A 194 8	
324	Bushing	A 182 F6a Cl 2	A 182 F6a Cl 2	A 182 F6a Cl 2	
325	Screw	A 193 B8	A 193 B8	A 193 B8	

Notes

1. Seats are welded in.
2. Flexible.
3. Applicable for DN 2" and 2 1/2" only (ASME cl. 900-1500-2500).
4. Applicable for DN 3" only (ASME cl. 900 and 1500); from DN 2" to 10" (ASME cl. 2500).
5. Applicable for DN from 3" to 24" (ASME cl 900-1500-2500).
6. Applicable for DN from 3" to 24" (ASME cl. 900 and 1500).
7. Applicable for DN 3" (cl. 900 and 1500); from DN 2" to 10" (ASME cl. 2500).

Pressure Seal Cast Gate Valves -Style A- Wedge Gate and Parallel Slide

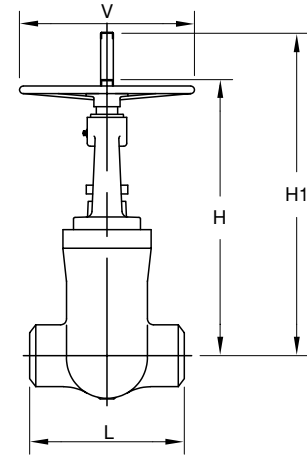
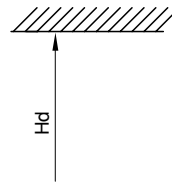
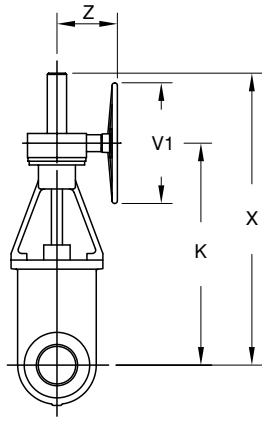
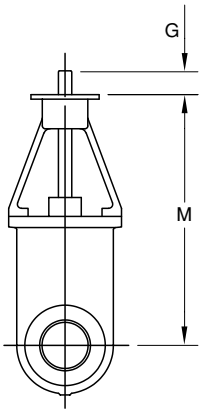

Dimensions and weights ASME Cl. 900

Size (in.)	G	M	L	Hd	H	H1	V	V1	Z	K	X	Top flange	Travel (n° turns ± 1)	Travel (mm)	Weight (bare shaft)
2	140	395	216	760	535	600	200					F10	15	63	38
2 1/2	140	395	254	760	535	600	200					F10	15	63	50
3	140	480	305	890	620	695	250					F10	18	76	55
4	150	520	356	960	665	765	300					F10	19	97	70
6	170	750	508	1335				600	350	840	1175	F14	22,5	142	175
8	180	870	660	1510				800	350	960	1295	F14	29,5	186	295
10	205	975	787	1725				800	430	1075	1435	F16	36,5	230	485
12	215	1130	914	1985				800	430	1230	1690	F25	43	273	795
14	230	1315	991	2260				800	550	1430	2000	F30	37	311	940
16	250	1465	1092	2515				800	550	1605	2150	F30	41	345	1240
18	250	1600	1143	2725				800	550	1745	2285	F35	46,5	391	1640
20	300	1740	1245	3005				800	430	2110	2495	F35	52	438	2150
24	305	2060	1397	3510				800	465	2480	2955	F40	41	517	2800

Dimensions and weights ASME Cl. 1500

Size (in.)	G	M	L	Hd	H	H1	V	V1	Z	K	X	Top flange	Travel (n° turns ± 1)	Travel (mm)	Weight (bare shaft)
2	140	395	216	760	535	600	200					F10	15	63	38
2 1/2	140	395	254	760	535	600	200					F10	15	63	50
3	140	480	305	890	620	695	250					F10	18	76	55
4	150	515	406	955	665	765	350					F14	19	95	95
6	175	745	559	1325				800	350	835	1170	F14	22	137	210
8	210	915	711	1630				800	430	1015	1375	F16	28,5	179	425
10	240	1030	864	1870				800	550	1150	1690	F25	26	220	735
12	245	1155	991	2085				800	550	1300	1840	F30	31	260	1160
14	245	1340	1067	2340				800	570	1485	2010	F35	34,5	291	1300
16	255	1465	1194	2540				800	430	1835	2120	F35	38,5	324	1750
18	255	1670	1346	2860				800	430	2040	2325	F35	30	376	2510
20	300	1840	1473	3165				800	465	2260	2635	F40	33	418	3350
24	300	2105	1943	3610				800	510	2530	3010	F48	39	490	4500

Dimensions and weights ASME Cl. 2500

Size (in.)	G	M	L	Hd	H	H1	V	V1	Z	K	X	Top flange	Travel (n° turns ± 1)	Travel (mm)	Weight (bare shaft)
2	140	385	279	780	530	585	200					F10	13	55	40
2 1/2	140	385	330	820	530	585	200					F10	13	55	50
3	155	455	368	880	610	675	250					F10	15	63	60
4	155	500	457	930				600	350	590	830	F14	15	75	110
6	175	755	610	1300				800	350	845	1180	F16	18,5	117	285
8	205	915	762	1700				800	430	1015	1375	F16	24	152	515
10	245	1110	914	2300				800	550	1250	1795	F30	23	191	1065
12	260	1205	1041	2300				800	570	1350	1890	F35	27	225	1655
14	255	1300	1118	2480				800	430	1670	1860	F35	29	245	1790
16	300	1515	1245	2840				800	465	1940	2210	F40	23	285	2550
18	300	1620	1397	3040				800	465	2040	2315	F40	25,5	319	3450
20	300	1770	1524	3270				800	510	2200	2670	F48	28	351	4650
24	390	2040	1676	3870				800	605	2550	3025	F60	33	420	6300