

# SAPAG

Contents	
<b>Important notice</b>	<b>1</b>
<b>0 Valve identification</b>	<b>2</b>
<b>1 Storage</b>	<b>2</b>
<b>2 Installation</b>	<b>2</b>
<b>3 Operation</b>	<b>2</b>
<b>4 Maintenance</b>	<b>3</b>
4.1 Dismantling	3
4.2 Inspection	4
4.3 Repair	4
4.4 Assembly	4
4.5 Setting and test	4
<b>5 In service supervision of safety valves</b>	<b>5</b>
<b>Trouble shooting</b>	<b>5</b>
<b>Positions of the nozzle ring</b>	<b>5</b>
<b>Appendix A: Parts list</b>	<b>6</b>
<b>Appendix B: Parts list</b>	<b>7</b>
<b>Appendix C</b>	<b>8</b>
Dimensions	8
Re- machining of the disc and nozzle seats	8

## **IMPORTANT NOTICE**

Do not install a SAPAG safety valve before reading and understanding the following instructions. SAPAG cannot be responsible for situations resulting from a poor knowledge by the installer or the user of the present instructions.

Each safety valve has been designed for a particular application corresponding to the information as included onto its nameplate and indicated on the test report supplied with the valve. The installer shall make sure that the safety valve he is to install is the one which has been designed for this application at this location. The tag of the safety valve must be checked and compared to its location, and the Set Pressure of the valve compared to the Design Pressure of the equipment. The Set Pressure of a safety valve as indicated on its nameplate cannot exceed the Design Pressure of the vessel on which it is installed. The Cold Differential Test Pressure as indicated on the nameplate may exceed the Design Pressure of the vessel by no more than 5%, only when the safety valve has to operate at elevated temperature.

SAPAG has delivered a safety valve corresponding to the service conditions as known when the order was registered. The materials used for the components are in accordance with SAPAG standard bills of materials. The materials have been selected together with the buyer within the various possibilities as offered by the SAPAG catalogue. For the main pressure retaining components these materials are certified in accordance with EN 10204 3.1.B.

SAPAG cannot be responsible for accelerated damages to components caused by corrosion or chemical attack by substances constituting or not the process fluid beyond reasonably foreseeable limits and provided the presence of these substances were clearly stated when the equipment was ordered.

The nature, the phase, the viscosity, the temperature of the fluid and all other relevant data taken into consideration by SAPAG are those known at the time of the request for quotation. SAPAG cannot be responsible for a safety valve operational accident resulting in the fact that one or several data wandered away from what was specified in the order.

The installation of a safety valve, as it relates to the inlet and outlet pressure drop, as well as the drainage of the exhaust piping, shall be in accordance with these instructions.

A safety valve is normally closed and should open only to overcome exceptional upset conditions. However the unexpected opening, full or partial, of a safety valve is an event that needs to be considered; the installer shall therefore connect the outlet port of the safety valve to a system allowing the flow to be piped away to an appropriate location. The installer shall consider the following dangers:

- The blast from the safety valve;
- The potential leakage from the safety valve exhaust of lethal, noxious or polluting substances;
- The temperature (elevated or cryogenic) of the exhausted fluid, and the warm-up or cool down of the connected exhaust pipe work;
- The loud noise generated by the safety valve when it opens.

The safety valves are supplied adjusted, sealed and gagged.  
IT IS MANDATORY TO REMOVE THE GAG AFTER INSTALLATION AND BEFORE USE.

The adjustments of the valves are protected by seals. Breaking the seals will engage the responsibility of the person doing it. When the seals are broken, SAPAG cannot bear any responsibility for a valve adjustment carried out without its formal agreement.

The adjustment or modification of a safety valve setting can only be performed by competent and trained personal using an appropriate test installation fitted with accurate and calibrated pressure measuring equipment.

Further to any setting modification of a safety valve, a new nameplate, showing the new setting value and the identification of the authority having performed the adjustment must be affixed onto the valve.

### 0. Valve identification

Each valve is identified by a nameplate showing, in addition to the CE mark, the following information:

- Name and address of the manufacturer: SAPAG, Armentières, France;
- Year and month of manufacture;
- Type of safety valve;
- Serial number;
- Set pressure;
- Cold Differential Test Pressure;
- Dimensions and rating of inlet and outlet connections;
- When applicable: the valve tag number.

The value of the Cold Differential Test Pressure is also stamped on the edge of the outlet flange.

The serial number of the valve is stamped on the bonnet flange edge.

### 1. Storage

The safety valves must be stored away from dust, moisture or weathering.

The valve openings are protected by taps. These taps should remain in place until the valve is installed.

The safety valve must be handled with care.

The gag on the top of the safety valve can be used as a lifting hook.

### 2. Installation

- 2.1 The vessel and the piping must be absolutely clean and free from any foreign matter before installing the safety valve.
- 2.2 The pressure drop between the protected vessel and the safety valve should not exceed 3% of the set pressure of the valve. The safety valve must be installed in the upright position, the spring on the top side.
- 2.3 The pressure drop of the exhaust piping should not exceed 10% of the set pressure if the safety valve is not fitted with a balancing bellows; this limit is extended to 50% if the valve is fitted with a balancing bellows.
- 2.4 Clean the flange on which the valve is to be installed using an appropriate solvent.
- 2.5 Check the dimensions of the ports of the safety valve in comparison to the piping connections. The inlet and outlet connections are always different the inlet NPS is smaller than the outlet NPS, so that installation of the safety valve in the wrong position is impossible.
- 2.6 Bring the valve carefully to its location.
- 2.7 Remove the port taps and clean up the flange facings with an appropriate solvent.
- 2.8 Check piping cleanness.
- 2.9 Fit the connecting gaskets and put the safety valve in position.
- 2.10 Tight the stud bolts evenly, commencing by the inlet flange.
- 2.11 Make sure that the connecting piping does not induce detrimental stresses on the safety valve body.
- 2.12 The body of the safety valve is fitted with a drain hole, closed at the factory with a plug. It is very important that the body of the valve is not continuously filled by a stagnating fluid, due to either the discharge medium, or the weather, or caused by the discharge of other pressure relieving or safety devices connected to the same header. The drain hole may be used for this purpose. It is also advisable to design the exhaust piping in such a way that the body is never filled in by a stagnating fluid.

### 3. Operation

- 3.1 The safety valve is supplied with a GAG. This GAG blocks the valve into the closed position. **WITH THE GAG IN PLACE THE SAFETY VALVE CANNOT OPEN.**
- 3.2 The safety valve must remain gagged if an hydraulic test has to be performed with the valve in place. SAPAG recommends that, whenever possible, the hydraulic test is performed without the safety valve, replacing it during the test procedure by a blank tap if it is impossible, then the hydraulic test may be performed with the safety valve in place, with its gag. The gag is normally hand tighten only excessive tightening may damage the safety valve trim.
- 3.3 After completion of the hydraulic test, and before use, **THE GAG MUST BE REMOVED AND REPLACED BY THE PLUG (21) AND THE GASKET (22) supplied with the safety valve.**

- 3.4 The set pressure tolerance is +/- 3%.  
The maximum operating pressure should not exceed 90% of the set pressure.  
The safety valve is adjusted to be tight at 90% of the set pressure.
- 3.5 The safety valves are set at ambient temperature. For elevated service temperature, a correction as per table 1 shall apply.

**Table 1: temperature correction**

Service temperature	Temperature correction
≤ 120°C (250°F)	none
121°C to 538°C (250°F to 1000°F)	+3%
> 538°C (>1000°F)	+5%

- 3.6 *Cold Differential Test Pressure change.*  
The Cold Differential Test Pressure may be changed by +/- 5% from the pressure marked on the nameplate.  
When the CDTP is to be modified it is necessary to change the marking accordingly and to affix a new nameplate showing the modified pressure value as well as the identification of the authority proceeding to the modification.  
If the CDTP has to be modified beyond above limitation, consult the factory.
- 3.7 *Use of the lifting lever.*  
If the safety valve is fitted with a lifting lever, it may be used to check periodically the valve operation.  
To check the valve operation, the pressure underneath the disc shall not be less than 75% of the set pressure.
- 3.8 *Operation failures.*  
Operation failures can be solved by applying information as per table 2.

#### 4. Maintenance

Dismantling, maintenance, assembly and setting shall be performed only by trained and skilled operators using adequate equipment and calibrated measure tools.

The guarantee provided by SAPAG covers maintained and repaired safety valves only if the components, if replaced, are either SAPAG components or components certified by SAPAG.

The safety valves returned from the site to the maintenance shop should before any maintenance routine be decontaminated by appropriate media in order to preserve the health of the operators.

After overhaul, each safety valve shall be thoroughly and individually inspected and sealed by an individual authorised by the user. The individual performing the sealing of the safety valve shall fill in the corresponding Test Report and show his identification on the inspected valve. The valve shall be identified by an additional nameplate showing the authority proceeding to the adjustment.

- 4.1 *Dismantling (see Appendix A)*
- Remove the cap (3) and gasket (23).
  - Measure and record the dimension between the top of the adjusting screw (19) and the topside of the adjusting screw nut (20).
  - Loosen the nut (20) and the adjusting screw (19).
  - Remove the bonnet bolts (18) and the bonnet (2).
  - Remove the spindle (15), the spring and its washers (26-27), the guide assembly (16-17), the disc holder assembly (14-13-9-7-8), gaskets and bellows if applicable.
  - Pull on the spindle to disconnect from disc holder.
  - Remove the disc (4) from the disc holder (9) by inserting a tool in the lateral hole in the disc holder (9); handle the disc (7) with extreme care.  
If applicable, remove the bellows as follows: the bellows is screwed onto the disc holder with a right thread. Use a spanner wrench and unscrew by turning anti clockwise.  
The wall thickness of the bellows is very thin and it must not be damaged at any time during dismantling. Remove the bellows gasket.
  - Loosen the nozzle ring screw (6) and its gasket (24).
  - Turn the nozzle ring (5) anti clockwise and remove it through the top of the body.
  - If the nozzle (4) needs to be lapped, jaw the base of the nozzle into a chuck and rotate the body anti clockwise to remove the nozzle.

4.2 *Inspection*

- a. Check the spring for corrosion.
- b. Check all guiding surfaces.
- c. Check swivels: spindle/disc holder, disc holder/disc.
- d. Check the seats: disc (7) and nozzle (4).

4.3 *Repair*

- a. Lap the seats of the nozzle (4) and of the disc (7). See figures 15A and 15B.
- b. NEVER lap the disc (7) against the nozzle (4).
- c. In case of damage, the disc (7) and nozzle (4) can be re-machined according to appendix C.

4.4 *Assembly*

- a. Use a new set of gaskets (23).
- b. All components must be clean and dry.
- c. Except for Oxygen service, all threads and spring load seating surfaces shall be lubricated using appropriate lubricant to avoid seizure. The guiding surfaces must be kept absolutely dry.
- d. Assemble the nozzle (4) into the body (1) and tighten with an appropriate chuck.
- e. Screw the nozzle ring (5) onto the nozzle (4) until its upper edge is below the nozzle seat level.
- f. Assemble the disc (7) and its ring (8), the disc holder (9-13) and the spindle (15), and the bellows when applicable.
- g. Assemble the body to bonnet gasket (23)
- h. Assemble the moving trim into the body.
- i. Assemble the spring and its washers (26-27).
- j. Assemble the bonnet (2).
- k. Hold the top of the spindle to prevent rotation whilst screwing in the adjusting screw (19) until the dimension recorded in paragraph 4.1.b is reached.

4.5 *Setting and test*

- a. Put the valve on an appropriate test stand.  
The test medium shall be either clean oil free compressed air for type 8100; de-mineralized water with corrosion inhibitor for type 8200.
- b. Raise the nozzle ring (5) until it gets into contact with the disc holder (9) and turn it down by 3 notches. Lock the nozzle ring (5) in rotation with the nozzle ring screw (6), taking care that the nozzle ring screw edge inserts into a notch of the nozzle screw (5), i.e. between two teeth.
- c. Increase the pressure underneath the disc and check the opening pressure.  
The pressure measurement accuracy must be 1% or better.
- d. To properly adjust the valve, use the adjusting screw (19). Before turning the adjusting screw (19), drop the pressure below 50% of the specified set pressure and prevent the spindle from rotating with a wrench.
- e. When the specified set pressure has been reached, pop the valve three to four times to check its regularity.
- f. Tighten the adjusting screw nut (20), fit the cap (3) and its gasket (23).
- g. Check the tightness at 90% of the set pressure using a recognized standard, such as API 527.
- h. Unscrew the nozzle ring screw (6), raise the nozzle ring (5) (anti clockwise) until it gets into contact with the disc holder, then lower it (clockwise) in order to reach the adjustment as per table 3.
- i. Seal the valve, identify the valve with a plate showing the authority conducting the adjustments.

**5. In service supervision of safety valves**

As safety accessories, the safety valves shall be carefully supervised and this supervision needs to be documented.

SAPAG recommend that procedures as described (but not limited to) below be applied by the user in order to preserve the safety of the equipment, reduce the maintenance costs and be conform to the regulatory rules.

- 5.1. Data file: the user should maintain a data file showing the data relevant to each safety valve: identification, technical characteristics, flow rate, operation manual.
- 5.2. Maintain a Log book of all operations performed on a particular safety valve: inspection, periodic check, test reports.
- 5.3. Maintain statistics about consumption of spare parts.

**Note on periodicity of outage:**

this periodicity is a function of numerous factors related to the operation: nature of the fluid, environment, pressure level as compared to the set pressure, temperature, installation set up, number of openings etc. so that it is impossible to specify a priori an optimum periodicity. The user shall have to establish this periodicity based on his own experience and his level of requirements.

**Table 2: trouble shooting**

<b>Trouble</b>	<b>Cause</b>	<b>Solution</b>
Leakage	Foreign matters on seats Seats damaged	Pull the lift lever Repair the valve
Chattering	Flow not sufficient Excessive back pressure	Check inlet pressure drop Check outlet pressure drop
The valve does not open	The gag is still in place	Remove the gag
The valve opens too often	The set pressure is too close to the operating pressure	Increase the set pressure
The valve opens too often	The temperature is higher than expected	Increase the set pressure or change spring material

**Table 3: positions of the nozzle ring**

<b>Orifice size</b>	<b>Set pressure ≤ 7 bar</b>	<b>Set pressure &gt; 7 bar</b>
D-E	3	6
F-G	4	7
H-J	5	10
K	6	15
L	6	19
M-N	7	21
P	8	25
Q	8	22
R	30	38
T	32	40
V-W	35	45

# Safety valves type 8100/8200

Storage, Use, Operation and Maintenance Instructions - Appendix A

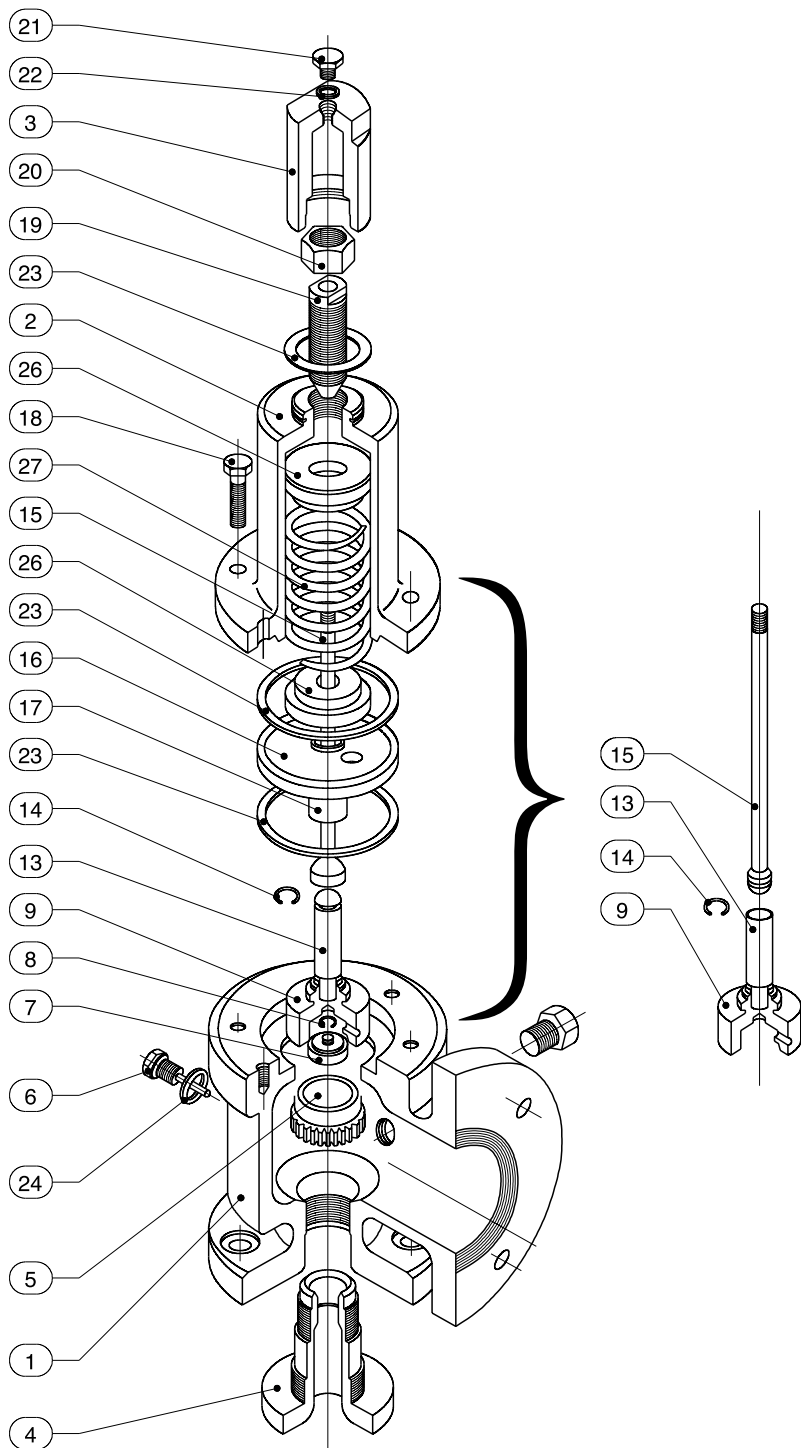

## Parts list

Ref	Designation
1	Body
2	Bonnet
3	Cap
4	Nozzle
5	Nozzle ring
6	Nozzle ring set screw
7	Disc
8	Elastic ring
9	Disc holder
10	Bellows
13	Spindle head
14	Elastic ring
15	Spindle
16	Guide plate
17	Guide
18	Bonnet bolt
19	Adjusting screw
20	Adjusting screw lock nut
21	Cap plug
22	Cap plug gasket
23	Gasket
24	Set screw gasket
25	Bellows gasket
26	Spring washer
27	Spring
29	Lever
30	Axle
31	Fork
32	Lift nut
33	Jam nut
34	Ring
35	Elastic ring
36	Pin
37	Bushing
38	Bushing gasket
39	O-ring
42	Nameplate

### Parts list

Ref	Designation
-----	-------------

1	Body
2	Bonnet
3	Cap
4	Nozzle
5	Nozzle ring
6	Nozzle ring set screw
7	Disc
8	Elastic ring
9	Disc holder
10	Bellows
13	Spindle head
14	Elastic ring
15	Spindle
16	Guide plate
17	Guide
18	Bonnet bolt
19	Adjusting screw
20	Adjusting screw lock nut
21	Cap plug
22	Cap plug gasket
23	Gasket
24	Set screw gasket
25	Bellows gasket
26	Spring washer
27	Spring
29	Lever
30	Axle
31	Fork
32	Lift nut
33	Jam nut
34	Ring
35	Elastic ring
36	Pin
37	Bushing
38	Bushing gasket
39	O-ring
42	Nameplate

**Screwed cap & plain lever type C**

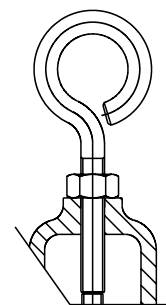
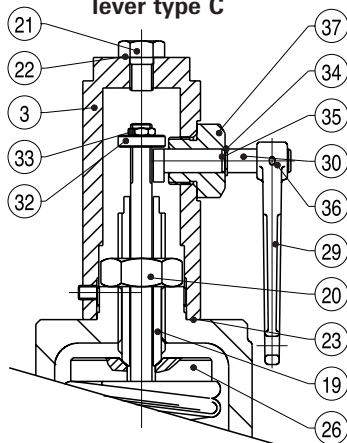

**Gag**

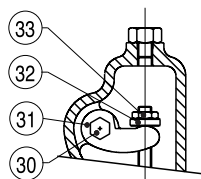

**Orifice  $\geq$  K**

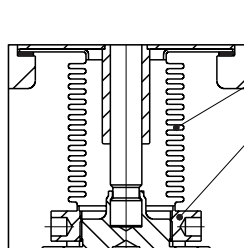

**Bellows**

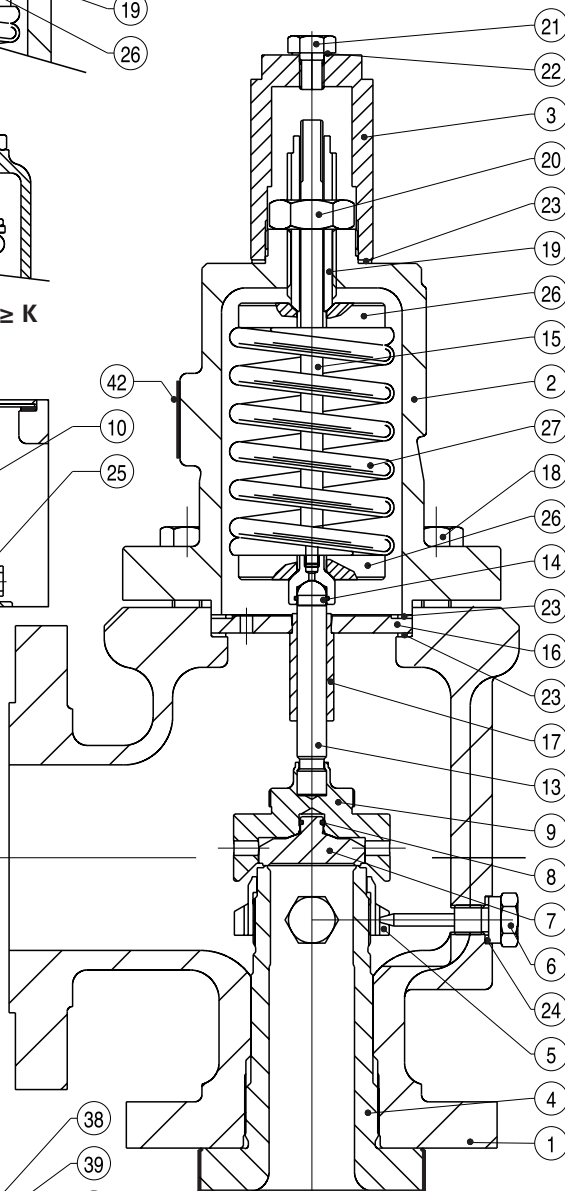

**Screwed cap type A**

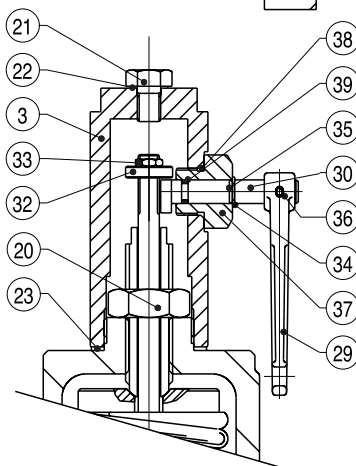

**Screwed cap & packed lever type F  
Orifice  $<$  K**

# Safety valves type 8100/8200

## Storage, Use, Operation and Maintenance Instructions - Appendix C

### Dimensions

Orifice	D (min) mm	E mm	F mm	H mm	J mm
D	10,3	0,5	14,5	13,1	see table
E	11,9	0,65	20	17,4	see table
F	7,9	0,9	24,25	21,1	see table
G	7,9	0,9	27,8	24,2	see table
H	6,4	0,9	31,1	28,5	30,3
J	9,5	0,9	39,27	36,4	38
K	11,1	1,6	46,7	43,4	45,5
L	11,1	1,6	57,4	54,1	56,2
M	11,1	1,6	64,2	60,8	63
N	12,7	1,6	70,6	66,7	69
P	15,9	2,4	84,7	80,8	83,2
Q	22,2	2,4	110,18	106,2	109
R	25,4	2,4	129,9	125,9	128,5
T	19,1	2,4	158,4	153,3	156,5

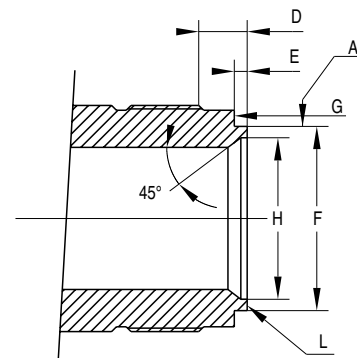

Figure 15

### Dimensions J (mm)

Orifice	D	E	F	G
Pressures				
0 to 20 bar	14	19,45	23,15	26,65
20 to 40 bar	14	19,45	23,15	26,65
40 to 60 bar	14,5	19,45	23,15	26,65
60 to 80 bar	14,5	20	24,25	26,65
100 bar and above	14,5	20	24,25	27,8

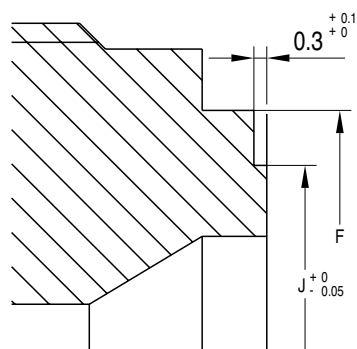

Figure 15A (continued) < 30bar

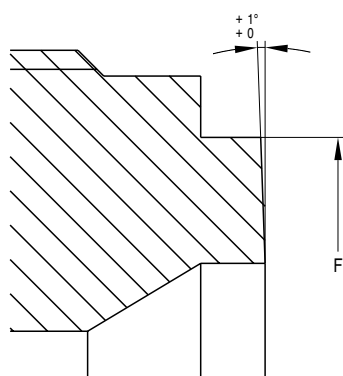

Figure 15B (continued) > 30bar

### Re-machining of the disc and nozzle seats

The seat of the disc can be re-machined as follows:

- Use a 4-chuck and position the disc with copper sheets.
- Machine surface L until defect is removed.
- Machine as fine as possible.
- The disc is ready for a new lapping.
- When the minimum value of N is reached, scrap the disc.

### Dimensions

Orifice	N size (mm)
D,E	0,15
F,G,H,J	0,25
K to T	0,4

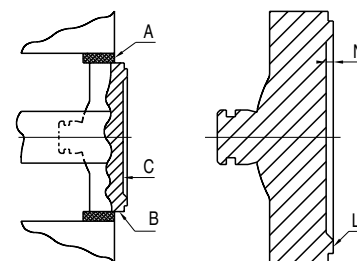

Figure 16