

---

# Furnnox Burner

Version 1

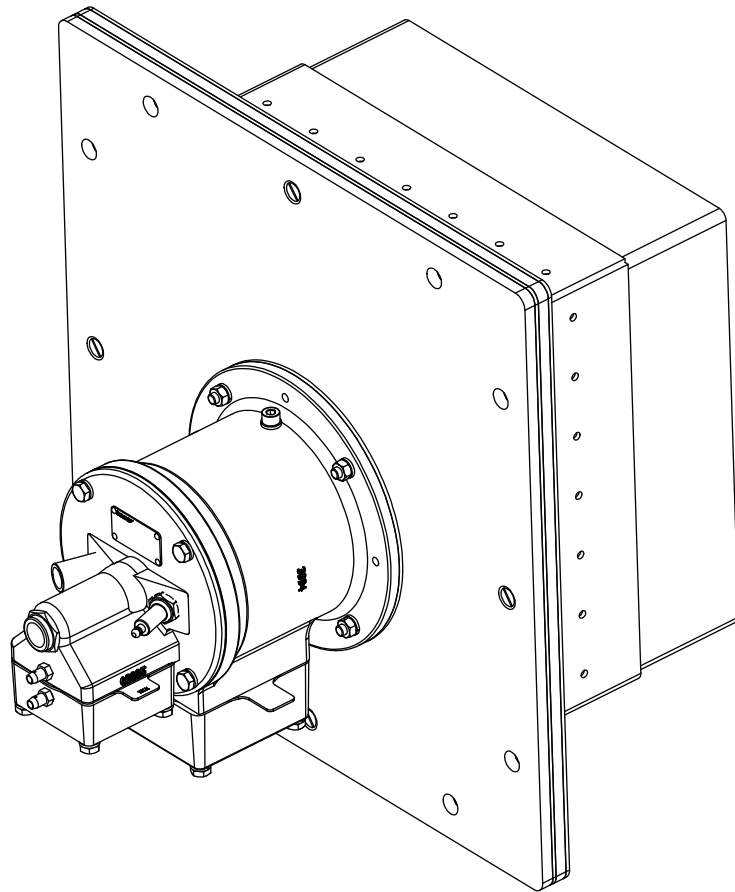

## **Copyright**

Copyright 2007 by Eclipse, inc. All rights reserved worldwide. This publication is protected by federal regulation and shall not be copied, distributed, transmitted, transcribed or translated into any human or computer language, in any form or by any means, to any third parties, without the express written consent of Eclipse, inc.

## **Disclaimer Notice**

In accordance with the manufacturer's policy of continual product improvement, the product presented in this brochure is subject to change without notice or obligation.

The material in this manual is believed adequate for the intended use of the product. If the product is used for purposes other than those specified herein, confirmation of validity and suitability must be obtained. Eclipse warrants that the product itself does not infringe upon any United States patents. No further warranty is expressed or implied.

## **Liability & Warranty**

We have made every effort to make this manual as accurate and complete as possible. Should you find errors or omissions, please bring them to our attention so that we may correct them. In this way we hope to improve our product documentation for the benefit of our customers. Please send your corrections and comments to our Marketing Communications Manager.

It must be understood that Eclipse's liability for its product, whether due to breach of warranty, negligence, strict liability, or otherwise is limited to the furnishing of replacement parts and Eclipse will not be liable for any

other injury, loss, damage or expenses, whether direct or consequential, including but not limited to loss of use, income, or damage to material arising in connection with the sale, installation, use of, inability to use, or the repair or replacement of Eclipse's products.

Any operation expressly prohibited in this manual, any adjustment, or assembly procedures not recommended or authorized in these instructions shall void the warranty.

## **Document Conventions**

There are several special symbols in this document. You must know their meaning and importance.

The explanation of these symbols follows below. Please read it thoroughly.

## **How To Get Help**

If you need help, contact your local Eclipse representative. You can also contact Eclipse at:

1665 Elmwood Rd.  
Rockford, Illinois 61103 U.S.A.  
Phone: 815-877-3031  
Fax: 815-877-3336  
<http://www.eclipsenet.com>

Please have the information on the product label available when contacting the factory so we may better serve you.

 <b>ECLIPSE</b> <small>Innovative Thermal Solutions</small>	<a href="http://www.eclipsenet.com">www.eclipsenet.com</a>
Product Name	
Item #	
S/N	
DD MMM YYYY	



This is the safety alert symbol. It is used to alert you to potential personal injury hazards. Obey all safety messages that follow this symbol to avoid possible injury or death.



Indicates a hazardous situation which, if not avoided, will result in death or serious injury.



Indicates a hazardous situation which, if not avoided, could result in death or serious injury.



Indicates a hazardous situation which, if not avoided, could result in minor or moderate injury.

**NOTICE**

Is used to address practices not related to personal injury.

**NOTE**

Indicates an important part of text. Read thoroughly.

---



# Table of Contents

<b>1 Introduction</b> .....	<b>4</b>
Product Description.....	4
Audience.....	4
Purpose.....	4
Related Documents.....	4
<b>2 Safety</b> .....	<b>5</b>
Safety Warnings.....	5
Capabilities.....	5
Operator Training.....	5
Replacement Parts.....	5
<b>3 Installation</b> .....	<b>6</b>
Introduction.....	6
Handling & Storage.....	6
Checklist Before Installation.....	7
Position of Components.....	6
Approval of Components.....	6
Electrical Supply.....	7
Prepare the Burner.....	7
Combustion Block Installation.....	8
Checklist After Installation.....	10
Refractory Block Curing Schedule.....	10
<b>4 Adjustment, Start &amp; Stop</b> .....	<b>11</b>
Modulating Gas & Air Ratio System.....	11
Set the Bypass Pilot Gas (Optional).....	13
Start Procedure.....	14
Stop Procedure.....	14
<b>5 Maintenance &amp; Troubleshooting</b> .....	<b>15</b>
Introduction.....	15
Maintenance.....	15
Monthly Checklist.....	15
Yearly Checklist.....	15
Troubleshooting Guide.....	16
<b>Appendix</b> .....	<b>i</b>
Conversion Factors.....	i

# Introduction

# 1

## Product Description

The Furnnox is a Low NO<sub>x</sub> nozzle-mix burner using ambient or preheated combustion air with temperatures up to 1100°F (600°C). The Furnnox burner is designed for application on direct fired high temperature range, 1400°F to 2800°F (760°C to 1540°C), furnaces.

By staging the combustion air the burner NO<sub>x</sub> emissions are reduced compared to standard nozzle mixing burners. Staging of the combustion air is achieved by secondary air holes in the burner refractory block.

The Furnnox burner is designed for direct ignition and flame supervision by UV scanner.

## Audience

This manual has been written for personnel already familiar with all aspects of a gas burner and its add-on components, also referred to as the burner package.

These aspects are:

- Installation
- Use
- Maintenance
- Safety

The audience is expected to be qualified and have experience with this type of equipment and its working environment.

## Purpose

The purpose of this manual is to make sure that you carry out the installation of a safe, effective and trouble-free system.

## Furnnox Documents

### **Installation Guide No. 210**

- This document

### **Datasheet Series No. 210**

- Available for individual Furnnox models
- Required to complete installation

### **Spare Parts List Series No. 210**

- Recommended replacement part information

## Related Documents

- EFE 825 (Combustion Engineering Guide)
- Eclipse Bulletins and Information Guides: 210, 610, 710, 720, 730, 742, 744, 760, 930, I-354

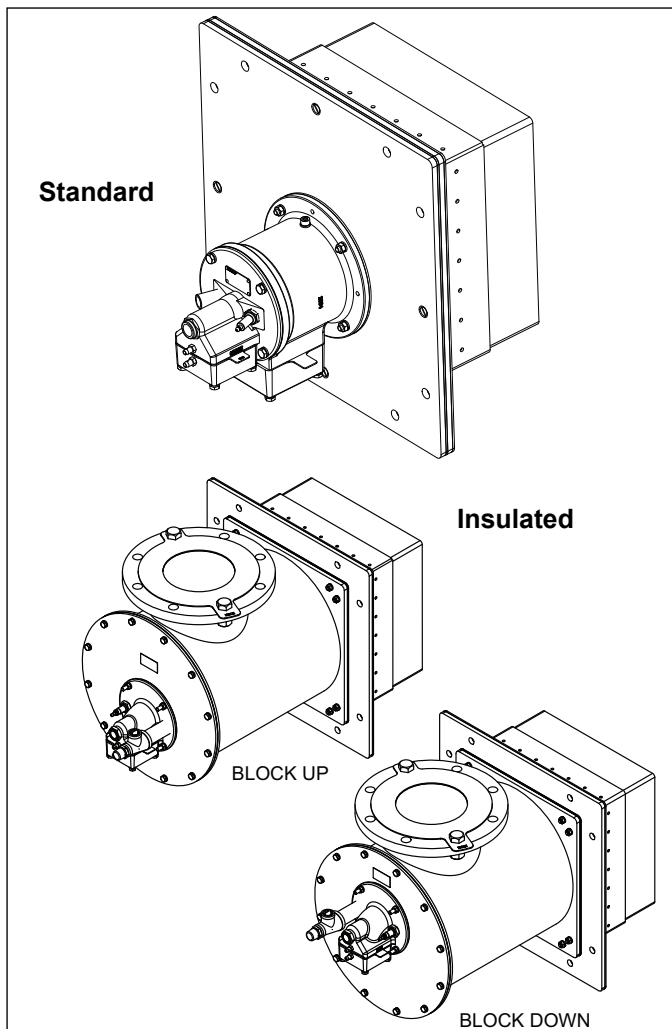

**Figure 1.1. Standard & Insulated Furnnox Burner**

# Safety

Important notices which help provide safe burner operation will be found in this section. To avoid personal injury and damage to the property or facility, the following warnings must be observed. All involved personnel should read this entire manual carefully before attempting to start or operate this system. If any part of the information in this manual is not understood, contact Eclipse before continuing.

## Safety Warnings



### **DANGER**

- **The burners, described herein, are designed to mix fuel with air and burn the resulting mixture. All fuel burning devices are capable of producing fires and explosions if improperly applied, installed, adjusted, controlled or maintained.**
- **Do not bypass any safety feature; fire or explosion could result.**
- **Never try to light a burner if it shows signs of damage or malfunction.**



### **WARNING**

- **The burner and duct sections are likely to have HOT surfaces. Always wear the appropriate protective equipment when approaching the burner.**
- **Eclipse products are designed to minimize the use of materials that contain crystalline silica. Examples of these chemicals are: respirable crystalline silica from bricks, cement or other masonry products and respirable refractory ceramic fibers from insulating blankets, boards, or gaskets. Despite these efforts, dust created by sanding, sawing, grinding, cutting and other construction activities could release crystalline silica. Crystalline silica is known to cause cancer, and health risks from the exposure to these chemicals vary depending on the frequency and length of exposure to these chemicals. To reduce the risk, limit exposure to these chemicals, work in a well-ventilated area and wear approved personal protective safety equipment for these chemicals.**

### **NOTICE**

- **This manual provides information regarding the use of these burners for their specific design purpose. Do not deviate from any instructions or application limits described herein without written approval from Eclipse.**

## Capabilities

Only qualified personnel, with sufficient mechanical aptitude and experience with combustion equipment, should adjust, maintain or troubleshoot any mechanical or electrical part of this system.

## Operator Training

The best safety precaution is an alert and trained operator. Train new operators thoroughly and have them demonstrate an adequate understanding of the equipment and its operation. A regular retraining schedule should be administered to ensure operators maintain a high degree of proficiency.

## Replacement Parts

Order replacement parts from Eclipse only. All Eclipse approved valves or switches should carry UL, FM, CSA, CGA and/or CE approval where applicable.

# Installation

## Introduction

In this section you will find the information and instructions needed to install the burner and system components.



### **WARNING**

- **Only qualified competent personnel with experience of combustion systems are allowed to install, adjust or maintain the burner.**
- **All installation work must be carried out in compliance with current legislated standards.**

## Handling & Storage

### **Handling**

- Make sure the area is clean.
- Inspect the burner, ensure that all components are clean and free from damage.
- Use appropriate support and handling equipment when lifting the burner.
- Protect the burner from weather, damage, dirt and moisture.
- Protect the burner and components from excessive temperatures and humidity.

### **Storage**

- Make sure the components are clean and free of damage.
- Store the components in a cool, clean, dry room.
- After making sure everything is present and in good condition, keep the components in original packages as long as possible.

## Position of Components

The position and amount of components are determined by the kind of control method chosen. Furnnox burners are applied on furnaces using multiple burners and multiple control zones, for which electronic gas air ratio control systems are used.

Due to the variety of these control systems this manual does not describe the design.

## Approval of Components

### **Limit Controls & Safety Equipment**

All limit controls and safety equipment must comply with all applicable local codes and/or standards and must be listed for combustion safety by an independent testing agency. Typical application examples include:

- American: NFPA 86 with listing marks from UL, FM, CSA
- European: EN 746-2 with CE mark from TuV, Gastec, Advantica

### **Electrical Wiring**

All the electrical wiring must comply with all applicable local codes and/or standards such as:

- NFPA Standard 70
- IEC60364
- CSA C22
- BS7671

### **Gas Piping**

All the gas piping must comply with all applicable local codes and/or standards such as:

- NFPA Standard 54
- ANSI Z223
- EN 746-2

### **Where to Get the Standards:**

#### **The NFPA Standards are available from:**

National Fire Protection Agency  
Batterymarch Park  
Quincy, MA 02269  
[www.nfpa.org](http://www.nfpa.org)

#### **The ANSI Standards are available from:**

American National Standard Institute  
1430 Broadway  
New York, NY 10018  
[www.ansi.org](http://www.ansi.org)

#### **The UL Standards are available from:**

333 Pfingsten Road  
Northbrook, IL 60062  
[www.ul.com](http://www.ul.com)

### The FM Standards are available from:

1151 Boston-Providence Turnpike  
PO Box 9102  
Norwood, MA 02062  
www.fmglobal.com/approvals

### Information on the EN standards and where to get them is available from:

Comité Européen de Normalisation  
Stassartstraat 36  
B-1050 Brussels  
Phone: +32-25196811  
Fax: +32-25196819  
www.cen.eu

Comité Européen de Normalisation Electronique  
Stassartstraat 36  
B-1050 Brussels  
Phone: +32-25196871  
Fax: +32-25196919  
www.cenelec.org

## Checklist Before Installation

### Air Supply

To admit fresh combustion air from outdoors, provide sufficient opening in the room to allow fresh air to enter according to local regulations.

If there are corrosive fumes or materials in the air, then supply the burner with clean air from an uncontaminated area.

### Exhaust

Do not allow exhaust fumes to accumulate in the work area. Provide some positive means for exhausting from the furnace and the building.

### Access

Make sure that you install the burner in such a way that you can gain easy access for inspection and maintenance.

### Environment

Make sure the local environment matches the original operating specifications. Check the following items:

- Voltage, frequency and stability of the electrical power
- Fuel type and supply pressure of the fuel
- Availability of enough fresh, clean combustion air
- Humidity, altitude and temperature of air
- Presence of damaging corrosive gases in the air
- Prevent direct exposure to water

## Electrical Supply

The burner should be controlled via a sequence programmer, approved according to the local standards. For connections, please refer to the related wiring diagrams.



## **WARNING**

- **Wiring to the burner must be in accordance with current wiring standards. It is vital that the live and neutral wires are connected correctly as reversal could present a hazard. Also the grounding must be checked to ensure a good connection.**
- **Gas pipe work must NOT be used for grounding purposes.**
- **If burner control signals are supplied via a flame safeguard control panel provided by others, Eclipse can not accept any responsibility for incorrect interfacing.**

## Prepare the Burner

Several components must be installed on a burner before it can operate. Installation instructions follow.

It is possible to change the relative position of the gas inlet with respect to the air inlet. This can be convenient for the routing of the piping.

### Rotate the Rear Cover (On Standard Body Only, Optional)

To rotate the rear cover, do the following (see Figure 3.1):

1. Disconnect the piping at a union in the piping or the inlet flanges ❶ provided on the burner.

**NOTE:** Be careful not to lose or damage the orifice plate or the o-rings.

2. Remove the four bolts ❷.
3. Remove the rear cover ❸ from the burner housing ❹.
4. Rotate the rear cover ❸ to the position that you want.
5. Put the rear cover ❸ in position against the burner housing ❹.
6. Install the four bolts ❷.
7. Reconnect the piping. Make sure that the o-rings show no signs of damage.



**! DANGER**

- If you connect the flame sensor of a burner to the electrical circuit of the wrong burner, then you can cause fires and explosions.

There are two different types of flame sensors; UV scanner and flamerod.

**NOTICE**

- Adjustments may vary from Eclipse published values if the flame controls other than those recommended in the Design Guide are used. Consult with the engineer who specified the alternate control for limitations.

**UV Scanner**

For detailed information on how to install and connect a UV scanner, refer to scanner information guide.

**Installing the Spark Plug**

Install the spark plug into the opening in the rear cover.

**NOTE:** Do *not* apply any grease to the threads of the spark plug. You can cause bad grounding of the spark plug if you apply grease to it. Bad grounding of the spark plug results in a weak spark.

**Combustion Block Installation**

**For Hard Refractory Lined Furnaces:**  
(See Figure 3.3)

- Allow approximately 1/2" (12mm) clearance all around the refractory combustor.
- Be sure the gasket ① is installed between the burner ② and the refractory combustor flange ③.
- Install the gasket ④ between the refractory combustor flange ③ and the furnace shell ⑤.
- Support the weight of the refractory combustor ⑥ with hard brickwork anchored to the furnace shell ⑦. Fill the 1/2" space between the refractory combustor ⑥ and the three unsupported sides with soft gasket material ⑧.

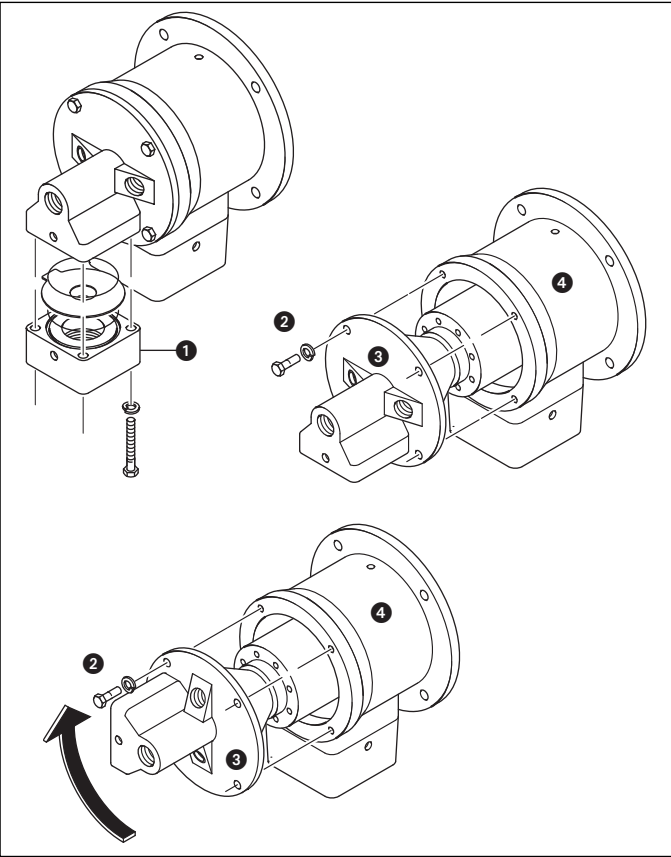

**Figure 3.1. Rotate the Rear Cover**

**Installing the Flame Sensor**

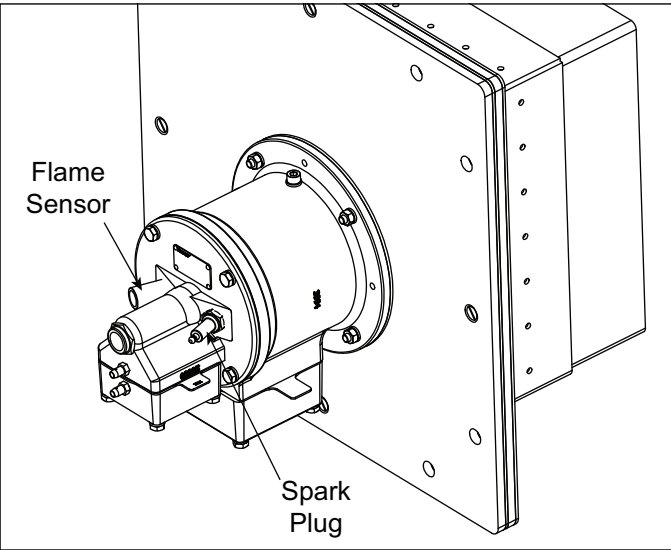

**Figure 3.2. Installing the Flame Sensor**

1. Install the flame sensor into the 1/2" NPT opening in the rear cover.
2. Make sure that you connect the flame sensor of a burner to the electrical circuit of that burner.



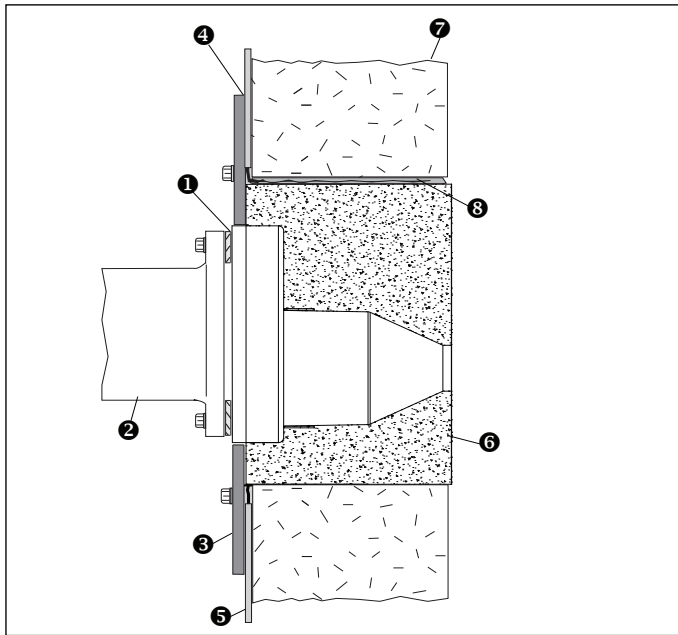

Figure 3.3 Hard Refractory Lined Furnaces

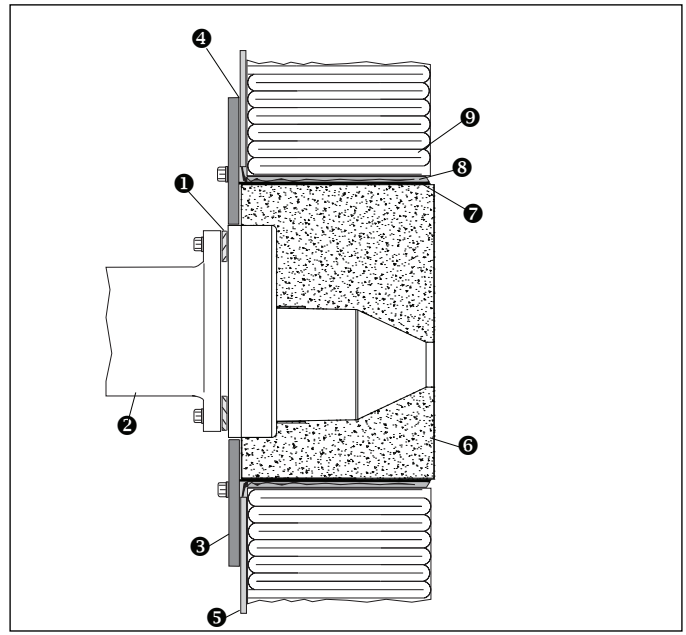

Figure 3.4 Fiber Lined Furnaces

## NOTICE

- After initial firing of furnace at design temperature, check fiber shrinkage in vicinity of burner tile. Fill any voids with bulk fiber insulation to maintain a gas tight seal between furnace interior and shell.

### For Fiber Lined Furnaces: (See Figure 3.4 and Figure 3.5)

- Be sure the gasket 1 is installed between the burner 2 and the refractory combustor flange 3.
- Install the gasket 4 between the refractory combustor flange 3 and the furnace shell 5.
- Coat the outside of the refractory combustor 6 with an air setting refractory cement 7. Also, fill clearance gap between the furnace shell 5 opening and the refractory combustor 6 with cement.
- Wrap the exposed refractory combustor 6 length with two layers of continuous strip of blanket insulation 8.
- Compress and secure the blanket insulation 8 to the refractory combustor 6 using a suitable, non-metallic tape. Compression of the blanket insulation 8 should be at least 25%.
- Install the fiber insulation 9 tightly against the wrapped refractory combustor 6, following the suppliers recommended procedure for anchoring and compressing the fiber 9.

- For applications exceeding 2200 °F (1200 °C) install a ceramic fiber board shield 10 suitable for the furnace design temperature as illustrated in Figure 3.5.
- Anchor the shield 10 to the refractory combustor 6 and the fiber lining 9 with a high temperature, air setting refractory cement 11 and ceramic anchoring devices 12.

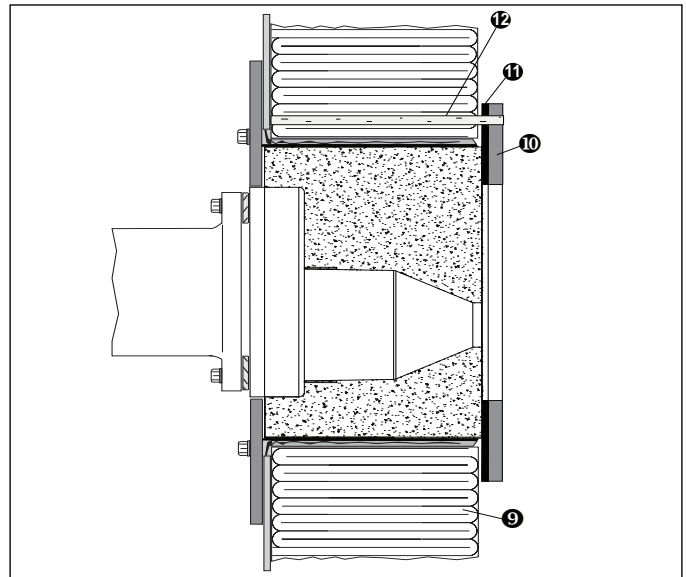

Figure 3.5

**NOTE:** For furnaces that are unable to support the weight of the refractory block, a stainless steel shelf can be welded to the shell for support.

## NOTICE

- **After initial firing of the furnace at design temperature, check for fiber shrinkage in the vicinity of the refractory combustor. Fill any voids with bulk fiber insulation to maintain a gas-tight seal between the furnace interior and shell.**

### **Piping Installation**

#### **Straight Run of Pipe Before a Metering Orifice**

**NOTE:** There must be a run of pipe with a straight length of at least 10 pipe diameters before the burner metering orifice. If you do not do this, the pressure readings will be inaccurate.

#### **Pipe Connections**

Install a pipe union in the gas line to the burner. This simplifies removal of the burner.

The use of flexible pipe nipples in the gas line to the burner is optional. Flexible nipples can absorb stress due to heat expansion and slight misalignment.

**NOTE:** The pressure drop of the gas in the piping is a critical parameter. Make sure that the size of all the piping is large enough to prevent excessive pressure losses.

### **Checklist After Installation**

To verify the system was properly installed, perform the following checks:

1. Make sure that there are no leaks in the gas lines and the air lines.
2. Make sure all the components of the flame monitoring control system are properly installed. This includes verifying that all switches are installed in correct locations and all wiring, pressure, and impulse lines are properly connected.
3. Make sure components of the spark ignition system are installed and functioning properly.
4. Make sure that the blower rotates in the correct direction. If incorrect, then have a qualified electrician rewire the blower to reverse its rotation.
5. Make sure all valves are installed in proper locations and are properly oriented relative to the gas or air flow direction.

### **Refractory Block Curing Schedule**

The refractory block was cured at the factory up to a temperature of 650°F (345°C). Final curing should be done after installation.

The recommended curing schedule is:

- Ambient to 600°F (315°C) at 100°F (55°C) per hour.
- 600°F (315°C) to 1000°F (540°C) at 25°F (14°C) per hour. Hold the refractory block at 1000°F (540°C) for 12 hours.
- Cool or raise the operating temperature at a rate of 100°F (55°C) per hour.

# Adjustment, Start & Stop

# 4

In this chapter you will find instructions on how to adjust a system, and how to start and stop a system.

## DANGER

- Do not bypass any safety feature. You can cause fires and explosions.

### Modulating Gas & Air Ratio System

If you adjust an on-ratio system for the first time, you must follow these steps:

#### Step 1: Reset the System

1. Close the automatic gas valves and gas cocks.
2. Fully open the manual air butterfly valve at each burner.
  - a. Drive the automatic zone air control valve to high fire.
  - b. Adjust the automatic zone air control valve so that it is fully open.
3. Start the blower.

## NOTICE

- Make sure that the blower rotates in the correct direction. If incorrect, have a qualified electrician rewire the blower to reverse its rotation.
4. Adjust the eductor flow valve to set the flow measured across the orifice to the flow specified by Eclipse for your application.

#### Step 2: Set High Fire Air

1. Set the system to high fire, but **DO NOT** ignite the burner(s).
2. Use the orifice flow data (provided by orifice manufacturer) to determine the pressure drop across the orifice necessary for high fire air flow.

**NOTE:** If using single diaphragm ratio regulator control, set air flow to 35% excess air to account for temperature changes in combustion air.

3. Set high fire air using the manual combustion air butterfly to achieve the pressure differential determined in Step 2.

**NOTE:** A pressure tap is open when the screw inside the tap is unscrewed approximately half a turn.

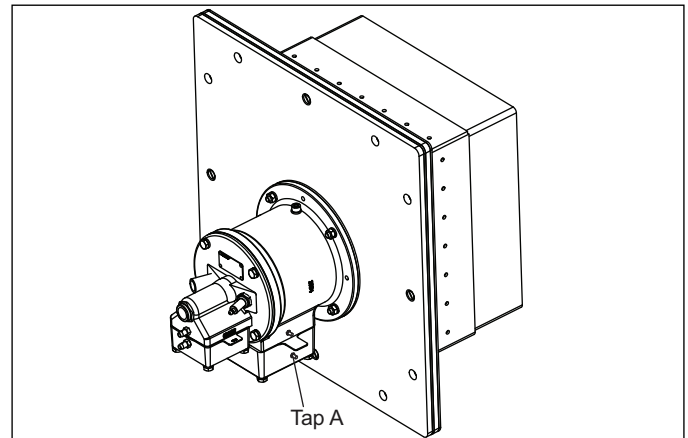

Figure 4.1. Set High Fire Air

**NOTE:** Insulated Body Furnnox Burners do not have a Tap(s) A. For insulated housing version, use pressure taps in supply lines to the burner(s).

#### Burner system:

- a. **Standard Version**, open all pressure tap(s) A.

**Insulated Housing Version**, use pressure taps in the supply lines to the burner.

- b. Measure and note the static pressure at Tap A for all the burners.
  - c. If all the measured static pressures are within 0.3" w.c. (0.75 mbar) of each other, then proceed to the next section. If the variation is greater than 0.3" w.c. (0.75 mbar) it will be necessary to adjust the manual air butterfly valve at each burner to improve the balance.
  - d. Make sure that all the pressure taps are closed.
4. Repeat **the preceding** for other zones (if any).

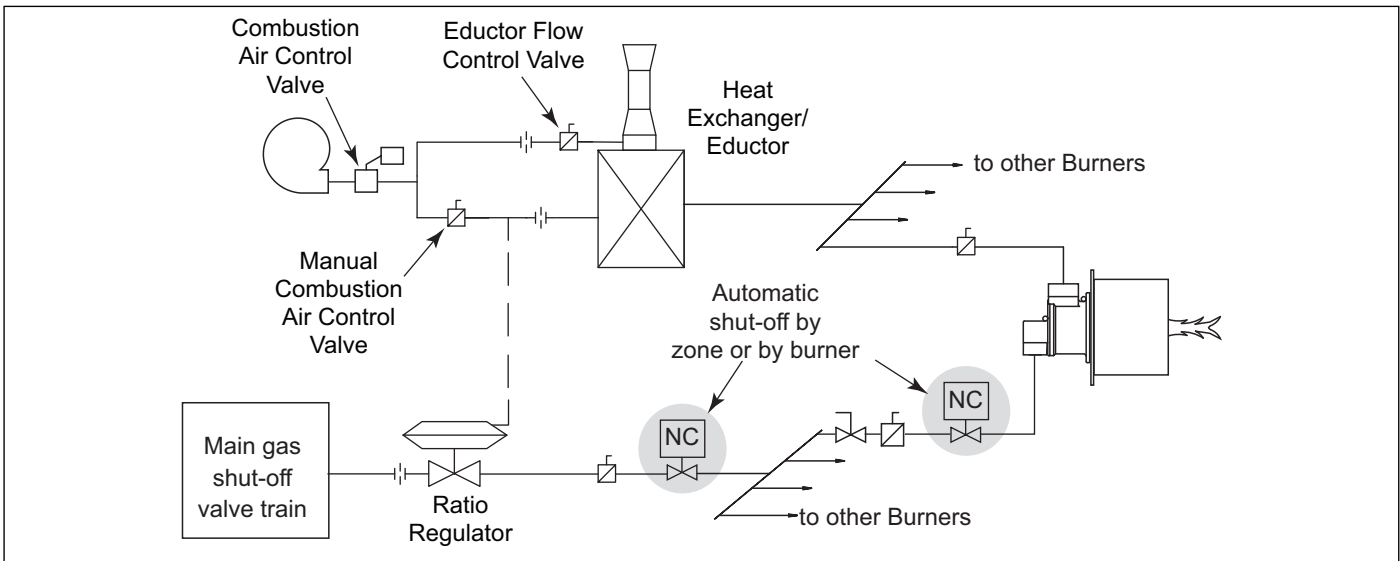

**Figure 4.2. Burner System**

### Step 3: Set Low Fire Air

1. Set the system to low fire.
2. Connect the manometer to tap A (air inlet pressure tap).
3. Adjust the automatic zone air control valve until the low fire static air pressure is 0.2" w.c. This is the initial setting only. Further adjustment may be required.
4. Repeat 2 and 3 for the other zones (if any).

### Step 4: Verify the Air Settings

Make sure all the settings are still the same after you cycle the system several times between high and low fire.

### Step 5: Ignite the Burners



- **This procedure assumes that a flame monitoring control system is installed and is serviceable. It also assumes that normal low fire start is being used. If low fire gas is too low to be used for ignition, refer to options in “Set the Bypass Pilot Gas (Optional)” on page 13.**

1. Drive the zone air automatic control valve to low fire.
2. Make sure the combustion air blower is running.
3. Set the manual gas butterfly valve at each burner to 50% open.

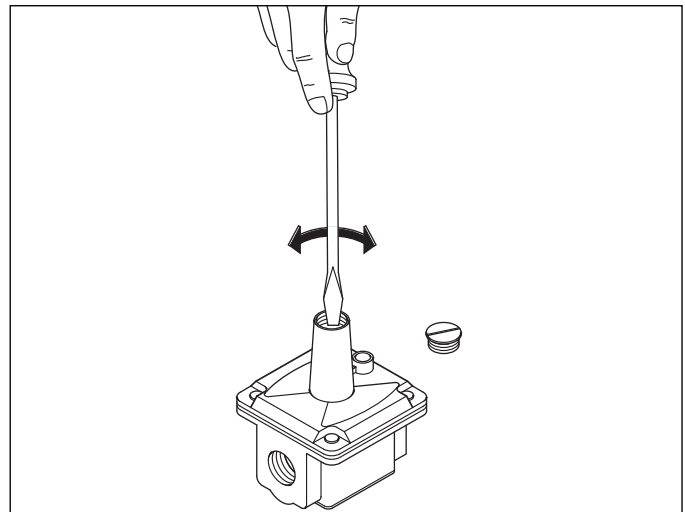
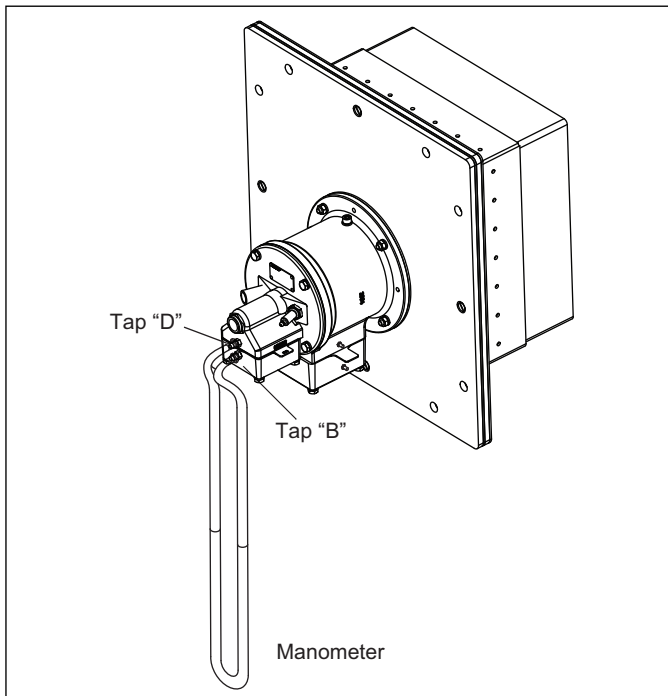

**Figure 4.3. Adjusting Ratio Regulator Screw**

4. Adjust the ratio regulator as required for low fire.
5. Open manual gas cock at each burner.
6. Initiate the ignition sequence through the flame monitoring control system.
7. Check that all the burners in the zone have ignited. If all the burners have ignited, drive the combustion air butterfly valve to high fire. Verify flame is present at each burner. If burners do not light, increase the gas flow by adjusting the ratio regulator, repeat step 6.
8. Recheck the high fire air settings.

**NOTE:** As application temperature increases, pressure will change. Depending on control method, readjustment of the manual combustion air butterfly valve may be necessary.

## Step 6: Set High Fire Gas



**Figure 4.4. Set High Fire Gas**

1. Use the gas curve from the appropriate Furnnox datasheet for the gas being used to find the differential gas pressure needed at high fire. This is the target value for high fire.
2. Connect the manometer to taps B and D (across the gas orifice).
3. Measure the high fire differential gas pressure for the first burner.
4. Adjust the gas butterfly valve at the burner until the gas flow is at the target value.
5. Repeat 3 thru 4 for the other burners in the zone.
6. Check the gas pressure at the inlet to the zone ratio regulator. This should be at least 5" w.c. (12.5 mbar) higher than the loading line pressure. It should not exceed the maximum pressure rating of the ratio regulator.



### **WARNING**

- **Insufficient gas inlet pressure may cause the proportionator to remain fully open as the burner system turns down from high fire, causing excess fuel operation and possible accumulation of unburned fuel in the chamber. In extreme cases, this may cause explosions or fires.**

## Step 7: Set Low Fire Gas

1. Drive the system to low fire.
2. Use the gas curve from the appropriate Furnnox datasheet for the gas being used to determine the differential gas pressure required for low fire. This is your target value for low fire.
3. Measure the gas pressure at the first burner.
4. Adjust the ratio regulator until the gas flow is on the target value.

**NOTE:** It is very difficult to measure the very low pressures experienced at low fire, and it may be necessary to rely on visual inspection. The main intent is to provide a clean stable flame with a good flame signal that will not cause the furnace temperature to overshoot.

If the pressure required is too low to be measured, adjust the ratio regulator until a gas flow is obtained that will provide a clean stable flame with a strong flame signal.

## Step 8: Verify the Gas Settings

Make sure that all settings are still the same after cycling the system several times between high and low fire.

## Step 9: Readjust Settings

As application temperature increases, setting may vary. Recheck and readjust as temperatures increase.

**NOTE:** When all the settings have been completed, mark the position of the indicator on the butterfly valves to indicate valve position.

### **Set the Bypass Pilot Gas (Optional)**

1. Set the system to low fire.
2. Make sure that the blower is on.



### **WARNING**

- **Before you perform this procedure, make sure the flame monitoring control system is working.**
3. Use the flame monitoring control system to start the ignition and the bypass pilot gas for all the burners in the zone.
  4. Adjust the manual butterfly valve in the bypass line until you obtain reliable ignition within the required trial for ignition time limit.
  5. Repeat 4 for all the other burners and zones (if any).

## **Start Procedure**

1. Start the blower.
2. Open all the gas cocks.
3. Start the ignition sequence.
4. Verify that flame is present at each burner.



**DANGER**

- **If a burner does not light, and the system does not shut down automatically, then you must close the main gas cock. An uncontrolled flow of gas can cause fires and explosions.**
- **Do not touch the ignition plug or the ignition wire when the ignition is on. You will get a shock.**

## **Stop Procedure**

1. Close the following valves:
  - The manual gas cock for each burner or zone
  - The manual gas cock at the main control valve
  - All the manual shut-off valves in the gas line upstream of the burner gas cock
2. Let the burners cool down. Keep the blower on until the chamber temperature is less than 1000°F (500°C) and then stop the blower.

***NOTICE***

- **Keeping the blower on after the burner is off protects the burner and the other components from hot gases that flow back through the burner.**

# Maintenance & Troubleshooting

# 5

## **Introduction**

This section is divided into two parts:

- The first part describes the maintenance procedures.
- The second part helps identify problems that may occur and gives advice on how to solve these problems.

## **Maintenance**

Preventive maintenance is the key to a reliable, safe and efficient system. The core of any preventive maintenance program is a list of periodic tasks.

The following are suggestions for a monthly list and a yearly list.

**NOTE:** The monthly list and the yearly list are an average interval. If your environment is dirty, then the intervals may be shorter. Other standards may take precedence for your particular application.

## **Monthly Checklist**

- Test (leak test) safety shut-off valves for tightness of closure.
- Test air pressure switch settings by checking switch movements against pressure settings and comparing with actual impulse pressure.
- Visually check ignition cable and connectors.
- Inspect impulse piping for leaks.
- Make sure that the following components are not damaged or distorted:
  - the spark plugs
  - the flame sensors
  - if applicable, remove and clean all the orifice plates

## **Yearly Checklist**

Perform all monthly checklists plus:

- Inspect flame-sensing devices for good condition and cleanliness.
- Check for proper inlet air/gas ratios.
- Test all the alarm systems for proper signals.
- Check ignition spark plugs and check proper gap.
- Check valve motors and control valves for free, smooth action, and adjustment.
- Check for proper operation of the ventilating equipment.
- Test the interlock sequence of all safety equipment; manually make each interlock fail, noting that related equipment closes or stops as specified by the manufacturer.
- Test flame monitoring control system by manually shutting off gas to the burner.
- Test main fuel hand-valves for operation.
- Clean or replace the combustion air blower filter.
- Remove, clean and inspect all the burners.
- Make sure that the following components are not damaged or distorted:
  - the burner nozzle
  - the flame tube or combustion block



## Troubleshooting Guide

Problem	Possible Cause	Solution
Cannot initiate start sequence	Main power is off	Make sure power is on to control system.
	No power to control	Call qualified electrician to investigate.
	Air pressure switch has not made contact	Check air-pressure switch adjustment. Check air filter. Check blower rotation. Check outlet pressure from blower.
	High gas pressure switch has tripped	Check incoming gas pressure. Adjust gas pressure if necessary. Check pressure switch setting and operation.
	Low gas pressure switch has activated	Check incoming gas pressure. Adjust gas pressure if necessary. Check pressure switch setting and operation.
	Malfunction of flame monitoring control system such as shorted out flame sensor or electrical noise in the sensor line	Have a qualified electrician investigate and rectify.
	Purge cycle not completed	Check flame monitoring control system, purge timer, interlocks and limit switches.
Start-up sequence runs but burner does not light	No ignition: • There is no power to the ignition transformer	Restore power to the ignition transformer.
	No ignition: • Open circuit between the ignition transformer and the spark plug	Repair or replace the wiring and connectors to the spark plug.
	No ignition: • The spark plug needs cleaning	Clean the spark plug.
	No ignition: • The spark plug is not correctly grounded to the burner	Clean the threads of the spark plug and the burner. Do not apply grease to the thread of the spark plug.
	Too much gas: • Improper gas valve train sequence	Verify solenoid valve is downstream of proportionator.
	Too much gas: • Manual gas butterfly valves have been opened too far	Check pressures and settings against start-up report and adjust as necessary.
	Too much gas: • Gas pressure out of the main gas pressure regulator is too high	Check start-up setting. If necessary, remove regulator and investigate.
	Not enough gas: • The gas pressure out of the main gas pressure regulator is too low	Check start-up settings. Check regulator and adjust if necessary.

<b>Problem</b>	<b>Possible Cause</b>	<b>Solution</b>
Start-up sequence runs but burner does not light	Not enough gas: • Start gas solenoid valve does not open	Check solenoid valve coil for proper operation. Replace if necessary.
	Not enough gas: • Gas valve not open	Check wiring to the automatic gas shut-off valve.
	Not enough gas: • Air in the gas line	Check output from the flame safeguard. Open gas cock. Purge gas line.
The low fire flame is weak or unstable	• Low fire adjusted too low	Increase low fire gas setting.
	• Not enough gas	Check start-up settings and adjust to increase low gas flow.
	• Not enough air	Check start-up settings. Investigate any change, i.e. blocked filter, loose connections
The burner goes off when it cycles to high fire	• Insufficient air (flame too rich)	Check start-up settings. Check air filter, clean, or replace if required.
The burner is erratic and does not respond to adjustment	• Flame signal weak	Check condition of flame monitoring device.
	• Internal damage to the burner. Some parts inside the burner may be loose or dirty	Contact your Eclipse representative or the Eclipse factory.
The burner is unstable or produces soot or smoke	• The air/gas ratio is out of adjustment	Measure all the gas pressures and air pressures. Compare to initial start-up settings, and adjust them where necessary.
Cannot achieve full capacity	• Air filter is blocked	Clean or replace the air filter.
	• Gas pressure is too low into the main gas pressure regulator	Adjust gas pressure.
	• Increased furnace/chamber pressures	Re-check setup pressures.
	• Poor piping practices	Contact factory.



# Appendix

## Conversion Factors

### Metric to English

From	To	Multiply By
actual cubic meter/h (am <sup>3</sup> /h)	actual cubic foot/h (acfh)	35.31
normal cubic meter/h (Nm <sup>3</sup> /h)	standard cubic foot /h (scfh)	38.04
degrees Celsius (°C)	degrees Fahrenheit (°F)	(°C x 9/5) + 32
kilogram (kg)	pound (lb)	2.205
kilowatt (kW)	Btu/h	3415
meter (m)	foot (ft)	3.281
millibar (mbar)	inches water column ("w.c.)	0.402
millibar (mbar)	pounds/sq in (psi)	14.5 x 10 <sup>-3</sup>
millimeter (mm)	inch (in)	3.94 x 10 <sup>-2</sup>
MJ/Nm <sup>3</sup>	Btu/ft <sup>3</sup> (standard)	26.86

### Metric to Metric









From	To	Multiply By
kiloPascals (kPa)	millibar (mbar)	10
meter (m)	millimeter (mm)	1000
millibar (mbar)	kiloPascals (kPa)	0.1
millimeter (mm)	meter (m)	0.001

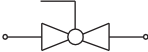

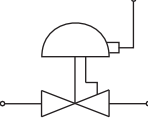
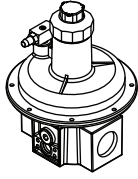

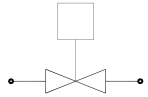
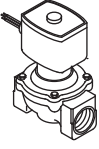



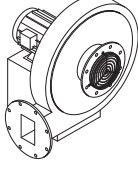

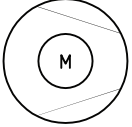
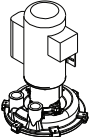
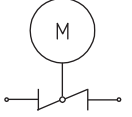
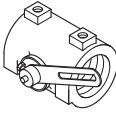
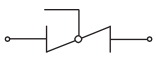
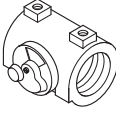
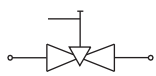

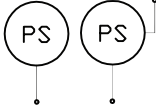
### English to Metric

From	To	Multiply By
actual cubic foot/h (acfh)	actual cubic meter/h (am <sup>3</sup> /h)	2.832 x 10 <sup>-2</sup>
standard cubic foot /h (scfh)	normal cubic meter/h (Nm <sup>3</sup> /h)	2.629 x 10 <sup>-2</sup>
degrees Fahrenheit (°F)	degrees Celsius (°C)	(°F - 32) x 5/9
pound (lb)	kilogram (kg)	0.454
Btu/h	kilowatt (kW)	0.293 x 10 <sup>-3</sup>
foot (ft)	meter (m)	0.3048
inches water column ("w.c.)	millibar (mbar)	2.489
pounds/sq in (psi)	millibar (mbar)	68.95
inch (in)	millimeter (mm)	25.4
Btu/ft <sup>3</sup> (standard)	MJ/Nm <sup>3</sup>	37.2 x 10 <sup>-3</sup>

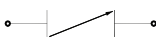

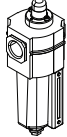
# System Schematics

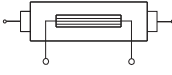
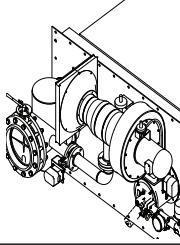
Symbol	Appearance	Name	Remarks	Bulletin/ Info Guide
		Gas Cock	Gas cocks are used to manually shut off the gas supply.	710
		Ratio Regulator	A ratio regulator is used to control the air/gas ratio. The ratio regulator is a sealed unit that adjusts the gas pressure in ratio with the air pressure. To do this, it measures the air pressure with a pressure sensing line, the impulse line. This impulse line is connected between the top of the ratio regulator and the burner body.	742
		Main Gas Shut-Off Valve Train	Eclipse strongly endorses NFPA as a minimum.	790/791
		Pilot Gas Valve Train	Eclipse strongly endorses NFPA as a minimum.	790/791
		Automatic Shut-Off Valve	Shut-off valves are used to automatically shut off the gas supply on a gas system or a burner.	760
		Orifice Meter	Orifice meters are used to measure flow.	930
		Combustion Air Blower	The combustion air blower provides the combustion air to the burner(s).	610

Symbol	Appearance	Name	Remarks	Bulletin/ Info Guide
		Hermetic Booster	Booster is used to increase gas pressure.	620
		Automatic Butterfly Valve	Automatic butterfly valves are typically used to set the output of the system.	720
		Manual Butterfly Valve	Manual butterfly valve are used to balance the air or gas flow at each burner.	720
		Adjustable Limiting Orifice	Adjustable limiting orifices are used for fine adjustment of gas flow.	728/730
		Pressure Switch	A switch activated by rise or fall in pressure. A manual reset version requires pushing a button to transfer the contacts when the pressure set point is satisfied.	840
		Pressure Gauge	A device to indicate pressure.	940
		Check Valve	A check valve permits flow only in one direction and is used to prevent back flow of gas.	780
		Strainer	A strainer traps sediment to prevent blockage of sensitive components downstream.	
		Flexible Connector	Flexible connectors isolate components from vibration, mechanical, and thermal stresses.	
		Heat Exchanger	Heat exchangers transfer heat from one medium to another.	500
		Pressure Taps	Pressure taps measure static pressure.	

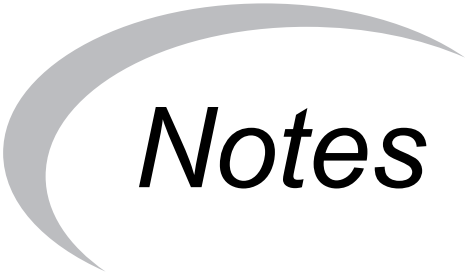

# *Notes*

