

Datasheet

Multi-stage restriction orifice

Rev.2 April 2016

- ✓ Designed to reduce the pressure or the flow of the fluid
- ✓ Used when the target pressure drop cannot be achieved with a single plate
- ✓ Prevent from cavitation as well as important levels of noise or vibration
- ✓ Single or multi-orifice plates assembly
- ✓ Orifice plate design based on ISO5167, BS1042, ASME.MFC.3M industry standards
- ✓ Designed according to ASME B31
- ✓ Calculation of noise level
- ✓ In accordance with the european directive PED 97/23 CE
- ✓ Hydrostatic testings
- ✓ Delivered with all the relevant certificates



Contents

Overview.....	page 2
Technical specifications.....	page 2
Engineering.....	page 3

Restriction orifices are used to reduce the fluid pressure or to restrict the flow rate in a pipe work. The pressure drop produced by forcing the flow through the restriction orifice is calculated accurately taking into account all the relevant operating conditions.

In case the target pressure drop cannot be achieved with a single plate, a multi-stage restriction orifice assembly is required. It allows reducing the pressure in different steps (multiple stages) to achieve the required pressure drop while preventing problems such as noise, vibration and cavitation.

The number and sizing of the different stages depends on the desired pressure drop and on the occurrence of the critical flow, at which point sonic velocity is reached (choked flow). This velocity corresponds to the maximum velocity from which any reduction of pressure is impossible. Thus, a multistage restriction orifice will enable stage reductions in pressure to prevent choked flow from occurring.

Technical specifications

Applications – standards

Standards	ISO5167-1, BS1042, ASME.MFC.3M ASME B31 Manufacturing & welding : ASME9, ASME5, EN288
Fluid temperature	According specifications
Type of fluid	Gas, steam, liquid
Nominal diameters	ND15 to ND1000 (from ½ up to 40 inches) - and beyond according specifications
Maximum operating pressure	Limited by the flange rating - from 150# to 2500#

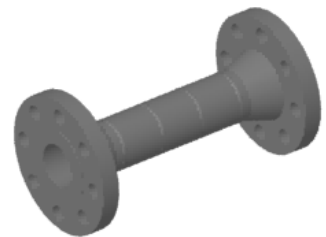

The orifice plate is dimensionally checked in compliance with the manufacturing quality controls. Manufacturing is possible according the european directive PED 97/23 CE requirements.

Features

Noise	To comply with acceptable noise levels (<85dB), design with multi-holes plates
Material	Stainless steel, Carbon steel, Monel alloy, Hastelloys, Inconels, Titanium, PVC, etc

Mounting

Plates assembly	Complete multi-stages system including several plates welded in series in the pipe.
Process connection	Process connection to existing pipe work, between flanges (RF or RTJ) or butt welding.

Technical description

Number of plates	Calculation depending on the process conditions and on the application requirements
Distance between plates	Multiple restriction orifice plates separated by a distance of 1 pipe diameter (nominal diameter of the pipe)
Number of orifice bores	Simple orifice bore or multi-orifice bores in order to lower the noise to an acceptable level (< 85dB)
Traceability	Direct laser marking with a flow direction indicator

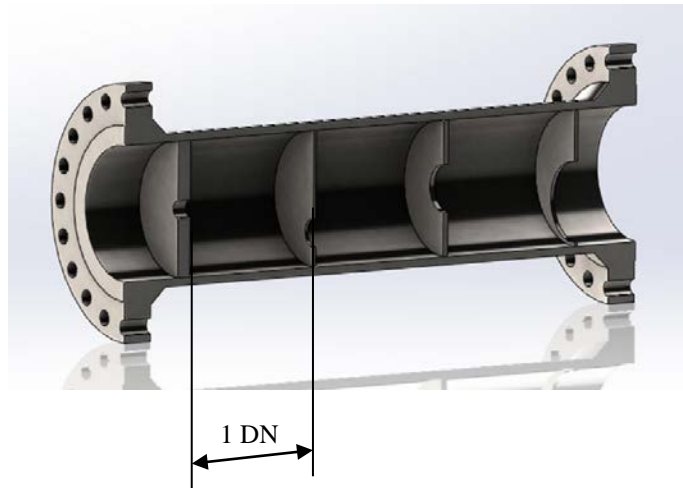

Engineering

Multistage restriction orifices are engineered to meet specific process conditions and requirements. Suitable softwares are used for accurate calculations (orifice bore, thickness of the plate, number of stages, level of noise...), for designing the integral restriction orifice and simulating the fluid flows to check the optimal operation of the device.

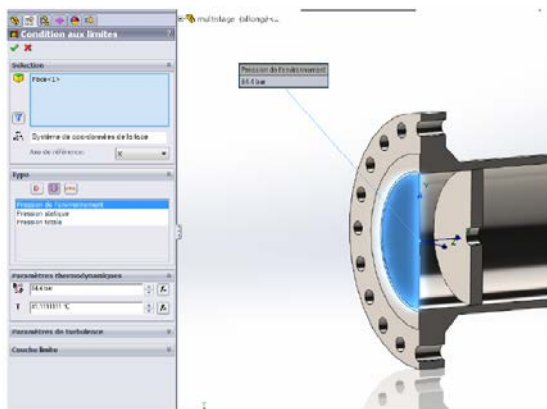

Example of simulation

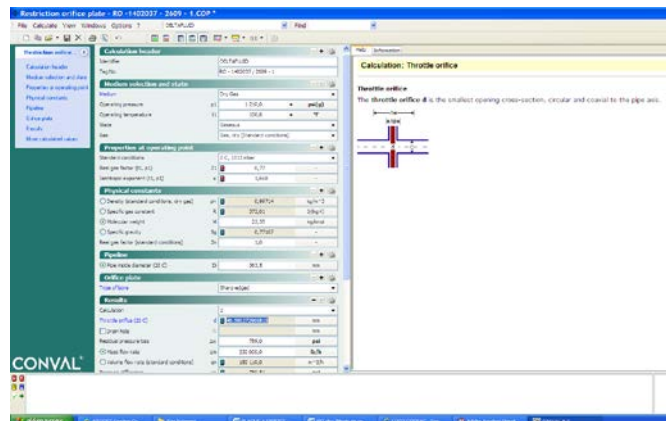

Example of calculation

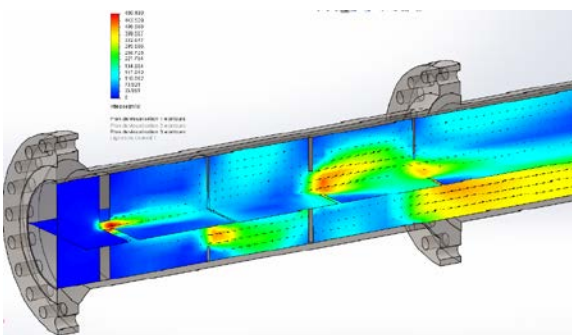

Section view of fluid speeds

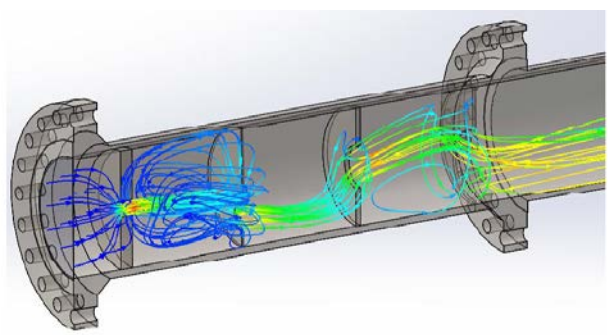

Sectional view of streamlines