



BIFFI

ICON200v4 scores an important goal in the valve/ actuator process diagnostics and advanced maintenance program

Features

- Release 2004 was engineered as an improvement and optimization of the performances of the existing ICON2000 and totally interchangeable with Release 2000
- Actuator operation, setting and diagnostics are available via the integral user-friendly push-button panel
- Bluetooth™, radiofrequency wireless connector based on a qualified Bluetooth™ class 1 module(**)
- Watertight and explosion-proof PDAs are available from Biffi Italia for actuator operation, download of diagnostic info, non-intrusive upgrading of firmware and for maintenance purposes through Bluetooth™
- Enhanced hardware and software performances to offer:
 - advanced maintenance data including reports on the last opening and closing position/torque curves with relative parameters and with direct comparisons with torque signature;
 - detailed and updated information on actuator internal parameters with precise and clear alarm reports, with both General and Recent (partial) log;
 - 'Data logger' function for collecting different types of data for maintenance or diagnostic programs, available both in:
 - RECORDER mode for measurement and memorization of main actuator internal parameters with configurable SAMPLING TIME and START DATE and TIME
 - EVENT mode with memorization of OPEN or CLOSE commands, including indication of source, date and time with configurable START DATE and TIME
- Customized displays:
 - Numeric: 31/2 digits, for the indication of position or torque
 - Graphic: 32x122 dots, for a complete diagnostic user-friendly communication with the operator
 - Backlights
 - Heater
 - 8 selectable languages as standard
- A single enhanced-type terminal board



- Advanced open bus communication protocols:
 - Lonworks
 - Profibus DPV0, DPV1 and Redundant DPV1
 - Foundation Fieldbus
 - Modbus
 - Hart

Diagnostics

Internal circuits continuously monitor the status of the system and elaborate all the information coming from the sensors: diagnostic messages are displayed in one of the available languages, so that there is no need to decipher complicated codes. The set of messages is complete both with alarms and warnings.

(**) US and Italy patented
Bluetooth is a trademark of Bluetooth SIG, Inc., USA

Cost reduction and user-friendliness

The reduced number of mechanical parts ensures higher reliability and lower maintenance costs.

The aluminium alloy highly resistant housing and covers, together with a lower number of joints, have increased Icon capacity to stand up to the most aggressive environments. A double-sealed enclosure assures protection from dust and humidity. The choice of internal components has increased the overall system efficiency (the motor is directly engaged to the gears) lowering the operational cost.

Reduction of training costs is also one of the goals we have achieved through the user-friendliness of the system.

No more codes to decipher: Icon menu is clear and easy, with the possibility to choose one of the available languages (Italian, English, Spanish, Portuguese, French, Turkish, Russian, Norwegian).

Internal sensors

All internal sensors are contactless.

• Torque sensor

The direct measure of the motor speed reports torque with high precision and a resolution of 1% of the nominal torque. Torque detection is based on motor torque vs. speed characteristics, voltage and temperature compensated. The torque vs. speed curve is memorised for each type of motors and in case of motor replacement simply a new configuration from the actuator local control panel is requested.

• Position sensor (US patented)

Controlled by a dedicated microprocessor with low power consumption, it is based on Hall-effect incremental encoder with a resolution of 10° of output shaft rotation.

Rotations in both senses are recognized and counted.

If manually operated during power failure, the position is updated, stored and displayed locally.

• Electronic card: the latest technology

The card is controlled by a Hitachi high performance 16 bit microchip, with a 4 Mb flash memory.

This allows high flexibility and the possibility to be re-programmed in case of need.

All the internal wiring has been considerably reduced.

The modular design of the electronic cards allows high flexibility for a great variety of combinations.

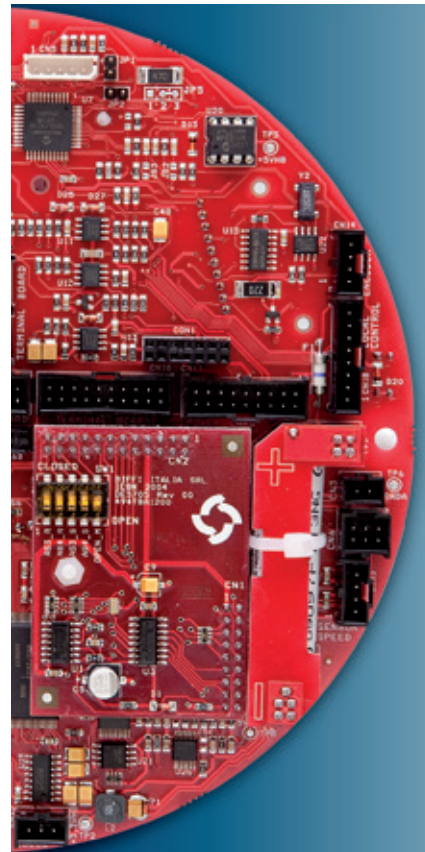

ICON2000v4 software: PC and PDA Manager

A dedicated software for PC and PDA is available for ICON 2000v4.

With the new software, total control of ICON2000v4 is always available in your hands and in your office. With a smart user-friendly graphic interface, all the actuator information, set-up, configuration data, diagnostic messages and data logger info are available for visualisation, analysis and reconfiguration from your PDA or PC.

PDA Manager

The PDA Manager will transform your common PDA or dedicated industrial PDA into a strong tool for the complete control, set-up and diagnostics of the ICON2000v4 actuators installed in your plant. A user-friendly graphic interface reproduces the actuator local control panel for an easy control of the valve and offers several tools for a complete analysis of the actuator status.

ICON2000v4 supports Bluetooth™ wireless non-intrusive communication. In particular, with Bluetooth™ communication it is possible to communicate with the actuator within a distance of several meters from any angle.

In addition, it is possible to connect to all the actuators within operation distance with one single PDA.

All the data exchanged with the actuator on-field can be shared with your PC in the office through the PC Manager software. Connect the PDA to the PC with the ActiveSync program and download all the data.

Standard PDA minimum basic requirements

- Operating systems: Windows. Mobile™ 2003 for Pocket PC
- Bluetooth™ interface module
- Processor: 266 MHz processor
- Memory: 32 MB SDRAM minimum
- 3.5" TFT display with 16k colour depth.

Ex-hazardous area industrial PDA technical characteristics

- High performance industrial PDA based on Windows. Mobile™, with compact external dimensions, an integrated WLAN, USB and Bluetooth™ port.
- Meets different industry requirements operating both inside and outside of Ex-hazardous areas.

Basic features

- Ergonomic design to facilitate operations without fatigue during continuous use;
- High resolution colour display, readable even in the most unfavourable light conditions;
- Protection from static electricity, water and dust;
- Shockproof housing (non-corroding);
- Standard keyboard with navigation field and programmable keys;
- 3.5" TFT display with 16k colour depth.

Technical data sheet

- Operating systems: Windows. Mobile™ 2003 Premium-Software for Pocket PC;
- Processor: 400 MHz processor based on Intel technology;
- Power supply: Rechargeable battery;
- Standard delivery: Unit, Charger, Operating instructions, safety instruction, software CD;
- Ex-Data: Ex-hazardous application intrinsically safe type and suitable for different gas and dust atmospheres, ATEX or other certification.

PC Manager

PC Manager transforms your PC into a strong tool for the control, set-up and diagnostics of ICON2000v4 actuators.

A user-friendly graphic interface reproduces the actuator local control panel for an easy control of the valve and offers several tools for a complete analysis of the actuator status.

ICON2000v4 supports Bluetooth™ non-intrusive communication or serial communication (intrusive).

The same interfaces available with PDA Manager with an improved graphic release (considering the larger screens available on PCs) are easily synchronisable with the PDA:

Actuator control



Actuator maintenance and diagnostic informations

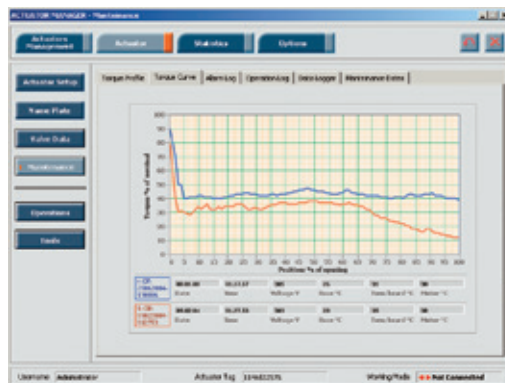

Actuator set-up



Actuator data logger



PC Manager software supports Bluetooth™, or serial communication with actuator communication (Windows 2000, XP operating systems and Windows 7).

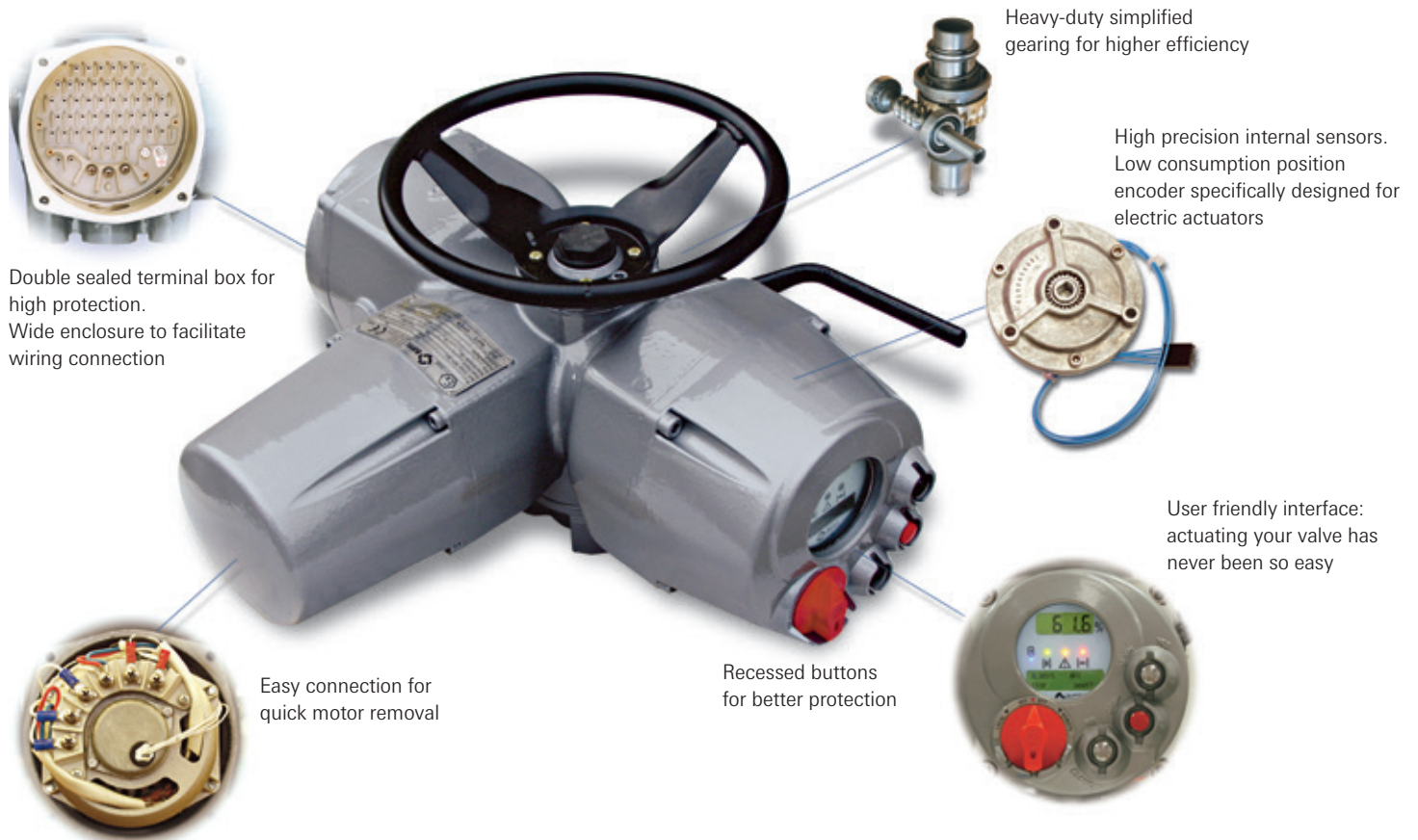



High profile standards: all the major features have been included in the base version

The base version is an intelligent actuator with hardwired (i.e. point to point) connection.

- **Automatic phase correction**

The valve will be protected as the system automatically recognizes and corrects phases preventing any unforeseen error in rotation sense.

- **Phase failure correction**

In case of loss of one of the phases, this feature prevents the motor from overheating. The minimum time to set the alarm on is 100 ms, in order to prevent the system from being influenced by casual oscillations. In case of loss of one phase during motor running, the actuator will reach the end-of-travel position before setting the alarm condition and de-energizing the actuator.

- **Motor thermostat**

If during operation the temperature of the motor overrides the security limits, a thermostat will set the alarm condition and the command signal will be inhibited.

- **Jammed valve protection**

If, after a command (close/open), the valve position does not change within a pre-set time, an alarm condition is set and the command signal will be inhibited. The pre-set time can be any time within the interval 2 to 100 seconds.

- **Anti-hammer protection**

This feature will protect both the motor and the valve. If a torque limit is reached it will prevent the valve from moving in the same direction which has caused the torque limit.

- **Instantaneous reversal protection**

When the actuator is operating in one direction and an immediate command for a reverse direction is set, unpredicted current surges arise with possible damages to the motor. To prevent such problems, a delay between the opposite commands can be programmed from 500 ms to 5 seconds.

- **Warnings**

Warning signals become active when the operating conditions are close to a critical alarm level. Warning is displayed but operation is not interrupted.

- **Remote controls**

Three different configurations are available:

- 4 wires (OP, CL, Stop, C/latched)
- 3 wires (OP, CL, C/push-to-run or latched with instant reverse)
- 2 wires (NO contact to open or reverse)

- **Control voltage**

- 24 V DC, internal supply
- 20 to 125 V DC, external supply
- 20 to 120 V AC, external supply

- **Remote output contacts**

Seven voltage-free latching relays and one change over single side stable relay are available for remote indication. The latching relays can all be configured as Normally Open or Normally Closed contact.

Each relay can be configured to switch for one condition included in the following list.

- Fully open
- Fully closed
- Intermediate position
- Position \geq XX %
- Position \leq XX %
- Actuator opening
- Actuator closing
- Motor running
- Blinker
- Local selected
- Remote selected
- Local stop active
- ESD active
- Manual operation
- Motor over temperature
- Torque alarm
- Torque alarm in opening
- Torque alarm in closing
- Jammed valve alarm
- Jammed valve in opening
- Jammed valve in closing
- Mid-travel alarm
- Warning
- Low battery

• **Emergency shutdown (ESD)**

When an ESD signal is received (i.e. in an emergency situation), the actuator performs the ESD programmed action. It can be configured to override any of the following conditions:

- Selector in LOCAL
- Selector in OFF
- Motor temperature alarm
- Local STOP pushbutton
- Torque alarm
- 2 speed timer

and it can be programmed to one of the following:

- Stay put
- Move to open position
- Move to close position
- Move to pre-set position
- Interlock controls. Two interlock inputs are available to inhibit actuator movement in open or close direction.

• **Monitor relay**

When the actuator is not available for remote control, an alarm condition is set. The contact type is a change-over voltage-free. The monitor relay is normally energized and will be de-energized on:

- Loss of power
- Loss of one phase
- Electrical contactor failure
- Internal temperature alarm
- Position sensor
- Speed sensor
- Configuration error
- Hardware error
- Mid-travel alarm

The following conditions can be individually configured to switch over the monitor relay:

- Loss of one phase
- Local stop activated
- Local selector switch in LOCAL/OFF
- Motor temperature alarm
- Torque alarm
- Jammed valve
- Manual operation
- ESD signal
- Low battery

• **Contactor failure**

As one of the vital parts of the actuators, contactors are continuously monitored. If a malfunction is detected an alarm is set and the command is inhibited.

• **Maximum torque alarm**

During torque operation, if the current torque exceeds the relevant set value, the actuator command is inhibited and an alarm condition is set.

• **Opto-coupled remote controls**

Actuator may be remotely controlled by 4, 3 or 2 wires, depending on the connection made on terminal board. Various options are available: latched, momentary, etc...

• **Torque alarm by-pass**

During opening command, starting from open/closed position it is possible to set an interval from 0% to 20% of the total stroke where torque alarm is ignored. This will allow the actuator to win the Break-to-open torque.

• **High/Low electronic temperature**

Through a semiconductor-based temperature sensor, the temperature in the electronic card is detected and an alarm condition is set if the lowest/highest limits are reached.

Local operator interface

The local interface has been designed to be easily operated and to supply a complete and clear set of information.

It is composed of

- A padlockable three-position selector for LOCAL/OFF/REMOTE operation selection
- Three pushbuttons for both local OPEN/CLOSE/STOP controls and menu navigation
- 2 customised displays, with backlight and heater:
 - numeric 3 1/2 digit display for torque and position indication
 - graphic display supporting various character sets
- 2 bi-coloured led (green/red) to indicate fully open/closed/intermediate
- 1 bi-coloured (red/yellow) to indicate alarm/warning state
- 1 blue led to indicate Bluetooth connection active
- Class 2 Bluetooth module available for wireless connection to PDA or PC

All buttons are recessed for protection from accidents or misuse. The local push-buttons OPEN/CLOSE can be configured with 3 options: latched, latched + instant reverse, or push-to-run.

Through the local interface the field operator can enter a basic configuration menu which allows to set the following parameters:

Base parameters

- End of travel position in opening/closing
- Opening/closing torque values
- Position/torque display
- Opening/closing by torque/position
- Output contacts
- ESD feature
- Remote/Local control feature

Extended parameters

- Timer parameters
- Position servo-amplifier parameters
- Fieldbus interface parameters
- Data logger
- Maintenance date
- Diagnostic info
- PID parameters
-

The configuration menu is password protected.

Three LEDs with settable different colors to indicate valve opening/closing, alarms, warnings, mid-travel and end-of-the-stroke positions.

Added extra features

• Predictive maintenance

Some of the most vital parts of the actuator are monitored:

- contactor cycles count
- torque trend
- alarms data log

• Timer Function Module (TMR)

It allows for partial or complete timer controlled valve stroke.

Through the local/remote interface the following can be set:

- if it has to be active during opening or closing operation
- ON time, from 1 to 200 sec max, with resolution of 1 sec.
- OFF time, from 1 to 200 max, with resolution of 1 sec.
- percentage of position when timer starts on opening
- percentage of position when timer starts on closing

• Electronic card identification message

Base, terminal board and 4-20 mA card are clearly identified with a 64 character message for fast track including:

- Biffi assembly code
- Assembly serial number
- Manufacturing date
- Software and Hardware versions
- Description

• Data log

ICON2000 is complete with an exhaustive data log system which will allow for storage of main events which are occurring during actuator operation. The data monitored are:

Alarms

- Last 64 alarms and date
- Last 64 warnings and date

Torque profiles

Torque curves and torque signature: in the memory of ICON2000 are memorized

- | | |
|---|--|
| <input type="checkbox"/> Breakout reference torque in opening | <input type="checkbox"/> The last 100 torque versus position curves in opening |
| <input type="checkbox"/> Peak running reference torque in opening | <input type="checkbox"/> The last 100 torque versus position curves in closing |
| <input type="checkbox"/> Ending reference torque in opening | <input type="checkbox"/> The torque signature in opening |
| <input type="checkbox"/> Breakout torque in opening | <input type="checkbox"/> The torque signature in closing |
| <input type="checkbox"/> Peak running torque in opening | |
| <input type="checkbox"/> Ending torque in opening | The above data can be read from ICON2000 to PC or PDA by A-Manager and viewed and compared as graph or Excel tables. |
| <input type="checkbox"/> Breakout reference torque in closing | |
| <input type="checkbox"/> Peak running reference torque in closing | |
| <input type="checkbox"/> Ending reference torque in closing | |
| <input type="checkbox"/> Breakout torque in closing | |
| <input type="checkbox"/> Peak running torque in closing | |
| <input type="checkbox"/> Ending torque in closing | |
| <input type="checkbox"/> Date of the last 'set torque reference' | |
| <input type="checkbox"/> Date of last torque profile in opening | |
| <input type="checkbox"/> Date of last torque profile in closing | |

Operations

- Opening time of the last stroke
- Closing time of last stroke
- Total contactor operations
- Motor run time
- Time out without electrical power
- Utilisation rate
- Torque alarm number
- Motor temperature alarm number
- Min and max temperature of motor and electronics
- Recent contactor operations
- Recent motor run time
- Recent time without electrical power
- Recent utilisation rate
- Recent torque alarm number
- Recent motor temperature alarm number
- Recent min and max temperature of motor and electronic

Maintenance data

- Last maintenance date
- Next maintenance date
- Date of the last 'clear recent data log'
- Start-up date

Name plate

The basic information of the actuator is electronically stored in a non-volatile memory:

- Serial number
- Actuator size
- Nominal torque
- Actuator speed
- Power supply
- Motor rating
- Motor duty
- Motor poles
- Motor type
- Motor current
- Test date
- Wiring diagram
- Enclosure
- Certificate
- Lubricant
- HW version
- SW version

Valve data

To identify the valve and its function in the process, the valve manufacturer/end user can enter the following data:

- valve tag name
- valve serial number
- valve manufacturer
- break to open torque
- max stem thrust
- valve coupling type

For such information 28 characters are available.

Customizable torque profiles

In some applications you need to set different torque profiles for operating the valve.

For this reason we have introduced a 3-point torque profile.

Sleep mode function (for DC models only)

A specific sleep mode function is set up for DC actuators in order to save power available in the plant. All functionalities are kept in stand-by mode when not requested and immediately available on demand.



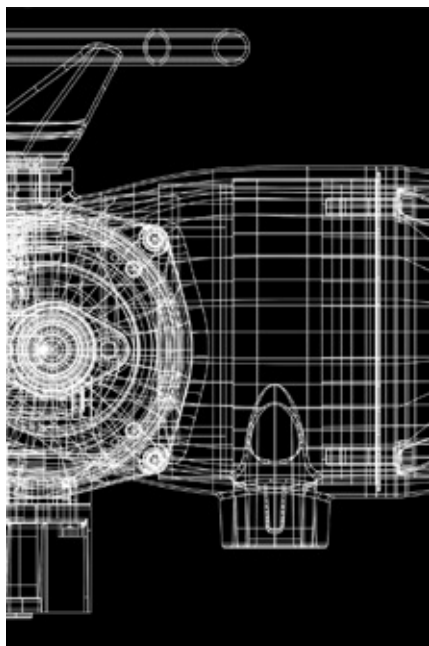

The following is a description of our ICON2000 standard features/options and working conditions. For whatever you may require which is not listed below, please contact Biffi Sales offices.

Voltage ratings

The actuator can accept the following voltage supplies:

- Three phase:
 - 50 Hz 230, 240, 380, 400, 415, 440, 460, 480, 500, 690 V
 - 60 Hz 208, 280, 380, 460, 480, 575 V
- Single phase
 - 110, 115, 220, 240 V at 50, 60 Hz
- Direct Current
 - 24, 48, 110, 240 V

Tolerance on fluctuations

- Voltage: $\pm 10\%$ continuous; $+10\%$ - 15% intermittent
- Frequency: $\pm 2\%$

Working temperature

- The standard range is -30°C to $+85^{\circ}\text{C}$
- Extended ranges -40°C to $+65^{\circ}\text{C}$
- Special low temperature range version -55°C to $+65^{\circ}\text{C}$

Storage temperature

- From -55°C to $+85^{\circ}\text{C}$

Environmental protections

- **Only waterproof**
IP 68 according to IEC 529 and CEI EN60529 (15 m dept/90 hours), or alternatively NEMA 4, NEMA 4X and NEMA 6 according to NEMA ICS6
- **Standard explosionproof degree**
EEx-d IIB T4 according to EN50014, EN50018 and EN50281-1-1
IP 68 according to IEC 529 and CEI EN60529 (15 m dept/90 hours), or alternatively NEMA 4, NEMA 4X and NEMA 6 according to NEMA ICS6
- **Optional explosionproof degree:**
 1. EEx-d IIC T4 according to EN50014, EN50018, EN50019 and EN50281-1-1. Working temperature range: -25°C to $+65^{\circ}\text{C}$.
IP 68 according to IEC 529 and CEI EN60529 (15 m dept/90 hours), or alternatively NEMA 4, NEMA 4X and NEMA 6 according to NEMA ICS6
 2. EEx-d IIC T4 ($-25^{\circ}\text{C}/+65^{\circ}\text{C}$) (consult factory)
EEx-de IIC T4 ($-25^{\circ}\text{C}/+65^{\circ}\text{C}$) (consult factory)
EEx-de IIB +H2 T4 ($-25^{\circ}\text{C}/+65^{\circ}\text{C}$) (consult factory)
IP 68 according to IEC 529 and CEI EN60529 (15 m dept/90 hours), or alternatively NEMA 4, NEMA 4X and NEMA 6 according to NEMA ICS6
 3. US/Canada Standards:
FM/CSA Class I, Division 1, Groups C and D
Class II, Division 1, Groups E, F and G
Class III, Division 1, Groups E, F and G
Temperature classes: T4A, -55°C to $+60^{\circ}\text{C}$
T4, -55°C to $+70^{\circ}\text{C}$
NEMA 4, 4X and 6



Safety compliance

- **Electromagnetic compatibility directive (EMC)**
ICON2000 actuators conform to the requirements of EMC Directive 2004/108/EC and further amendments.
- **Low voltage directive (LV)**
ICON2000 actuators conform with Low Voltage Directive 2006/95/EC and further amendments by the application of EN60204-1 1993.
- **Machinery directive**
ICON2000 actuators comply with the provision of Machinery Directive 2006/42/EC.
- **ATEX directive (94/9/EEC)**
ICON2000 v4 actuators are certified according to Ex II 2 GD.

Test summary

- **Life test**
Standard ICON2000 life test is based on AWWA 540-93 for a minimum of 10,000 cycles.
- **Vibration test**
ICON2000 are certified as per IEC 60068-2-6- Appendix B (plant induced): frequencies from 1 to 500 Hz (in 3 axes) with 2.0g peak acceleration. Sweep cycles in each axis: 10.
- **Seismic test**
ICON2000 are tested in accordance with IEC 60068-2-57. Frequencies from 1 to 35 Hz (in 3 axes) with max 2.0g peak acceleration. Verification of structural integrity at 5g. Endurance of oscillogram: 30 seconds.

• Environmental test

ICON2000 are tested according to the following standards: IEC 68-2-1 (cold) up to -55°C, IEC 68-2-2 (dry heat) up to +85°C, IEC 68-2-3 (damp heat) up to +40°C with 93% relative humidity.

• Salt spray test

ICON2000 external coating is tested for resistance to salt spray for 1,500 hours according to ASTM B117/IEC 68-2-11.

• Noise test

ICON2000 are tested according to EN21680. Noise level is less than 65 dB (grade A) at 1m distance.

Motors

Base-version ICON2000 actuators are equipped with three-phase asynchronous, squirrel cage, induction-type low-inertia balanced motors. For single phase or direct current supply, a special interface allows the use of conventional asynchronous motors. The open frame is protected by an Explosionproof / Waterproof cover fixed on the actuator housing. Internal protection by a temperature sensor, inserted in the motor windings.

The motor flange is directly coupled to the actuator housing with internal flying leads wired to an intermediate terminal board. Electric motors are supplied with insulation class H as standard with dedicated speed and temperature sensor.

Cinematic reduction chain and lubrication

Motor power is transmitted to the output hollow shaft directly via a high torque capability and high efficiency worm shaft/worm wheel reduction without any interposition of spur or helical gears. Output hollow shaft is with teeth termination in order to transmit only a torque to the stem nut. Lubrication is through an oil bath with two points for filling and draining.

Manual override

All actuators are provided with a hand-wheel (without external spokes) for manual operation. The de-clutching mechanism is designed so that motor operation always has priority over manual operation. Whenever the motor is started, the hand mechanism will automatically disengage without engaging the operator. The de-clutch lever is padlockable in two positions (only electrical or only manual) to prevent undesired operation.

Terminal block

Terminal block is located in a double sealed enclosure.

The terminal block is provided with the following terminations and accessories:

- 3 terminals for power supply
- 46 terminals for controls
- 2 for DC external supply
- 2 for low voltage (max 230 V) external supply
- 1 external earth
- 1 external neutral

Cable entries

Three cable entries are supplied as standard.

One extra entry is optionally available.

The standard thread is NPT and diameter is:

- one with 1 1/2"
- two with 1"
- one with 3/4" (optional)

ISO Rc 7/1, ISO metric BS3643 and DIN 40430/PG and different diameters are available as optional.

Data logger

'Data logger' is available for collecting different types of data useful in maintenance or diagnostic programs. Since the amount of collected data is quite large, the data logger must be downloaded onto a Pc/Pda through Irda or Bluetooth™ connection to be viewed.

The main functions of the Data logger are:

- RECORDER mode: measurement and memorisation of main voltage supply (V), motor temperature (C°), electronics compartment temperature (C°), with configurable sampling time and start date and time (up to 256 sets of measures can be memorised)
- EVENT mode: memorisation of Open or Close commands, with indication of source, date and time. Configurable Start date and time. Up to 128 events can be memorised.

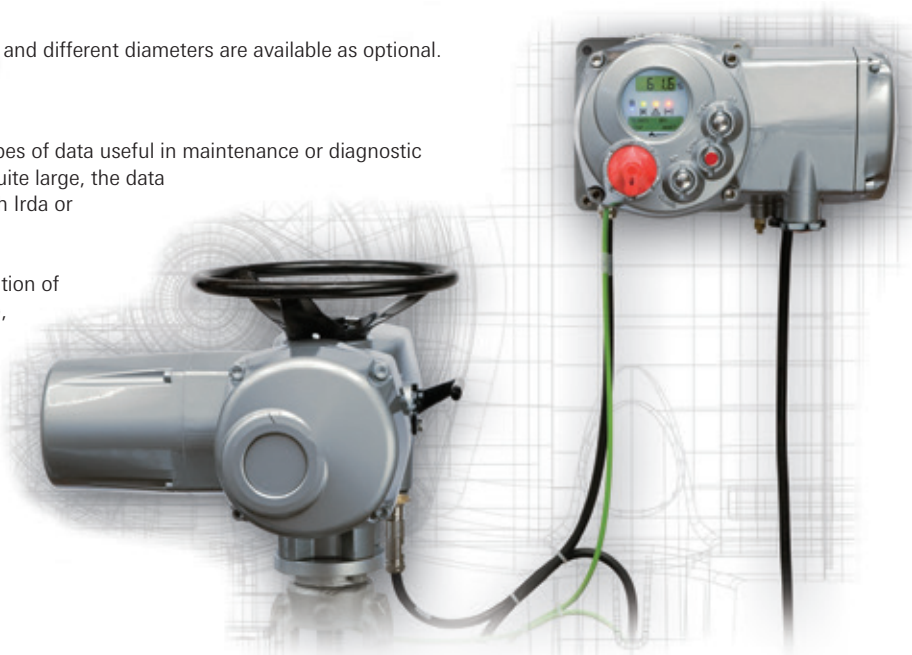



Fieldbus interfaces

ICON2000 modular design is easily upgraded from base-to-base to bus versions. All that is needed is to add the relevant plug-in card. ICON2000 flexible interface allows connection to the major field bus available on the market:
Foundation Fieldbus
Profibus DPV0, DPV1 and redundant DPV1
LonWorks
Hart
Modbus

Options

- DTM (Device Process Manager) for process control system with FDT interface for Profibus DPV1.
 - EDD (Electronic Device Description) for simatic PDM for Profibus DPV1
 - Removable Profibus Connection
- Please ask our Sales people for specific requirements.

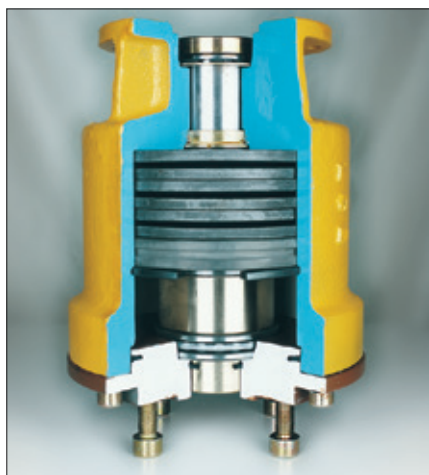

A large variety of optional modules can be added to the base version. If the option you are looking for is not listed below, please contact Biffi.

Position Servoamplifier Module (PSM)

The module is necessary for actuators in modulating and inching duty. It drives the motor through pulses at constant frequency and duration proportional to the position error, following an externally set analogical point signal.

The basic features are:

Input: 4-20 mA or 0-20 mA with galvanic insulation

Output: 4-20 mA with galvanic insulation for position or torque re-transmission.

Three additional SPST output contacts to be configured 'make or break'.

2 interlock inputs.

Position Analogue Retransmission Module (APTM)

This card gives a 4-20 mA galvanically insulated module for position or torque retransmission. It is easily plugged in on the base card with no need for dedicated tools.

The module can be configured to retransmit the output torque in place of the actuator position.

Solid state power switch over temperature

(only for heavy modulation duty version)

It detects power card maximum temperature condition and sets the relevant alarm.

Extended temperature ranges

-40/+70°C by use of extended range components

-55/+70°C by use of a heating source for internal electronic components, powered by external supply.

Anti-condensate heater

The internal modules provide enough power to grant anti-condensation protection for general applications. But when the environment air humidity reaches critical levels, an additional heater (10 Watt - 1500 Ohm, with external power supply) may be supplied on request.

Battery

Auxiliary batteries can be provided in an intrinsically safe enclosure.

With auxiliary batteries it will be possible to remotely transmit position also in case of power failure.

Hand-wheel with reduction gearing

Side hand-wheel with additional reduction, with engagement lever.

The reduction on the manual operation reduces the torque at the hand-wheel.

This provides less 'rim-pull' force for the operator.

The following ratios are applicable:

model	ratio
030	10:1
040	13:1
050	17:1

Special couplings

To be able to cope with different applications and working condition, two special couplings are available:

- The linear coupling was designed for the motorization of valves with stem linear movement and no anti-rotational devices on the stem (e.g. application on modulating globe valves). This type of coupling converts multi-turn actuator rotational motion into linear motion: in this way the motorization is extremely simple and compact.
- Spring-compensated coupling ASC type. The spring coupling block has its best application on actuators for wedge and globe valves working at high temperatures. The trim of valves working at temperatures higher than 450°C and subjected to large temperature changes undergoes expansions and contractions that are very dangerous to the valve and to the actuator thrust coupling. If, on the other hand, low temperatures are causing contractions, valve unseating could occur. The spring-compensated coupling is designed to cope with both high and low temperatures: the spring cups allow the stem nut to move axially. The same coupling can also be used in case of high speeds, as the springs reduce the over-strokes effects by absorbing the kinetic energy.

ICON2000 series overall dimensions

Model	A	a ₁	a ₂	B	b ₁	b ₂	ØC	F	H	h ₁	h ₂	h ₃	Mass Kg
ICON-010	485	325	160	565	273	292	300	F10	324	142	152	210	32
ICON-020	597	347	160	583	283	300	500	F14	374	161	161	240	45
ICON-030	699	399	160	625	313	312	600	F14	431	185	175	270	70
ICON-040	815	455	170	690	318	372	720	F16	478	196	191	291	86
ICON-050	938	508	180	755	363	392	860	F25	549	223	218	336	110

Model 010

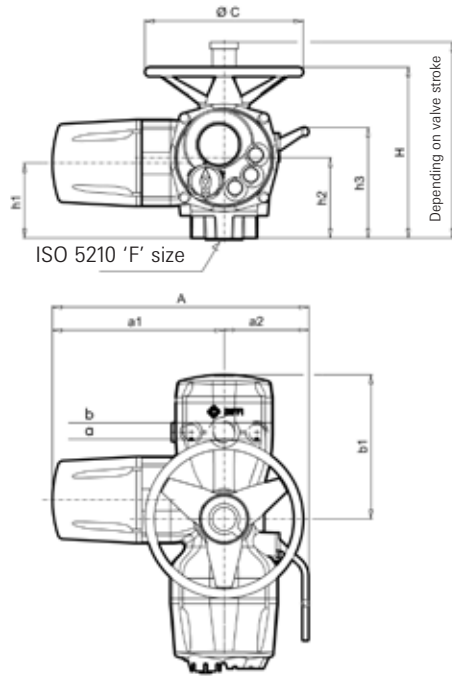

Models 020/030/040/050

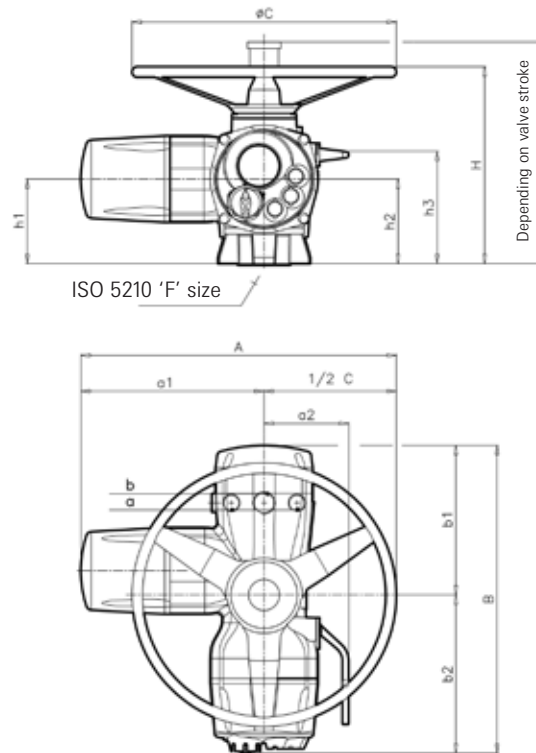

Standard cable entries:

a = 1" NPT

b = 1 1/2" NPT

ICON2000 series overall dimensions (with reduced manual override)

Model	A	a ₁	a ₂	B	b ₁	b ₂	ØC	H	h ₁	h ₂	h ₃	Mass Kg
ICON-030	648	399	249	625	313	312	300	486	171	182	263	78
ICON-040	723	455	268	690	318	372	400	558	196	191	284	94
ICON-050	779	508	271	755	363	392	500	693	223	218	336	118

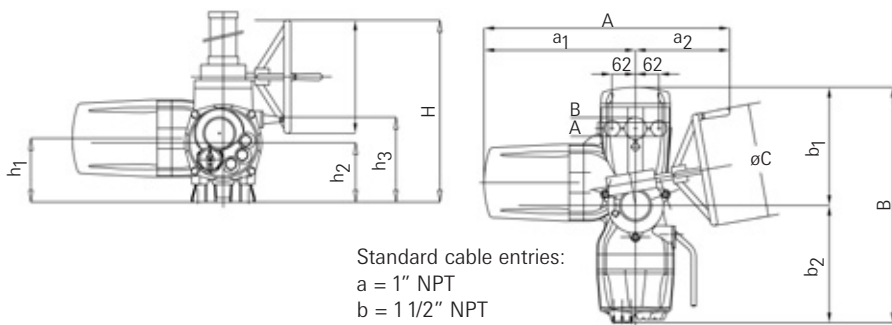

Standard cable entries:

a = 1" NPT

b = 1 1/2" NPT

* The information herein contained is reserved property of Biffi and is subject to being modified without notice.

Multiturn Actuator Performances with 3-phase motors ⁽⁴⁾ - ON/OFF or Inching service

Model ⁽¹⁾	Nom. torque ⁽²⁾ (100%) (Nm)	Min. torque (Nm)	Max. torque ⁽³⁾ (Nm)	RPM ⁽⁵⁾ (50 Hz)	RPM ⁽⁵⁾ (60 Hz)	Motor type	Motor power (KW) at 50 Hz	Motor power (KW) at 60 Hz	R
ICON-010/30-**	30	12	45	12	14	SM00	0.030	0.036	40:1
ICON-010/30-**	30	12	45	18	22	SM01	0.046	0.055	40:1
ICON-010/30-**	30	12	45	24	29	SM10	0.071	0.085	20:1
ICON-010/30-**	30	12	45	36	43	SM11	0.106	0.127	20:1
ICON-010/30-**	30	12	45	48	58	SM04	0.142	0.170	20:1
ICON-010/30-**	30	12	45	72	86	SM05	0.213	0.256	20:1
ICON-010/30-**	30	12	45	144	173	SM06	0.426	0.511	20:1
ICON-010/90-**	90	36	135	12	14	SM10	0.071	0.085	40:1
ICON-010/90-**	90	36	135	18	22	SM11	0.106	0.127	40:1
ICON-010/90-**	90	36	135	24	29	SM12	0.122	0.146	20:1
ICON-010/90-**	90	36	135	36	43	SM13	0.184	0.221	20:1
ICON-010/90-**	90	36	135	48	58	SM14	0.286	0.343	20:1
ICON-010/90-**	90	36	135	72	86	SM15	0.367	0.440	20:1
ICON-010/90-**	90	36	135	144	173	SM16	0.735	0.882	20:1
ICON-020/180-**	180	72	270	12	14	SM12	0.122	0.146	40:1
ICON-020/180-**	180	72	270	18	22	SM13	0.184	0.221	40:1
ICON-020/180-**	180	72	270	24	29	SM14	0.286	0.343	40:1
ICON-020/180-**	180	72	270	36	43	SM15	0.367	0.440	40:1
ICON-020/180-**	180	72	270	48	58	SM21	0.526	0.631	20:1
ICON-020/180-**	180	72	270	72	86	SM22	0.789	0.947	20:1
ICON-020/180-**	180	72	270	144	173	SM23	1.470	1.764	20:1
ICON-030/360-**	360	144	540	12	14	SM21	0.526	0.631	80:1
ICON-030/360-**	360	144	540	18	22	SM32	0.500	0.600	40:1
ICON-030/360-**	360	144	540	24	29	SM21	0.526	0.631	40:1
ICON-030/360-**	360	144	540	36	43	SM22	0.789	0.947	40:1
ICON-030/360-**	360	144	540	48	58	SM30	1.123	1.348	20:1
ICON-030/360-**	360	144	540	72	86	SM23	1.470	1.764	40:1
ICON-030/360-**	360	144	540	144	173	SM31	3.368	4.042	20:1
ICON-040/720-**	720	288	1080	12	14	SM30	1.123	1.348	80:1
ICON-040/720-**	720	288	1080	18	22	SM44	0.840	1.008	40:1
ICON-040/720-**	720	288	1080	24	29	SM30	1.123	1.348	40:1
ICON-040/720-**	720	288	1080	36	43	SM40	1.684	2.021	40:1
ICON-040/720-**	720	288	1080	48	58	SM41	1.939	2.327	20:1
ICON-040/720-**	720	288	1080	72	86	SM31	3.368	4.042	40:1
ICON-040/720-**	720	288	1080	144	173	SM42	5.818	6.982	20:1
ICON-050/1440-**	1440	576	2160	12	14	SM41	1.939	2.327	80:1
ICON-050/1440-**	1440	576	2160	18	22	SM40	1.684	2.021	80:1
ICON-050/1440-**	1440	576	2160	24	29	SM41	1.939	2.327	40:1
ICON-050/1440-**	1440	576	2160	36	43	SM43	2.885	3.462	40:1
ICON-050/1440-**	1440	576	2160	48	58	SM50	3.879	4.655	20:1
ICON-050/1440-**	1440	576	2160	72	86	SM42	5.818	6.982	40:1
ICON-050/1440-**	1440	576	2160	144	173	SM51	11.636	13.963	20:1

Notes

1. The ** are to be replaced by RPM value at selected frequency (50 or 60 Hz)
2. Nominal output torque settable from 40% (minimum torque) to 100% of indicated value
3. Theoretic max output torque. The actual max output torque is a function of speed and motor power supply and may vary from 1.4 to 2 times nominal output torque
4. The above performances are referred to ON/OFF S2-15' or INCHING S4-25%-60 starts/hour duties (IEC34-1)
5. Referred to Running torque = 40% Nominal torque.

Multiturn Actuator Performances with 3-phase motors ⁽⁴⁾ - Modulating service

Model ⁽¹⁾	Nom. torque ⁽²⁾ (100%) (Nm)	Min. torque (Nm)	Max. torque ⁽³⁾ (Nm)	RPM ⁽⁵⁾ (50 Hz)	RPM ⁽⁵⁾ (60 Hz)	Motor type	Motor power (KW) at 50 Hz	Motor power (KW) at 60 Hz	R
ICON-010/30-**	30	12	45	12	14	TM00	0.030	0.036	40:1
ICON-010/30-**	30	12	45	18	22	TM01	0.046	0.055	40:1
ICON-010/30-**	30	12	45	24	29	TM10	0.071	0.085	20:1
ICON-010/30-**	30	12	45	36	43	TM11	0.106	0.127	20:1
ICON-010/30-**	30	12	45	48	58	TM04	0.142	0.170	20:1
ICON-010/30-**	30	12	45	72	86	TM05	0.213	0.256	20:1
ICON-010/30-**	30	12	45	144	173	TM06	0.426	0.511	20:1
ICON-010/90-**	90	36	135	12	14	TM10	0.071	0.085	40:1
ICON-010/90-**	90	36	135	18	22	TM11	0.106	0.127	40:1
ICON-010/90-**	90	36	135	24	29	TM12	0.122	0.146	20:1
ICON-010/90-**	90	36	135	36	43	TM13	0.184	0.221	20:1
ICON-010/90-**	90	36	135	48	58	TM14	0.286	0.343	20:1
ICON-010/90-**	90	36	135	72	86	TM15	0.367	0.440	20:1
ICON-010/90-**	90	36	135	144	173	TM16	0.735	0.882	20:1
ICON-020/180-**	180	72	270	12	14	TM12	0.122	0.146	40:1
ICON-020/180-**	180	72	270	18	22	TM13	0.184	0.221	40:1
ICON-020/180-**	180	72	270	24	29	TM14	0.286	0.343	40:1
ICON-020/180-**	180	72	270	36	43	TM15	0.367	0.440	40:1
ICON-020/180-**	180	72	270	48	58	TM21	0.526	0.631	20:1
ICON-020/180-**	180	72	270	72	86	TM22	0.789	0.947	20:1
ICON-020/180-**	180	72	270	144	173	TM23	1.470	1.764	20:1
ICON-030/360-**	360	144	540	24	29	TM21	0.526	0.631	40:1
ICON-030/360-**	360	144	540	36	43	TM22	0.789	0.947	40:1
ICON-030/360-**	360	144	540	48	58	TM30	1.123	1.348	20:1
ICON-030/360-**	360	144	540	72	86	TM23	1.470	1.764	40:1
ICON-030/360-**	360	144	540	144	173	TM31	3.368	4.042	20:1
ICON-040/720-**	720	288	1080	24	29	TM30	1.123	1.348	40:1
ICON-040/720-**	720	288	1080	36	43	TM40	1.684	2.021	40:1
ICON-040/720-**	720	288	1080	72	86	TM31	3.368	4.042	40:1

Notes

1. The ** are to be replaced by RPM value at selected frequency (50 or 60 Hz)
2. Nominal output torque settable from 40% (minimum torque) to 100% of indicated value
3. Theoretic max output torque. The actual max output torque is a function of speed and motor power supply and may vary from 1.4 to 2 times nominal output torque
4. The above performances are referred to ON/OFF S2-30' or MODULATING S4-25%-600 starts/hour duties (IEC34-1)
5. Referred to Running torque = 40% Nominal torque.

Notes to couplings type A

- $\varnothing d_6$ = Max threaded stem acceptance
- $\varnothing d_x$ = The maximum accepted diameter described by the key
- F_{nom} = The max thrust applicable to the ICON2000 block type 'A' in dynamic conditions with torque control set at 100%
- F_{max} = The max thrust applicable to the ICON2000 block type 'A' in static conditions with manual override or with motor in stall torque

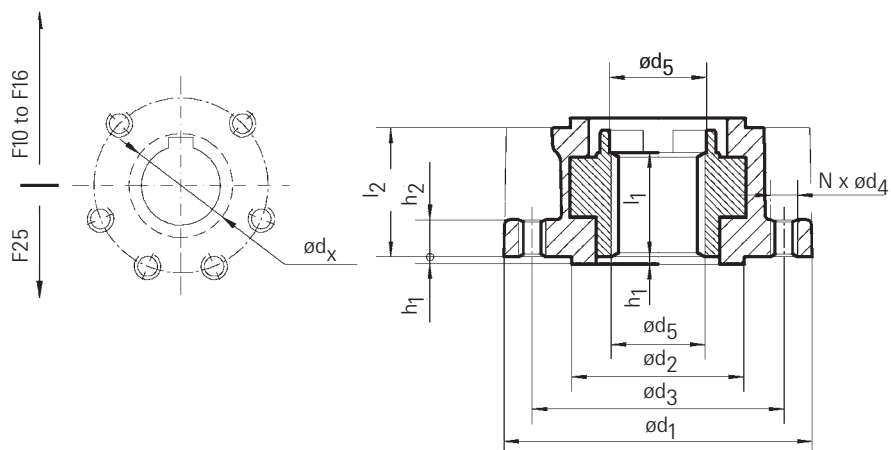

Model	010	020	030	040	050
ISO 5210	F10	F14	F14	F16	F25
F_{nom} (KN)	40	100	150	180	300
F_{max} (KN)	60	150	225	270	450
$\varnothing d_1$	125	175	175	210	300
$\varnothing d_2$ f8	70	100	100	130	200
$\varnothing d_3$	102	140	140	165	254
$\varnothing d_4$	M10	M16	M16	M20	M16
$\varnothing d_5$	33	46	62	68	78
$\varnothing d_6$ max	32	45	60.5	65	77
$\varnothing d_6$ not machined	18	19	26	30	35
$\varnothing d_x$ max	32	45	60.5	65	77
l_1	40	55	70	75	95
l_2	51	68	84	94	120
h_1	3	4	4	5	5
h_2	15	24	24	30	24
N	4	4	4	4	8
Mass (Kg)	2	8	8	15	28

Notes to couplings type B1/B2

- $\varnothing d_7$ = with standard keyway according to ISO 773
- $\varnothing d_x$ = The maximum accepted diameter described by the key

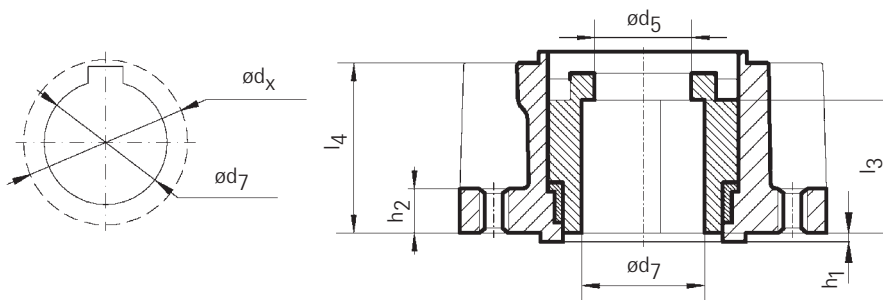

Model	010	020	030	040	050
ISO 5210	F10	F14	F14	F16	F25
$\varnothing d_5$	33	46	62	68	78
B1 $\varnothing d_7$ H9	42	60	60	80	100
B2 $\varnothing d_7$ max	42	60	60	80	100
$\varnothing d_x$ max	50	71	71	94	116
l_3	45	65	65	80	110
l_4	56	85	84	105	155
Mass (Kg)	2	7	7	14	26

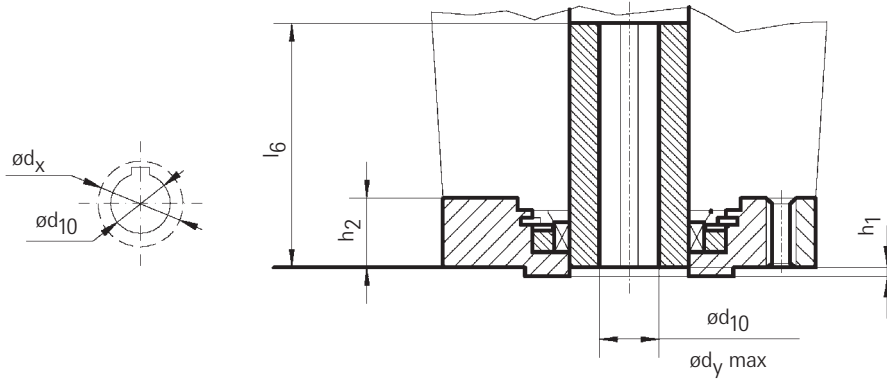

Notes to couplings type B3/B4

$\varnothing d_{10}$ = with standard keyway according to ISO 773

$\varnothing d_x$ = The maximum accepted diameter described by the key

Model	010	020	030	040	050
ISO 5210	F10	F14	F14	F16	F25
B3 $\varnothing d_{10}$ H9	20	30	30	40	50
B4 $\varnothing d_y$ max	22	32	46	50	58
$\varnothing d_x$	26	40	55	60	68
l_6	100	120	130	150	180
Mass (Kg)	1	6	6	12	20

General configuration

Default relay configuration (may be modified - see instruction manual)
 AS1 = Open limit/make
 AS2 = Close limit/make
 AS3 = Selec.REMOTE pos. make
 AS4 = Overtorque/break
 AS5 = Motor running/make
 AS6 = Position <10%/ make
 AS7 = ESD / make
 AS8 = Motor over temperature

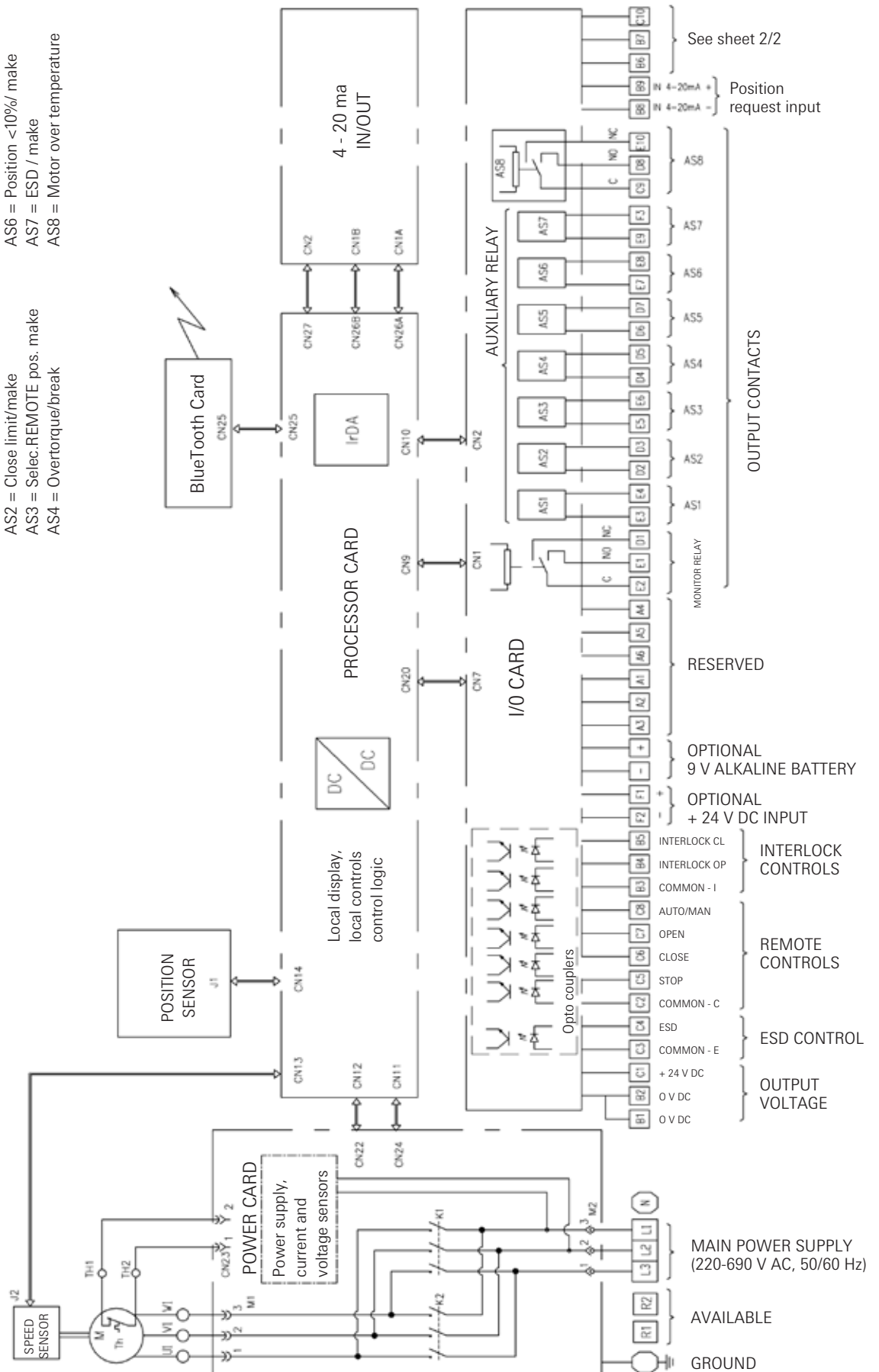

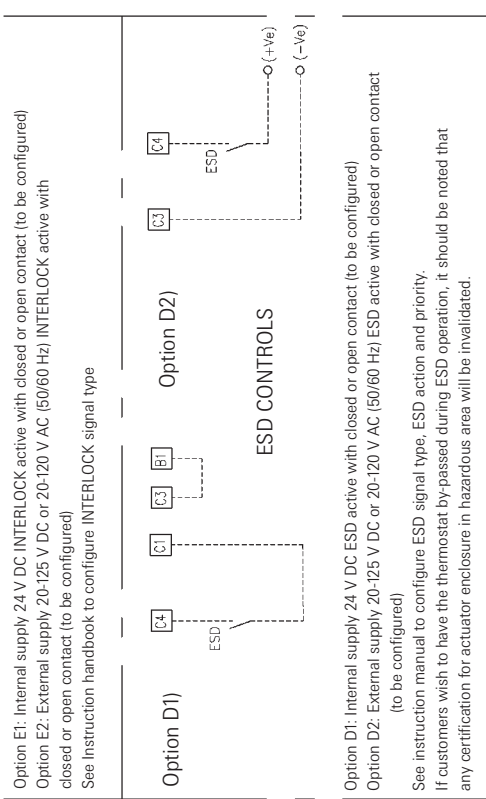
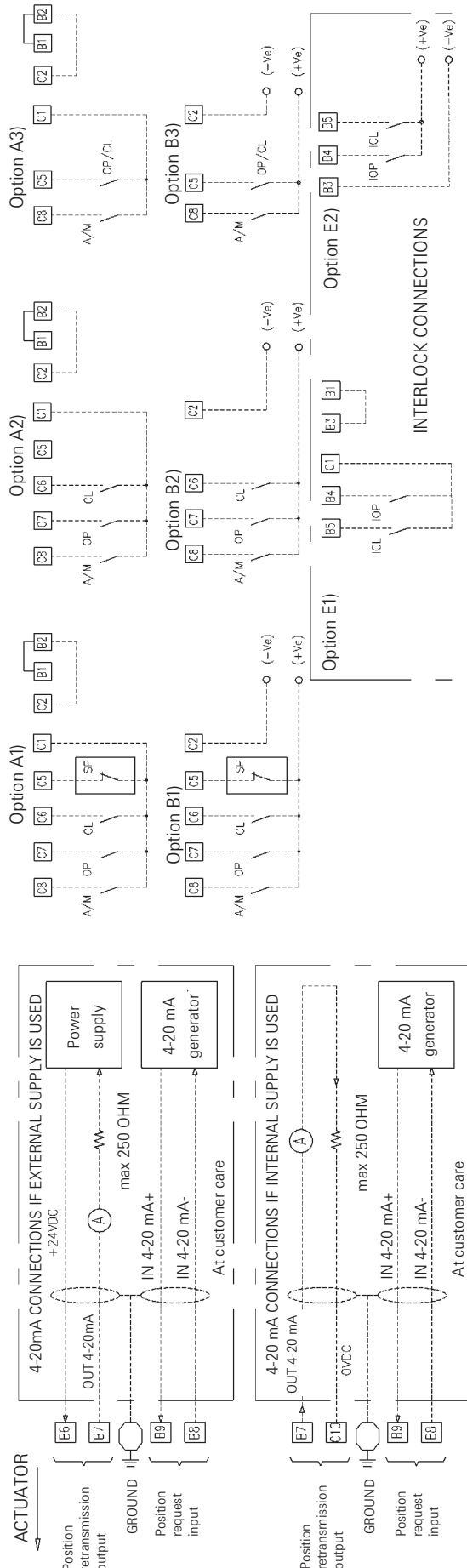

Option E1: Internal supply 24 V DC INTERLOCK active with closed or open contact (to be configured)
 Option E2: External supply 20-125 V DC or 20-120 V AC (50/60 Hz) INTERLOCK active with closed or open contact (to be configured)
 See Instruction handbook to configure INTERLOCK signal type

Option D1: Internal supply 24 V DC ESD active with closed or open contact (to be configured)
 Option D2: External supply 20-125 V DC or 20-120 V AC (50/60 Hz) ESD active with closed or open contact (to be configured)

See instruction manual to configure ESD signal type, ESD action and priority.
 If customers wish to have the thermostat by-passed during ESD operation, it should be noted that any certification for actuator enclosure in hazardous area will be invalidated.

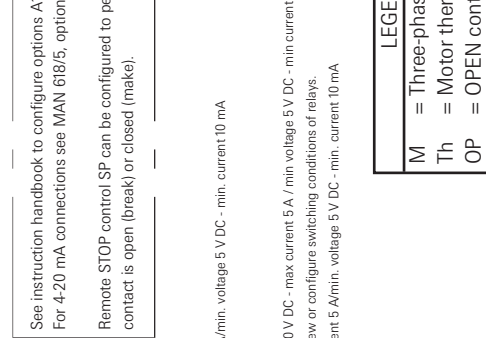

- Notes:**
- B1-B2 : Internally linked
 - C1 : +24 V DC not regulated, max 4W
 - Control signal levels: Minimum 'ON' >20 V DC or 2.0 V AC (50/60 Hz)
 Maximum 'ON' <125 V DC or 120 V AC (50/60 Hz)
 Maximum 'OFF' <3 V DC or AC
 Minimum signal duration > 500 ms
 Total current drawn for remote controls <25 mA
 Total current drawn for ESD controls <15 mA
 - Monitor relay:
 Voltage free, change-over contact-max voltage 250 V AC or 30 V DC - max current 5 A/min. voltage 5 V DC - min. current 10 mA
 See instruction manual to view or configure the switching conditions of relay
 -E2/D1 contact is closed when the configured condition occurs
 - AS1, AS2, AS3, AS4, AS5, AS6, AS7: Voltage-free contact. Max voltage 250 V AC or 30 V DC - max current 5 A / min voltage 5 V DC - min current 10 mA.
 Contact can be configured to make or break on condition. See instruction manual to view or configure switching conditions of relays.
 - AS8: Voltage free, change-over contact: max voltage 250 V AC or 30 V DC - max current 5 A/min. voltage 5 V DC - min. current 10 mA
 See instruction manual to view or configure the switching conditions of relay
 -C9/D8 contact is closed when the configured condition occurs
 - A1, A2, A3 : Internal supply 24 V DC
 - B1, B2, B3 : External supply 20-125 V DC or 20-120 V AC (50/60 Hz)
 - Controls mode :
 Option A1/B1 : 4 wires latched (SP configuration = BREAK)
 Option A2/B2 : 3 wires push to run
 : 3 wires latched with instant reverse
 : 2 wires open contact closes
 - A/M Open: Remote/Auto Actuator control by 4-20 mA input signal
 A/M Closed: Remote/Man Actuator control by remote push-buttons



For application on valves when a side-mounted multiturn actuator is requested. Penstocks are another typical application for this type of reducer.

BGR Multiturn Actuator Performances⁽⁴⁾

Model BGR ⁽¹⁾	Nom torque ⁽²⁾ (100%) (Nm)	Min torque (Nm)	Max torque ⁽³⁾ (Nm)	RPM ⁽⁵⁾ (50 Hz)	RPM ⁽⁵⁾ (60 Hz)	Motor type
BGR-3-010/360-**	360	144	540	5	6	SM12
BGR-3-010/360-**	360	144	540	8	10	SM13
BGR-3-010/360-**	360	144	540	11	13	SM14
BGR-3-010/360-**	360	144	540	16	19	SM15
BGR-3-010/360-**	360	144	540	32	38	SM16
BGR-7-020/720-**	720	288	1080	5	6	SM14
BGR-7-020/720-**	720	288	1080	8	10	SM15
BGR-7-020/720-**	720	288	1080	11	13	SM21
BGR-7-020/720-**	720	288	1080	16	19	SM22
BGR-7-020/720-**	720	288	1080	32	39	SM23
BGR-15-030/1440-**	1440	576	2160	5	6	SM21
BGR-15-030/1440-**	1440	576	2160	8	10	SM22
BGR-15-030/1440-**	1440	576	2160	11	13	SM30
BGR-15-030/1440-**	1440	576	2160	16	19	SM23
BGR-15-030/1440-**	1440	576	2160	32	39	SM31
BGR-30-040/2880-**	2880	1152	4320	5	6	SM30
BGR-30-040/2880-**	2880	1152	4320	8	10	SM40
BGR-30-040/2880-**	2880	1152	4320	11	13	SM41
BGR-30-040/2880-**	2880	1152	4320	16	19	SM31
BGR-30-040/2880-**	2880	1152	4320	32	38	SM42
BGR-60-050/5760-**	5760	2304	8640	5	6	SM41
BGR-60-050/5760-**	5760	2304	8640	8	10	SM31
BGR-60-050/5760-**	5760	2304	8640	11	13	SM50
BGR-60-050/5760-**	5760	2304	8640	16	19	SM42
BGR-60-050/5760-**	5760	2304	8640	32	38	SM51

See notes for Multiturn Actuator Performances

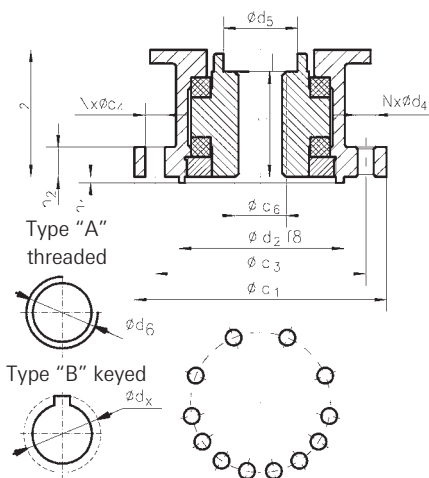

Notes to couplings type A

- Type 'A' = The block having the capability to transmit both a torque and a thrust.
- $\emptyset d_x$ = The max accepted diameter described by the key
- $l_1 \times 1.10$ = Minimum threaded valve stem protrusion
- F_{nom} = The max thrust applicable to the BGR block type 'A' in dynamic conditions with torque control set at 100%
- F_{max} = The max thrust applicable to the BGR block type 'A' in static conditions with manual override or with motor in stall torque

ICON2000 series BGR

Dimension	BGR 3	BGR 7	BGR 15	BGR 30	BGR 60
ISO 5210	F14	F16	F25	F30	F35
F_{nom} (KN)	150	180	300	440	700
F_{max} (KN)	225	270	450	660	1050
$\emptyset d_1$	175	210	300	350	415
$\emptyset d_2 f8$	100	130	200	230	260
$\emptyset d_3$	140	165	254	298	356
$\emptyset d_4$	M16	M20	M16	22	33
$\emptyset d_5$	62	68	78	78	97
$\emptyset d_6 \max (d_x)$	60.5	65	77	77	96
$\emptyset d_6 \min$	-	-	-	51	55
l_1	70	75	95	110	144
l_2	84	94	120	134	172
h_1	4	5	5	5	5
h_2	24	30	24	30	40
N	4	4	8	8	8
Mass (Kg)	8	15	28	48	75

For application on valves when a multiturn actuator is required and torque exceeds 1440 Nm.

The spur gear reducer and its thrust block are designed for the severest duties.

SGR Multiturn Actuator Performances⁽⁴⁾

Model SGR ⁽¹⁾	Nom torque ⁽²⁾ (100%) (Nm)	Min torque (Nm)	Max torque ⁽³⁾ (Nm)	RPM ⁽⁵⁾ (50 Hz)	RPM ⁽⁵⁾ (60 Hz)	Motor type
SGR-160-030/1750-**-**	1750	700	2625	26	31	SM31
SGR-160-030/2150-**-**	2150	860	3225	21	26	SM31
SGR-160-030/2880-**-**	2880	1152	4320	8	10	SM23
SGR-160-030/2880-**-**	2880	1152	4320	16	19	SM31
SGR-250-030/3600-**-**	3600	1440	5400	12	15	SM31
SGR-250-040/3600-**-**	3600	1440	5400	24	29	SM42
SGR-250-030/4800-**-**	4800	1920	7200	5	6	SM23
SGR-250-030/4800-**-**	4800	1920	7200	9	11	SM31
SGR-250-040/4800-**-**	4800	1920	7200	18	22	SM42
SGR-250-050/4800-**-**	4800	1920	7200	36	43	SM51
SGR-400-030/7500-**-**	7500	3000	11250	6	7	SM31
SGR-400-040/7500-**-**	7500	3000	11250	12	14	SM42
SGR-400-050/7500-**-**	7500	3000	11250	24	29	SM51
SGR-400-040/9600-**-**	9600	3840	14400	5	6	SM21
SGR-400-040/9600-**-**	9600	3840	14400	9	11	SM42
SGR-400-050/9600-**-**	9600	3840	14400	18	22	SM51
SGR-640-050/9600-**-**	9600	3840	14400	18	22	SM51
SGR-640-040/15000-**-**	15000	6000	22500	6	7	SM42
SGR-640-050/16000-**-**	16000	6400	24000	11	13	SM51
SGR-640-050/19200-**-**	19200	7680	28800	5	6	SM42
SGR-640-050/19200-**-**	19200	7680	28800	9	11	SM51
SGR-1000-050/22000-**-**	22000	8800	33000	8	9	SM51
SGR-1000-050/28000-**-**	28000	11200	42000	6	7	SM51
SGR-1000-050/37000-**-**	37000	14800	55500	2	3	SM42
SGR-1000-050/37000-**-**	37000	14800	55500	5	6	SM51
SGR-1600-050/40000-**-**	40000	16000	60000	4	5	SM51
SGR-1600-050/48000-**-**	48000	19200	72000	3	4	SM51
SGR-1600-050/57000-**-**	57000	22800	85500	3	4	SM51

See notes for Multiturn Actuator Performances

ICON2000 series SGR

Dimension	SGR 160	SGR 250	SGR 400	SGR 640	SGR 1000	SGR 1600
ISO 5210	F30	F35	F35	---	---	---
F _{nom} (KN)	440	700	1200	2250	3200	4500
F _{max} (KN)	660	1050	1800	3375	4800	6750
Ø d ₁	350	415	415	475	500	620
Ø d ₂ f8	230	260	260	300	330	400
Ø d ₃	298	356	356	406	425	520
Ø d ₄	22	33	33	39	M36	M45
Ø d ₅	78	97	109	130	156	188
Ø d ₆ max (d _x)	77	96	108	127	153	180
Ø d ₆ min	51	55	60	75	90	95
l ₁	110	144	178	216	252	307
l ₂	134	172	201	250	290	354
h ₁	5	5	5	8	8	8
h ₂	30	40	45	45	50	58
N	8	8	8	16	16	16
Mass (Kg)	48	75	105	150	195	250

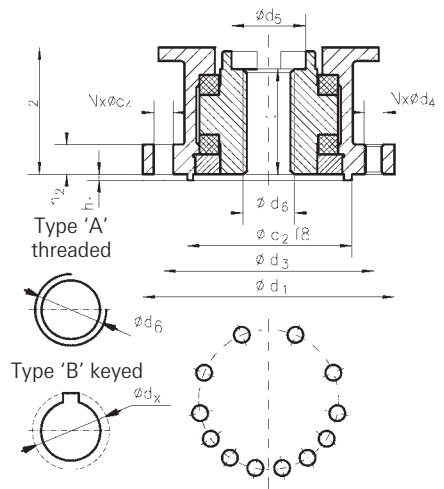

Notes to couplings type A

- Type 'A' = The block having the capability to transmit both a torque and a thrust.
- Ø d_x = The max accepted diameter described by the key
- l₁ x1.10 = Minimum threaded valve stem protrusion
- F_{nom} = The max thrust applicable to the SGR block type 'A' in dynamic conditions with torque control set at 100%
- F_{max} = The max thrust applicable to the SGR block type 'A' in static conditions with manual override or with motor in stall torque

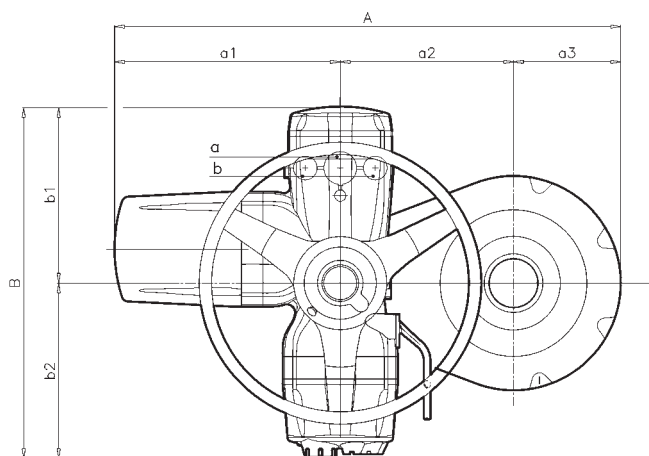
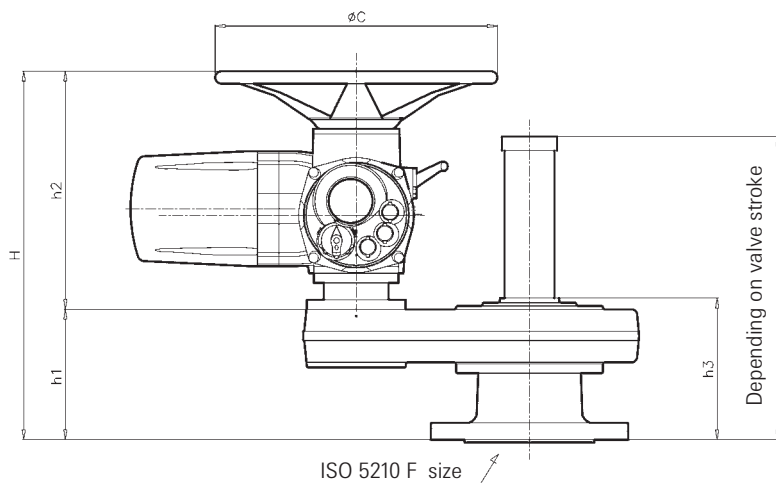

Standard cable entries:
 a = 1" NPT
 b = 1 1/2" NPT

SGR/ICON2000 series overall dimensions

Model	A	a ₁	a ₂	a ₃	B	b ₁	b ₂	ØC	F	H	h ₁	h ₂	h ₃	Mass Kg
SGR-160-030	859	399	270	190	625	313	312	400	F30	617	231	380	251	127
SGR-250-030	927	399	319	227	625	313	312	500	F35	684	315	380	345	154
SGR-250-040	983	445	319	227	690	318	372	500	F35	724	280	420	310	170
SGR-250-050	1036	508	319	227	775	363	392	500	F35	684	280	380	310	194
SGR-400-030	980	399	373	208	625	313	312	500	F35	736	356	380	383	232
SGR-400-040	1036	455	373	208	690	318	372	500	F35	776	356	420	383	248
SGR-400-050	1089	508	373	208	775	363	392	500	F35	866	356	510	383	272
SGR-640-040	1098	455	405	237	690	318	372	600	SPEC.	838	418	420	460	288
SGR-640-050	1151	508	405	238	755	363	392	600	SPEC.	928	418	510	460	312
SGR-1000-050	1264	508	456	300	755	363	392	600	SPEC.	968	458	510	500	417
SGR-1600-050	1560	508	602	450	755	363	392	600	SPEC.	1040	522	510	564	752

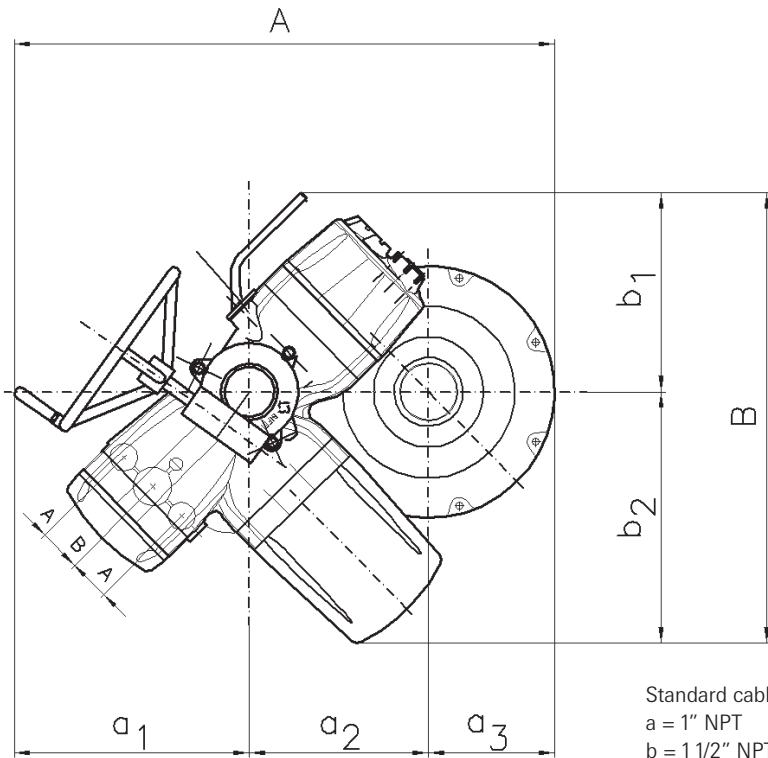
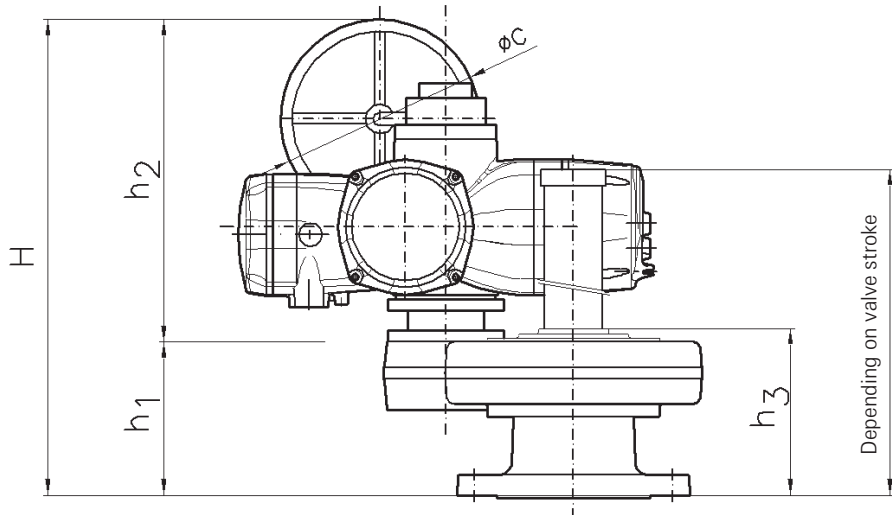

Standard cable entries:
 a = 1" NPT
 b = 1 1/2" NPT

SGR/ICON2000 Series Overall Dimensions (with reduced manual override)

Model	A	a ₁	a ₂	a ₃	B	b ₁	b ₂	ØC	H	h ₁	h ₂	h ₃	Mass
													Kg
SGR-160-030	814	354	270	190	679	300	379	300	717	231	486	251	135
SGR-250-030	880	354	319	227	678	302	376	300	748	315	448	345	162
SGR-250-040	942	416	319	227	742	310	432	400	828	280	528	310	178
SGR-250-050	1012	484	319	227	809	334	475	500	977	280	677	310	202
SGR-400-030	934	354	373	208	678	302	376	300	817	356	461	383	240
SGR-400-040	995	415	373	208	741	311	430	400	884	356	528	383	256
SGR-400-050	1064	484	373	208	809	334	475	500	1033	356	677	383	280
SGR-640-040	1057	415	405	238	743	311	432	400	947	418	528	460	296
SGR-640-050	1124	482	405	238	807	335	472	500	1091	418	673	460	320
SGR-1000-050	1240	484	456	300	809	334	475	500	1132	458	674	500	425
SGR-1600-050	1535	483	602	450	808	334	474	500	1196	522	674	564	760

ICON 2000 - Electric Actuators

Worm gear reducers for quarter turn valves



For application on any type of quarter turn valves (ball, butterfly, plug...).
The worm gear is designed to meet AWWA C-540 and other major standards.

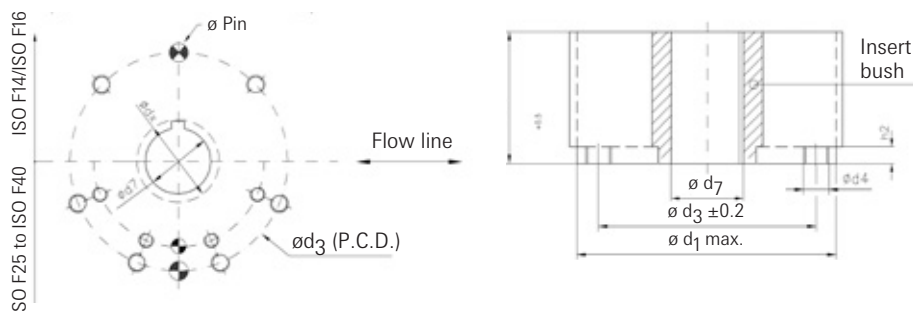

Notes

1. Insert bush supplied by Biffi with unmachined bore. Machining of bore upon request
2. Fixing bolts or rods supplied by Biffi only on request, minimum material class required 8.8 UNI37409, ASTM A320-L7
3. Any other coupling can be supplied on request
4. Flanges for models WGR-800, 1600 and 3200 have double PCD.

ICON2000 series WGR

Model	ISO 5211	Ø d ₁	Ø d ₃	Ø d ₄	N°	H	h ₂	Ø Pin	d ₇ max stem acceptance insert bush	Ø d _x
WGR-100	F14	175	140	M16	4	100	16	16	42	51
WGR-200	F16	210	165	M20	4	105	20	16	65	76
WGR-400	F16	210	165	M20	4	105	20	16	65	76
WGR-800	F25	300	254	M16	8	115	20	20	90	104
WGR-800	F30	350	298	M20	8	115	20	20	90	104
WGR-1600	F25	300	254	M16	8	140	24	20	103	120
WGR-1600	F30	350	298	M20	8	140	30	20	103	120
WGR-3200	F30	350	298	M20	8	165	30	20	120	139
WGR-3200	F35	415	356	M30	8	165	30	20	120	139
WGR-6300	F40	475	406	M36	8	250	35	30	170	194

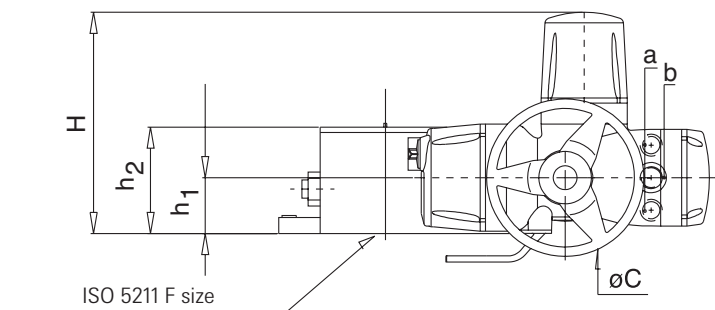

Standard cable entries:

- a = 1" NPT
- b = 1 1/2" NPT

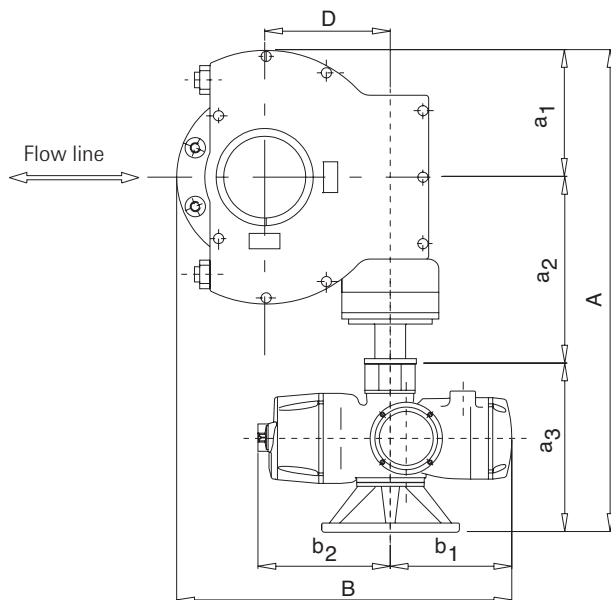

WGR/ICON2000 series overall dimensions

Model	A	a ₁	a ₂	a ₃	B	b ₁	b ₂	ØC	D	F	H	h ₁	h ₂	Mass Kg
WGR-100-010	519	90	139	290	421	273	292	300	86	F14	367	62	115	40
WGR-200-010	560	123	147	290	466	273	292	300	119	F16	381	53	125	52
WGR-400-010	662	123	269	270	491	273	292	500	119	F16	390	53	125	69
WGR-800-020	820	150	302	368	562	283	300	500	130	F25	397	60	135	85
WGR-1600-020	871	160	343	368	594	283	300	500	162	F25/F30	412	75	165	130
WGR-3200-020	943	250	325	368	700	283	300	500	243	F30/F35	427	90	180	166
WGR-3200-030	989	250	325	414	743	313	312	600	243	F30/F35	453	90	180	174
WGR-6300-020	1053	305	380	368	820	283	300	500	303	F40	472	135	270	509
WGR-6300-030	1099	305	380	414	844	313	312	600	303	F40	498	135	270	517
WGR-6300-040	1163	305	380	478	886	318	372	720	303	F40	596	135	270	527

WGR-Quarter turn Actuator Performances with 3-ph motors⁽⁴⁾

Model WGR⁽¹⁾	Nom torque⁽²⁾(100%) (Nm)	Min torque (Nm)	Max torque⁽³⁾ (Nm)	Op. time/90° (secs at 50 Hz)	Op. time/90° (secs at 60 Hz)	Motor type
WGR-110/330-**	330	132	500	63	52	SM00
WGR-110/330-**	330	132	500	42	35	SM01
WGR-110/330-**	330	132	500	31	26	SM10
WGR-110/330-**	330	132	500	21	17	SM11
WGR-110/330-**	330	132	500	16	13	SM04
WGR-110/330-**	330	132	500	10	9	SM05
WGR-100-010/1000-**	1000	400	1500	63	52	SM10
WGR-100-010/1000-**	1000	400	1500	42	35	SM11
WGR-100-010/1000-**	1000	400	1500	31	26	SM12
WGR-100-010/1000-**	1000	400	1500	21	17	SM13
WGR-100-010/1000-**	1000	400	1500	16	13	SM14
WGR-100-010/1000-**	1000	400	1500	10	9	SM15
WGR-200-010/2000-**	2000	800	3000	125	104	SM10
WGR-200-010/2000-**	2000	800	3000	83	69	SM11
WGR-200-010/2000-**	2000	800	3000	63	52	SM12
WGR-200-010/2000-**	2000	800	3000	42	35	SM13
WGR-200-010/2000-**	2000	800	3000	31	26	SM14
WGR-200-010/2000-**	2000	800	3000	21	17	SM15
WGR-200-010/2000-**	2000	800	3000	10	9	SM16
WGR-400-010/4000-**	4000	1600	6000	155	118	SM10
WGR-400-010/4000-**	4000	1600	6000	103	78	SM11
WGR-400-010/4000-**	4000	1600	6000	78	59	SM12
WGR-400-010/4000-**	4000	1600	6000	52	39	SM13
WGR-400-010/4000-**	4000	1600	6000	39	29	SM14
WGR-400-010/4000-**	4000	1600	6000	26	20	SM15
WGR-400-010/4000-**	4000	1600	6000	13	10	SM16
WGR-800-020/8000-**	8000	3200	12000	250	208	SM12
WGR-800-020/8000-**	8000	3200	12000	167	139	SM13
WGR-800-020/8000-**	8000	3200	12000	125	104	SM14
WGR-800-020/8000-**	8000	3200	12000	83	69	SM15
WGR-800-020/8000-**	8000	3200	12000	63	52	SM21
WGR-800-020/8000-**	8000	3200	12000	42	35	SM22
WGR-800-020/8000-**	8000	3200	12000	21	17	SM23
WGR-1600-020/16000-**	16000	6400	24000	466	389	SM12
WGR-1600-020/16000-**	16000	6400	24000	311	259	SM13
WGR-1600-020/16000-**	16000	6400	24000	233	194	SM14
WGR-1600-020/16000-**	16000	6400	24000	155	130	SM15
WGR-1600-020/16000-**	16000	6400	24000	117	97	SM21
WGR-1600-020/16000-**	16000	6400	24000	78	65	SM22
WGR-1600-020/16000-**	16000	6400	24000	39	32	SM23
WGR-3200-020/32000-**	32000	12800	48000	623	519	SM13
WGR-3200-020/32000-**	32000	12800	48000	467	389	SM14
WGR-3200-020/32000-**	32000	12800	48000	311	259	SM15
WGR-3200-020/32000-**	32000	12800	48000	233	195	SM21
WGR-3200-020/32000-**	32000	12800	48000	156	130	SM22
WGR-3200-020/32000-**	32000	12800	48000	78	65	SM23
WGR-3200-030/32000-**	32000	12800	48000	42	35	SM31
WGR-6300-020/63000-**	63000	25200	94500	700	583	SM15
WGR-6300-020/63000-**	63000	25200	94500	525	438	SM21
WGR-6300-020/63000-**	63000	25200	94500	350	292	SM22
WGR-6300-020/63000-**	63000	25200	94500	175	146	SM23
WGR-6300-030/63000-**	63000	25200	94500	96	80	SM31
WGR-6300-040/63000-**	63000	25200	94500	48	40	SM42

See notes for Multiturn Actuator performances



Scotch-yoke reducer for application on valves requiring high torques at stroke limits (Open/Close). Also used on quarter-turn valves when very high torques are required.

Notes

1. The ** are to be replaced by operating time value at selected frequency (50 or 60 Hz)
2. Nominal output torque settable from 40% (minimum torque) to 100% of indicated value
3. Theoretic max output torque. The actual max output torque is a function of speed and motor power supply and may vary from 1.3 to 2 times nominal output torque
4. The above performances are referred to ON/OFF S2-15' or INCHING S4-25%-60 starts/hour duties (IEC34-1)

ELGA Actuator Performances with 3-phase motors⁽⁴⁾

Model ⁽¹⁾	Nom. torque ⁽²⁾ (100%) (Nm)			Max torque ⁽³⁾ (Nm)	Op. time /90° (50 Hz)	Op. time /90° (60 Hz)	ICON2000 model	Motor type	Motor power (KW) at 50 Hz	Motor power (KW) at 60 Hz
	Break to open	Running	End to open							
ELGA-14KR-020/94000-**-	94000	54300	82000	141000	865	721	ICON-020/180-24(29)	SM14	0.286	0.343
ELGA-14KR-020/94000-**-	94000	54300	82000	141000	577	481	ICON-020/180-36(43)	SM15	0.367	0.440
ELGA-14KR-020/94000-**-	94000	54300	82000	141000	433	361	ICON-020/180-48(58)	SM21	0.526	0.631
ELGA-14KR-020/94000-**-	94000	54300	82000	141000	288	240	ICON-020/180-72(86)	SM22	0.789	0.947
ELGA-14KR-020/94000-**-	94000	54300	82000	141000	144	120	ICON-020/180-144(173)	SM23	1.470	1.764
ELGA-14KR-030/94000-**-	94000	54300	82000	141000	69	58	ICON-030/360-144(173)	SM31	3.368	4.042
ELGA-14KR-040/94000-**-	94000	54300	82000	141000	42	35	ICON-040/720-144(173)	SM42	5.818	6.982
ELGA-18KR-020/133000-**-	133000	77000	116000	199500	1330	1108	ICON-020/180-24(29)	SM14	0.286	0.343
ELGA-18KR-020/133000-**-	133000	77000	116000	199500	887	739	ICON-020/180-36(43)	SM15	0.367	0.440
ELGA-18KR-020/133000-**-	133000	77000	116000	199500	665	554	ICON-020/180-48(58)	SM21	0.526	0.631
ELGA-18KR-020/133000-**-	133000	77000	116000	199500	443	369	ICON-020/180-72(86)	SM22	0.789	0.947
ELGA-18KR-020/133000-**-	133000	77000	116000	199500	222	185	ICON-020/180-144(173)	SM23	1.470	1.764
ELGA-18KR-030/133000-**-	133000	77000	116000	199500	133	111	ICON-030/360-144(173)	SM31	3.368	4.042
ELGA-18KR-040/133000-**-	133000	77000	116000	199500	57	48	ICON-040/720-144(173)	SM42	5.818	6.982
ELGA-32KR-030/266000-**-	266000	156000	238000	399000	1272	1060	ICON-030/360-36(43)	SM22	0.789	0.947
ELGA-32KR-030/266000-**-	266000	156000	238000	399000	954	795	ICON-030/360-48(58)	SM30	1.123	1.348
ELGA-32KR-030/266000-**-	266000	156000	238000	399000	636	530	ICON-030/360-72(86)	SM23	1.470	1.764
ELGA-32KR-030/266000-**-	266000	156000	238000	399000	318	265	ICON-030/360-144(173)	SM31	3.368	4.042
ELGA-32KR-040/266000-**-	266000	156000	238000	399000	181	151	ICON-040/720-144(173)	SM42	5.818	6.982
ELGA-32KR-050/266000-**-	266000	156000	238000	399000	75	63	ICON-050/1440-144(173)	SM51	11.636	13.963
ELGA-50KR-030/334000-**-	334000	197000	300000	501000	1280	1067	ICON-030/360-36(43)	SM22	0.789	0.947
ELGA-50KR-030/334000-**-	334000	197000	300000	501000	960	800	ICON-030/360-48(58)	SM30	1.123	1.348
ELGA-50KR-030/334000-**-	334000	197000	300000	501000	640	533	ICON-030/360-72(86)	SM23	1.470	1.764
ELGA-50KR-030/334000-**-	334000	197000	300000	501000	320	267	ICON-030/360-144(173)	SM31	3.368	4.042
ELGA-50KR-040/334000-**-	334000	197000	300000	501000	152	127	ICON-040/720-144(173)	SM42	5.818	6.982
ELGA-50KR-050/334000-**-	334000	197000	300000	501000	65	54	ICON-050/1440-144(173)	SM51	11.636	13.963

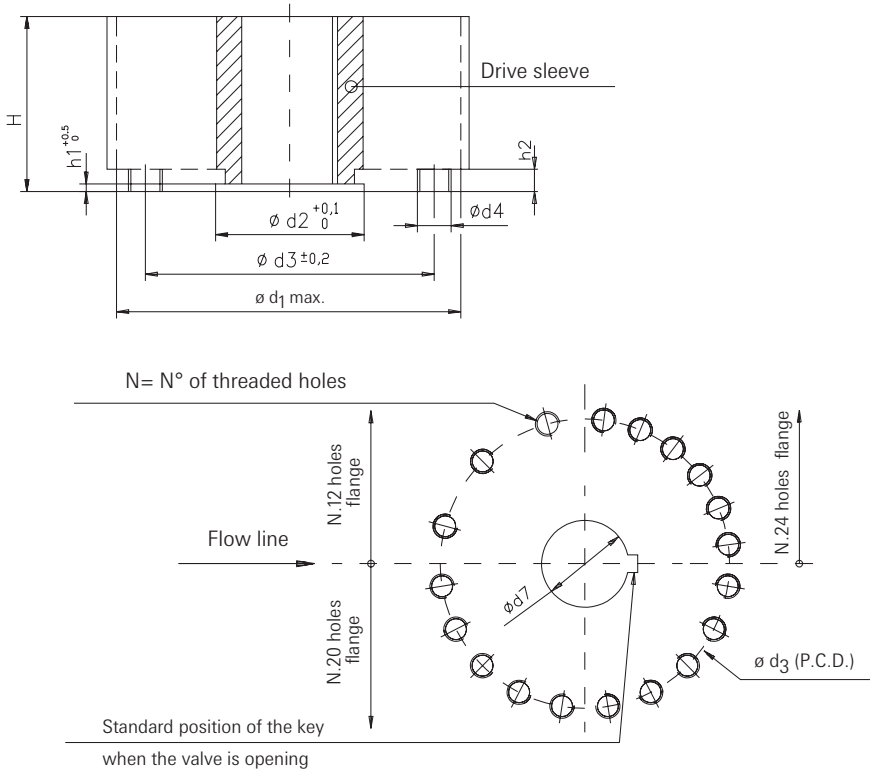

Notes

1. Drive sleeve supplied by Biffi with unmachined bore. Machining of bore upon request
2. Different values of flange dimensions can be supplied on request
3. Keyway for rectangular key, according to DIN 6885 SH.1 or BS 4235 or UNI 6604 or equivalent
4. Keyway for square key according to ANSI B17.1-1967 or equivalent
5. Female spigot supplied as a standard. Male spigot supplied on request
6. Fixing bolts or rods supplied by Biffi only on request, minimum material class required 8.8 UNI37409, ASTM A320-L7

ICON2000 series Elga

Dimension	Elga 14	Elga 18	Elga 32	Elga 50
ISO 5211 ⁽²⁾	F48	F60	F60	SPECIAL
Ø d ₁	580	680	780	800
Ø d ₂ ⁽⁵⁾	250	290	290	315
Ø d ₃	483	603	603	698
Ø d ₄ ⁽⁶⁾	M36	M36	M36	M36
h ₁ ⁽⁵⁾	10	12	12	10
h ₂	29	32	32	32
N	12	20	20	24
H	340	350	400	430
d ₇ MAX STEM ACCEPT. Rectangular key UNI/DIN ⁽³⁾	Ø200	Ø220	Ø230	Ø255
d ₇ MAX STEM ACCEPT. Square key ⁽⁴⁾	Ø175	Ø190	Ø200	Ø225
d ₇ MAX STEM ACCEPT. Square stem.	150	170	175	190

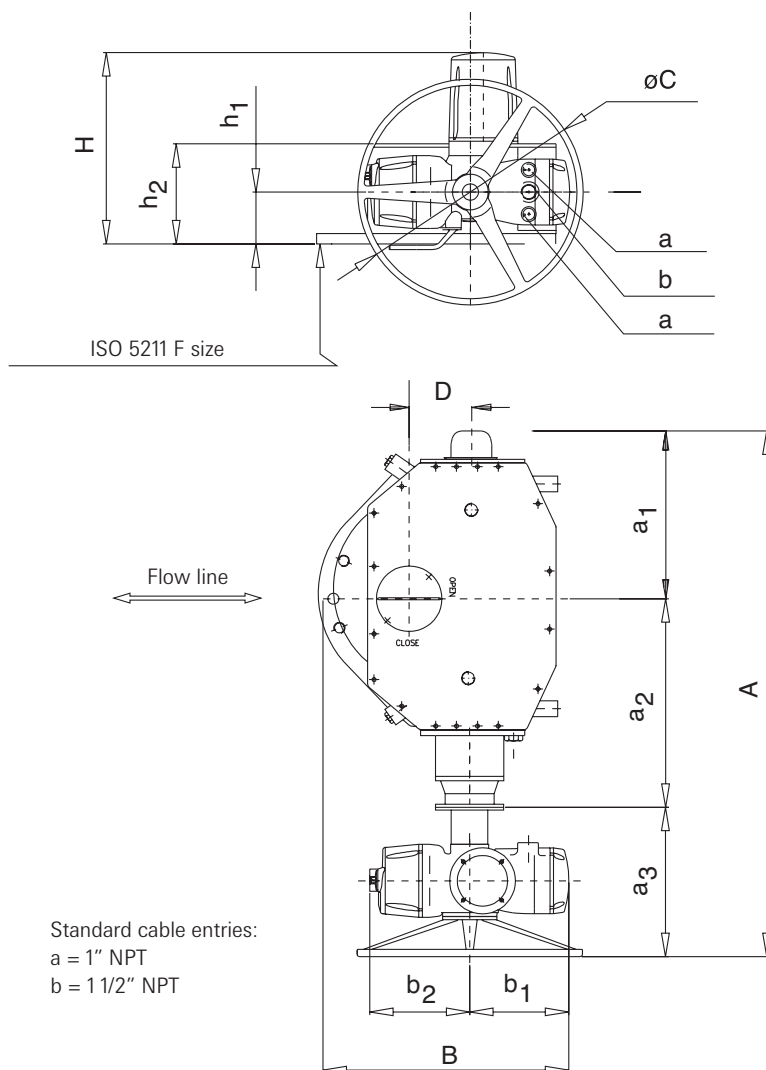

ELGA/ICON2000 series overall dimensions

Model	A	a ₁	a ₂	a ₃	B	b ₁	b ₂	ØC	D	F	H	h ₁	h ₂	Mass Kg
14KR-020	1619	536	778	305	772	283	300	500	200	F48	463	166	320	650
14KR-030	1653	536	778	339	793	313	312	600	200	F48	476	166	320	660
14KR-040	1712	536	778	398	835	318	372	720	200	F48	627	166	320	670
18KR-020	1727	583	839	305	852	283	300	500	230	F60	542	195	383	800
18KR-030	1761	583	839	339	873	313	312	600	230	F60	595	195	383	810
18KR-040	1820	583	839	398	915	318	372	720	230	F60	656	195	383	820
32KR-030	1.964	663	1.124	339	863	313	312	600	270	F60	632	232	464	960
32KR-040	2.064	663	1.164	398	1005	318	372	720	270	F60	693	232	464	970
32KR-050	2.185	663	1.244	478	1049	363	392	860	270	F60	750	232	464	980
50KR-030	2.340	710	1.291	339	1003	313	312	600	300	SPEC.	633	233	561	1180
50KR-040	2.439	710	1.331	398	1045	318	372	720	300	SPEC.	694	233	561	1190
50KR-050	2.599	710	1.411	478	1089	363	392	860	300	SPEC.	751	233	561	2000



For specific application on linear valves (gate, globe...) with non-threaded stem, generally to replace piston or diaphragm pneumatic actuators.

Notes

1. The ** are to be replaced by Linear speed value at selected frequency (50 or 60 Hz)
2. Nominal output thrust settable from 40% (minimum thrust) to 100% of indicated value
3. Theoretic max output thrust. The actual max output thrust is a function of speed and motor power supply and may vary from 1.4 to 2 times nominal output thrust
4. The above performances are referred to ON/OFF S2-15' or INCHING S4-25%-60 starts/hour duties (IEC34-1)
5. Referred to Running thrust = 40% Nominal thrust

ICON2000L Linear Actuator Performances with 3-phase motors⁽⁴⁾

Model ⁽¹⁾	Nominal thrust ⁽²⁾ (100%) (KN)	Min thrust (KN)	Max thrust ⁽³⁾ (KN)	Linear speed ⁽⁵⁾ (mm/secs at 50 Hz)	Linear speed ⁽⁵⁾ (mm/secs at 60 Hz)	Motor type	Mot. power (KW) at 50 Hz	Mot. power (KW) at 60 Hz	R
ICON-010L/10-**	10	4	15	0.6	0.7	SM00	0.030	0.036	40:1
ICON-010L/10-**	10	4	15	0.9	1.1	SM01	0.046	0.055	40:1
ICON-010L/10-**	10	4	15	1.2	1.4	SM10	0.071	0.085	20:1
ICON-010L/10-**	10	4	15	1.4	1.7	SM11	0.106	0.127	20:1
ICON-010L/10-**	10	4	15	2.2	2.6	SM04	0.142	0.170	20:1
ICON-010L/10-**	10	4	15	3.6	4.3	SM05	0.213	0.256	20:1
ICON-010L/40-**	40	16	60	0.6	0.7	SM10	0.071	0.085	40:1
ICON-010L/40-**	40	16	60	0.9	1.1	SM11	0.106	0.127	40:1
ICON-010L/40-**	40	16	60	1.2	1.4	SM12	0.122	0.146	20:1
ICON-010L/40-**	40	16	60	1.4	1.7	SM13	0.184	0.221	20:1
ICON-010L/40-**	40	16	60	2.2	2.6	SM14	0.286	0.343	20:1
ICON-010L/40-**	40	16	60	3.6	4.3	SM15	0.367	0.440	20:1
ICON-020L/60-**	60	24	90	0.8	1.0	SM12	0.122	0.146	40:1
ICON-020L/60-**	60	24	90	1.2	1.4	SM13	0.184	0.221	40:1
ICON-020L/60-**	60	24	90	1.6	1.9	SM14	0.286	0.343	40:1
ICON-020L/60-**	60	24	90	2.4	2.9	SM15	0.367	0.440	40:1
ICON-020L/60-**	60	24	90	3.2	3.8	SM21	0.526	0.631	20:1
ICON-020L/60-**	60	24	90	4.8	5.8	SM22	0.789	0.947	20:1
ICON-030L/90-**	90	36	135	1.0	1.2	SM21	0.526	0.631	80:1
ICON-030L/90-**	90	36	135	1.5	1.8	SM32	0.500	0.600	40:1
ICON-030L/90-**	90	36	135	2.0	2.4	SM21	0.526	0.631	40:1
ICON-030L/90-**	90	36	135	3.0	3.6	SM22	0.789	0.947	40:1
ICON-030L/90-**	90	36	135	4.0	4.8	SM30	1.123	1.348	20:1
ICON-030L/90-**	90	36	135	6.0	7.2	SM23	1.470	1.764	40:1
ICON-040L/150-**	150	60	225	1.6	1.9	SM30	1.123	1.348	80:1
ICON-040L/150-**	150	60	225	2.4	2.9	SM44	0.840	1.008	40:1
ICON-040L/150-**	150	60	225	3.2	3.8	SM30	1.123	1.348	40:1
ICON-040L/150-**	150	60	225	4.8	5.8	SM40	1.684	2.021	40:1
ICON-040L/150-**	150	60	225	6.4	7.7	SM41	1.939	2.327	20:1
ICON-040L/150-**	150	60	225	9.6	11.5	SM31	3.368	4.042	40:1

Notes

1. The stem is drawn in fully retracted position.
 2. The stem end ($\varnothing d_8$) is left hand thread
 3. Only axial loads are permitted
 4. F_{nom} = the maximum thrust applicable to the linear thrust block in dynamic conditions with torque control set at 100%.
- F_{max} = the maximum thrust applicable to the linear thrust block in static conditions with manual override or with motor in stall torque

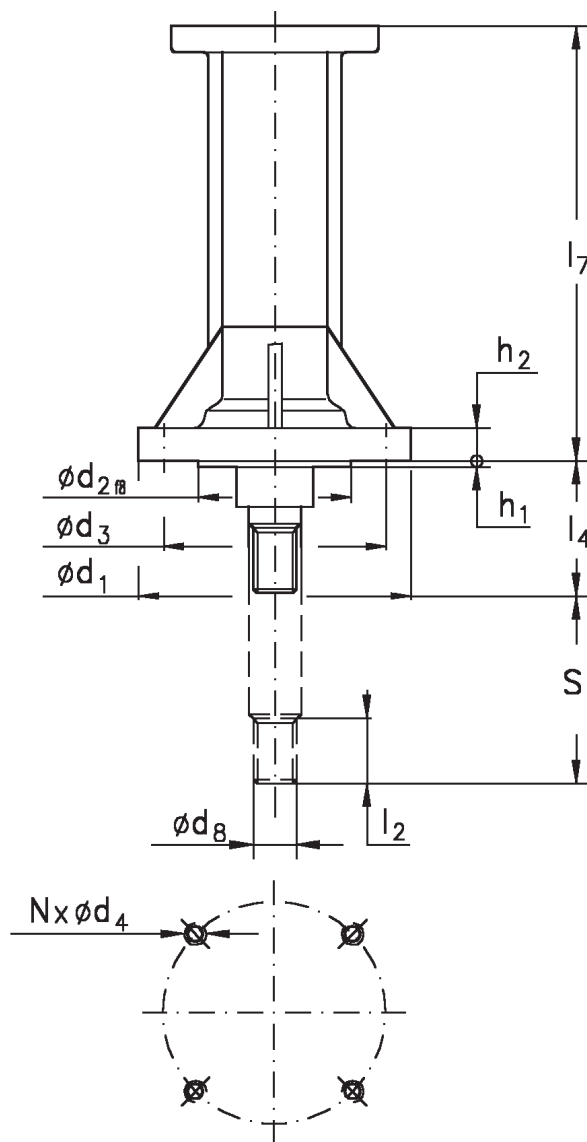

ICON2000 series Linear

Model	010L	020L	030L	040L
ISO 5210/DIN3358	F10	F14	F14	F16
F_{nom} (KN)	40	60	80	150
F_{max} (KN)	60	90	135	225
$\varnothing d_1$	125	175	175	210
$\varnothing d_2 f_8$	70	100	100	130
$\varnothing d_3$	102	140	140	165
$\varnothing d_4$	M10	M16	M16	M20
$\varnothing d_8$ (left)	M20x1,5	M36x3	M36x3	M42x3
h_1	3	4	4	4
h_2	15	24	24	30
l_7	265	375	480	580
l_2	25	55	55	65
l_4	35	60	60	80
N	4	4	4	4
S (Max stroke)	100	160	200	300
Mass (Kg)	10	18	22	28

ICON2000L Linear Actuator Performances with 3-phase motors⁽⁴⁾

Model ⁽¹⁾	Nominal thrust ⁽²⁾ (100%) (KN)	Min thrust (KN)	Max thrust ⁽³⁾ (KN)	Linear speed ⁽⁵⁾	Linear speed ⁽⁵⁾	Motor type	Mot. power	Mot. power	R
				(mm/secs at 50 Hz)	(mm/secs at 60 Hz)		(KW) at 50 Hz	(KW) at 60 Hz	
ICON-010L/10-**	10	4	15	0.6	0.7	TM00	0.030	0.036	40:1
ICON-010L/10-**	10	4	15	0.9	1.1	TM01	0.046	0.055	40:1
ICON-010L/10-**	10	4	15	1.2	1.4	TM10	0.071	0.085	20:1
ICON-010L/10-**	10	4	15	1.4	1.7	TM11	0.106	0.127	20:1
ICON-010L/10-**	10	4	15	2.2	2.6	TM04	0.142	0.170	20:1
ICON-010L/10-**	10	4	15	3.6	4.3	TM05	0.213	0.256	20:1
ICON-010L/40-**	40	16	60	0.6	0.7	TM10	0.071	0.085	40:1
ICON-010L/40-**	40	16	60	0.9	1.1	TM11	0.106	0.127	40:1
ICON-010L/40-**	40	16	60	1.2	1.4	TM12	0.122	0.146	20:1
ICON-010L/40-**	40	16	60	1.4	1.7	TM13	0.184	0.221	20:1
ICON-010L/40-**	40	16	60	2.2	2.6	TM14	0.286	0.343	20:1
ICON-010L/40-**	40	16	60	3.6	4.3	TM15	0.367	0.440	20:1
ICON-020L/60-**	60	24	90	0.8	1.0	TM12	0.122	0.146	40:1
ICON-020L/60-**	60	24	90	1.2	1.4	TM13	0.184	0.221	40:1
ICON-020L/60-**	60	24	90	1.6	1.9	TM14	0.286	0.343	40:1
ICON-020L/60-**	60	24	90	2.4	2.9	TM15	0.367	0.440	40:1
ICON-020L/60-**	60	24	90	3.2	3.8	TM21	0.526	0.631	20:1
ICON-020L/60-**	60	24	90	4.8	5.8	TM22	0.789	0.947	20:1
ICON-030L/90-**	90	36	135	2.0	2.4	TM21	0.526	0.631	40:1
ICON-030L/90-**	90	36	135	3.0	3.6	TM22	0.789	0.947	40:1
ICON-030L/90-**	90	36	135	4.0	4.8	TM30	1.123	1.348	20:1
ICON-030L/90-**	90	36	135	6.0	7.2	TM23	1.470	1.764	40:1
ICON-040L/150-**	150	60	225	3.2	3.8	TM30	1.123	1.348	40:1
ICON-040L/150-**	150	60	225	4.8	5.8	TM40	1.684	2.021	40:1
ICON-040L/150-**	150	60	225	9.6	11.5	TM31	3.368	4.042	40:1

Notes

1. The ** are to be replaced by Linear speed value at selected frequency (50 or 60 Hz)
2. Nominal output thrust settable from 40% (minimum thrust) to 100% of indicated value
3. Theoretic max output thrust. The actual max output thrust is a function of speed and motor power supply and may vary from 1.3 to 2 times nominal output thrust
4. The above performances are referred to ON/OFF S2-30' or INCHING S4-25%-600 starts/hour duties (IEC34-1)
5. Referred to Running thrust = 40% Nominal thrust